

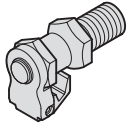







Lifting and Clamping Devices

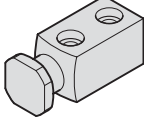

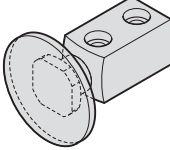
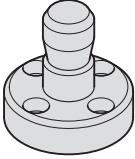
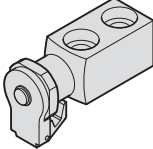
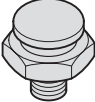
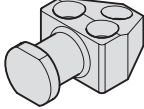
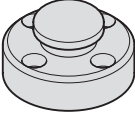
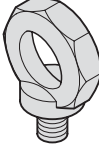
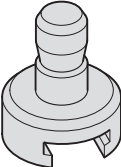
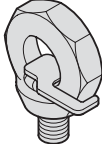
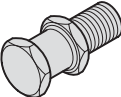



Contents

	211.11. Die set shank, straight	C10		2130.03. Screw-in lifter stud with cable securing device	C14
	211.12. Threaded die set shank DIN ISO 10242-1	C10		2130.11. Lifter stud VDI 3366	C15
	211.13. Die set shank with collar	C11		2130.12. Lifter stud with cable securing device, with welded disc	C15
	211.14. Bolt-on die set shank, ~DIN ISO 10242-2	C11		2130.13. Lifter stud with cable securing device	C16
	212.11. Coupling spigot with thread	C12		213.13. Lifter stud	C17
	212.15. Coupling spigot with flange	C12		2131.10. Lifting eye bolt, high tensile	C18
	212.16. Spigot holder	C13		2131.11. Lifting eye bolt, rotatable	C19
	213.12. Screw-in lifter stud VDI 3366	C13		2131.20. Rotary safety eyebolt, light duty, with ball bearing	C20



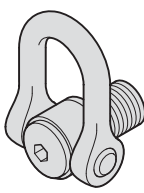
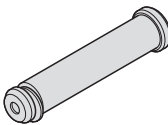
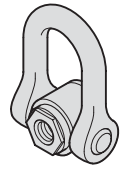
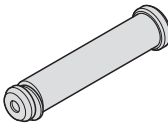

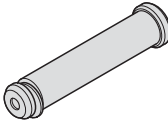
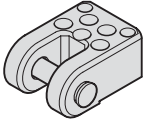

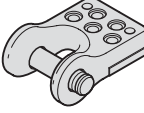
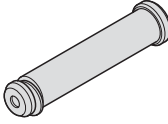
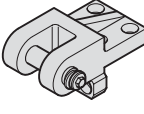
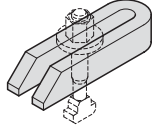
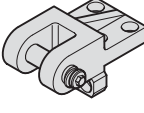
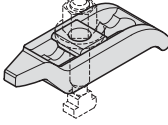
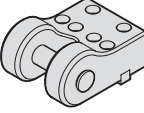
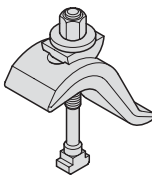
Contents

	2131.21. Rotary safety eyebolt, heavy duty, with ball bearing	C21		2131.34. Attachment point screwable profilift delta	C29
	2131.25. Universal rotary safety eyebolt with oval ring	C22		2131.35. Triple vortice ring	C30
	2131.23. Universal rotary safety eyebolt with eye hook	C23		2131.36. Double vortice hook	C31
	2131.22. Ring block with position lock	C24		2131.37. Double vortice ring	C32
	2131.30. Lifting eye bolt, high tensile	C25		2131.38. Double vortice ring with central device	C33
	2131.31. Attachment point screwable profilift gamma	C26		2131.39. Double vortice ring with internal thread	C34
	2131.32. Attachment point screwable profilift gamma ring nut	C27		2431.40. Double vortex ring screw	C35
	2131.33. Hoisting snap link, omnidirectional	C28		2134.41. Double vortex ring screw with centring	C36

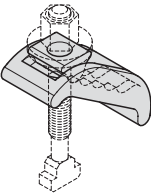
Contents

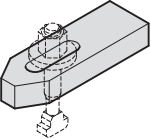
	2131.42. Double vortex ring screw Mega DSS	C37		2132.10. Die lifting bolt with safety ring, VDI 3366	C46
	2131.43. Double vortice ring with internal thread	C38		2132.10.55. Die lifting bolt with safety ring and spring, to VW standard	C47
	2131.50. Attachment point weldable profilift eta	C39		2132.11. Die lifting bolt with safety ring and spring, CNOMO Standard	C48
	2133.11. Lifting flange with bolt with safety ring, to BMW	C40		2132.10.03. .1 Bush for die lifting bolt	C49
	2133.11.10. Lifting flange with bolt with safety ring, to AUDI	C41		2133.12. .1 Die lifting bolt with safety ring, for lifting flange 2133.12.	C50
	2133.12. Lifting flange with bolt with safety ring	C42-43		2140.17. Clamp, forked shape, DIN 6315-B	C52
	2133.13. Lifting flange with bolt with safety ring, with feather key, to CNOMO Standard	C44		2140.15. Clamping claw, goose-neck shape	C52
	2133.15. Lifting flange with bolt with safety ring, with feather key, to BMW	C45		2140.13. Clamping claw, infinitely variable	C53

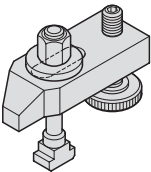
Contents

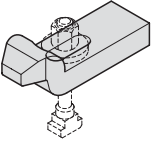
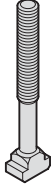
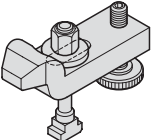
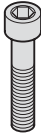
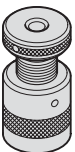
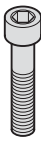
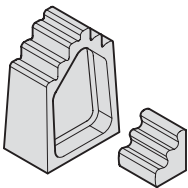
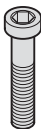
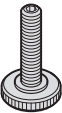
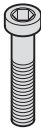
	2140.14. Clamping claw, infinitely variable	C53		2140.32. Hexagon Nut DIN 6330 B	C57
	2140.16. Clamp, straight, DIN 6314	C54		2140.33. Hexagon nut with collar, DIN 6331	C58
	2140.10. Clamp, straight, with setscrew	C54		2140.34. Washer DIN 6340	C58
	2140.18. Clamp, goose neck shape, DIN 6316	C55		2140.30. Screw for T-slot, DIN 787	C59
	2140.11. Clamp, goose neck shape, with setscrew	C55		2192.10. Hexagon socket head cap screw, DIN EN ISO 4762 - Strength class 8.8	C60
	2140.20. Support, adjustable	C56		2192.12. Hexagon socket head cap screw, DIN EN ISO 4762 - Strength class 12.9	C61
	2140.19. Stepped Block DIN 6318	C56		2192.20. Hexagon socket head cap screw, with low profile head and key guide, DIN 6912 - Strength class 8.8	C62
	2140.02. Set screw	C57		2192.40. Hexagon socket head cap screw, with low profile head, DIN 7984 - Strength class 8.8	C63

Contents



2192.30.

C64

Hexagon socket countersunk head cap screw, ISO 10642 - Strength class 8.8



2192.61.

C65

Flat mushroom head screw with hexagon socket

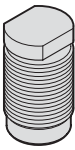

2192.90.

C66

Screw plug



2140.01.01.

C68

Clamping tool set



2140.01.02.

C69

Clamping tool set

Die set shank, straight

Threaded die set shank DIN ISO 10242-1



211.11.

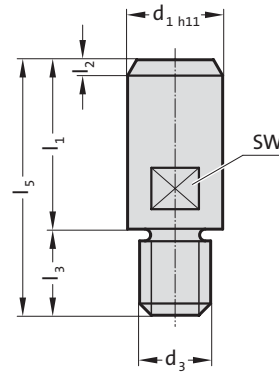

211.11. Die set shank, straight

Order No	d ₁	d ₃	l ₁	l ₂	l ₃	l ₅	SW*
211.11.20.016	20	M16x1,5	40	3	18	58	17
211.11.25.016	25	M16x1,5	45	4	23	68	21
211.11.25.020	25	M20x1,5	45	4	23	68	21
211.11.32.020	32	M20x1,5	56	4	23	79	27
211.11.32.024	32	M24x1,5	56	4	23	79	27
211.11.40.024	40	M24x1,5	70	5	23	93	36
211.11.40.030	40	M30x2	70	5	23	93	36
211.11.50.030	50	M30x2	80	6	28	108	41
211.11.65.042	65	M42x3	100	8	28	128	55

*SW = Width across flats



211.12.

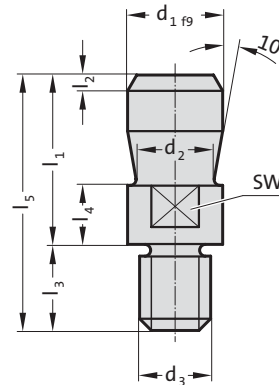

211.12. Threaded die set shank DIN ISO 10242-1

Order No	d ₁	d ₂	d ₃	l ₁	l ₂	l ₃	l ₄	l ₅	SW*
211.12.20.016	20	15	M16x1,5	40	2	18	12	58	17
211.12.25.016	25	20	M16x1,5	45	2.5	23	16	68	21
211.12.25.020	25	20	M20x1,5	45	2.5	23	16	68	21
211.12.32.020	32	25	M20x1,5	56	3	23	16	79	27
211.12.32.024	32	25	M24x1,5	56	3	23	16	79	27
211.12.40.024	40	32	M24x1,5	70	4	23	26	93	36
211.12.40.027	40	32	M27x2	70	4	23	26	93	36
211.12.40.030	40	32	M30x2	70	4	23	26	93	36
211.12.50.030	50	42	M30x2	80	5	28	26	108	41
211.12.65.042	65	53	M42x3	100	8	28	26	128	55

*SW = Width across flats

Die set shank with collar

Bolt-on die set shank, ~DIN ISO 10242-2

211.13.

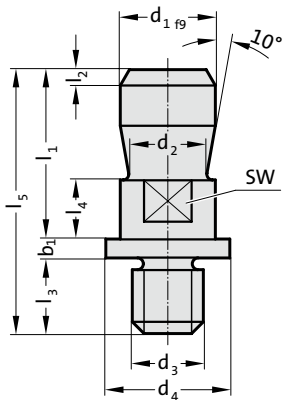

211.13. Die set shank with collar

Order No	d ₁	d ₂	d ₃	l ₁	l ₂	l ₃	l ₄	l ₅	b ₁	SW
211.13.20.016	20	15	M16x1,5	40	2	16	12	61	5	17
211.13.25.016	25	20	M16x1,5	45	2.5	16	16	66	5	21
211.13.25.020	25	20	M20x1,5	45	2.5	20	16	70	5	21
211.13.32.020	32	25	M20x1,5	56	3	20	16	82	6	27
211.13.32.024	32	25	M24x1,5	56	3	24	16	86	6	27
211.13.40.024	40	32	M24x1,5	70	4	24	26	102	8	36
211.13.40.030	40	32	M30x2	70	4	30	26	108	8	36
211.13.50.030	50	42	M30x2	80	5	30	26	118	8	41

211.14.

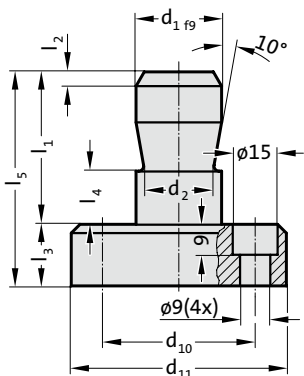

211.14. Bolt-on die set shank, ~DIN ISO 10242-2

Order No	d ₁	d ₂	d ₁₀	d ₁₁	l ₁	l ₂	l ₃	l ₄	l ₅
211.14.20.063	20	15	45	63	40	2	18	12	58
211.14.25.063	25	20	45	63	45	2.5	18	16	63
211.14.25.080	25	20	63	80	45	2.5	18	16	63
211.14.32.097	32	25	80	97	56	3	23	16	79
211.14.32.122	32	25	105	122	56	3	23	16	79
211.14.40.097	40	32	80	97	70	4	23	26	93
211.14.40.122	40	32	105	122	70	4	23	26	93

Coupling spigot with thread

Coupling spigot with flange

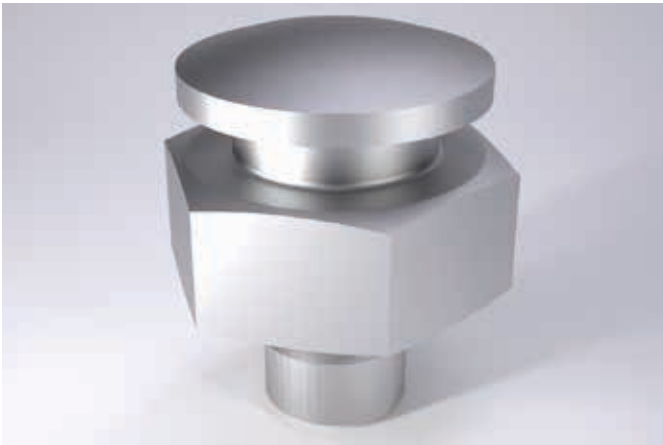

212.11.

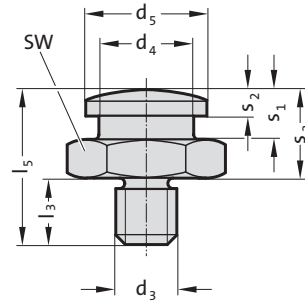

212.11. Coupling spigot with thread

Order No	d ₃	d ₄	d ₅	l ₃	l ₅	s ₁	s ₂	s ₃	SW*
212.11.016	M16x1,5	25	32	18	41	13	6,5	23	36
212.11.020	M20x1,5	32	48	23	64	19	9,5	41	50
212.11.024	M24x1,5	32	48	23	64	19	9,5	41	50
212.11.030	M30x2	32	48	23	66	19	9,5	43	60

*SW = Width across flats



212.15.

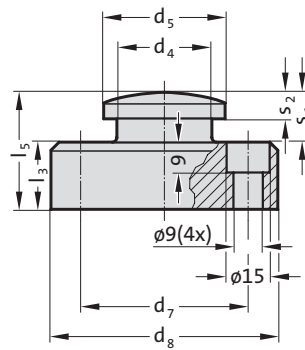

212.15. Coupling spigot with flange

Order No	d ₄	d ₅	d ₇	d ₈	l ₃	l ₅	s ₁	s ₂
212.15.063	25	32	46	63	18	31	13	6,5
212.15.080	32	48	63	80	18	37	19	9,5
212.15.097	32	48	80	97	23	42	19	9,5
212.15.122	32	48	105	122	23	42	19	9,5

Spigot holder

Screw-in lifter stud VDI 3366

212.16.

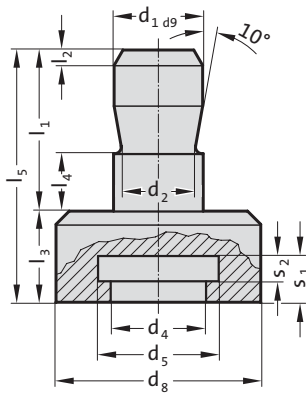

212.16. Spigot holder

Order No	Work area											
	d ₁	d ₂	d ₄	d ₅	d ₈	l ₁	l ₂	l ₃	l ₄	l ₅	s ₁	s ₂
212.16.025	25	20	26	33	56	45	4	25	16	70	12.6	7
212.16.032	32	25	33	49	80	56	4	30	16	86	18.6	10
212.16.040	40	32	33	49	80	70	5	30	26	100	18.6	10

213.12.

VDI 3366

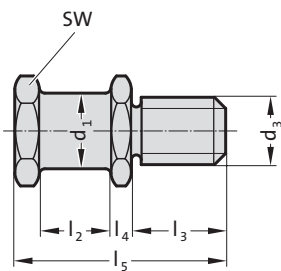

213.12. Screw-in lifter stud VDI 3366

Order No	d ₁	d ₃	l ₂	l ₃	l ₄	l ₅	SW*	Lifting capacity [kg]
213.12.016	16	M16	20	28	5	58	24	320
213.12.020	20	M20	22	34	6	68	30	500
213.12.024	25	M24	25	38	8	78	36	1000
213.12.030	32	M30	32	45	10	95	41	1500
213.12.036	40	M36	40	56	12	118	50	2500

*SW = Width across flats

Screw-in lifter stud with cable securing device



2130.03.

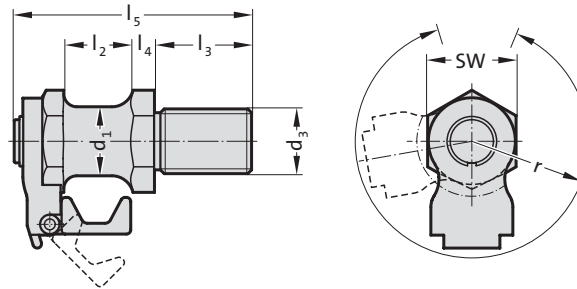

Note:

For opening the cable safety device, use key 2130.00.03.01 (to be ordered separately).

2130.03. Screw-in lifter stud with cable securing device

Order No	d ₁	d ₃	l ₂	l ₃	l ₄	l ₅	SW	r	Lifting capacity [kg]
2130.03.020	20	M20	22	34	6.5	8.5	30	38	500
2130.03.024	25	M24	25	38	8	9	36	42	1000
2130.03.030	32	M30	32	45	10	10	41	50	1500
2130.03.036	40	M36	40	56	12	11	50	57	2500

Lifter stud VDI 3366

Lifter stud with cable securing device, with welded disc

2130.11.

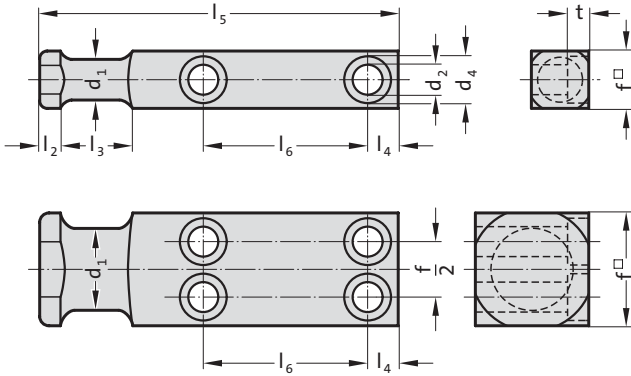

2130.11. Lifter stud VDI 3366



Order No	d ₁	d ₂	d ₄	f	l ₂	l ₃	l ₄	l ₅	l ₆	t	Number of screw holes	Lifting capacity [kg]
2130.11.020	16	9	15	20	6	20	10	80	34	9	2	320
2130.11.025	20	11	18	25	8	25	10	90	37	11	2	630
2130.11.035	25	13.5	20	35	8	30	12	100	38	13	2	1250
2130.11.040	32	17.5	26	40	10	32	16	120	46	17.5	2	2000
2130.11.050	40	22	33	50	10	40	18	140	54	21.5	2	3200
2130.11.060	50	26	40	60	12	45	22	160	59	25.5	2	5000
2130.11.080	63	22	33	80	12	50	20	200	78	21.5	4	8000
2130.11.100	80	26	40	100	15	65	25	250	100	25.5	4	12500
2130.11.120	100	33	48	120	15	80	30	300	125	32	4	20000

2130.12.

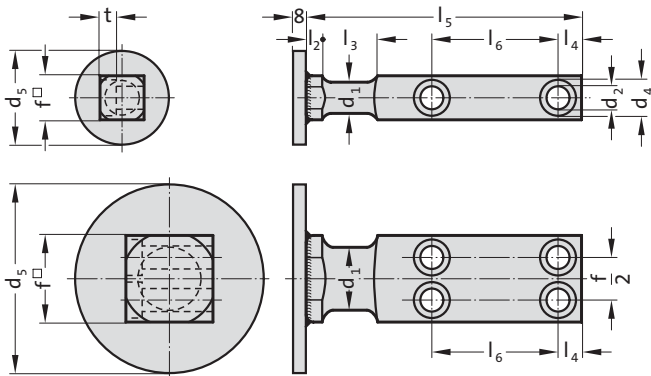

2130.12. Lifter stud with cable securing device, with welded disc



Order No	d ₁	d ₂	d ₄	d ₅ *	f	l ₂	l ₃	l ₄	l ₅	l ₆	t	Number of screw holes	Lifting capacity [kg]
2130.12.020	16	9	15	60	20	6	20	10	80	34	9	2	320
2130.12.025	20	11	18	70	25	8	25	10	90	37	11	2	630
2130.12.035	25	13.5	20	70	35	8	30	12	100	38	13	2	1250
2130.12.040	32	17.5	26	110	40	10	32	16	120	46	17.5	2	2000
2130.12.050	40	22	33	110	50	10	40	18	140	54	21.5	2	3200
2130.12.060	50	26	40	150	60	12	45	22	160	59	25.5	2	5000
2130.12.080	63	22	33	150	80	12	50	20	200	78	21.5	4	8000
2130.12.100	80	26	40	150	100	15	65	25	250	100	25.5	4	12500
2130.12.120	100	33	48	150	120	15	80	30	300	125	32	4	20000

*Pulley for cable securing device welded on

Lifter stud with cable securing device



2130.13.

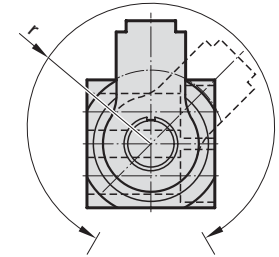
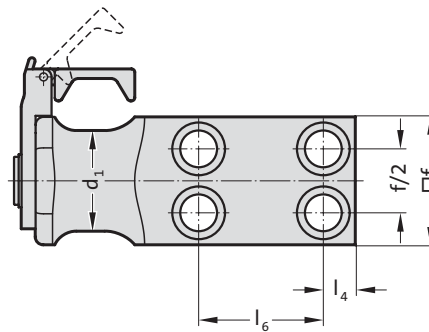
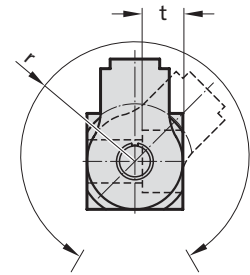
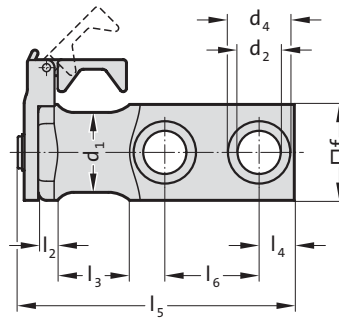

Note:

For opening the cable safety device, use key 2130.00.03.01 (to be ordered separately).

2130.13. Lifter stud with cable securing device

Order No	d ₁	d ₂	d ₄	f	l ₂	l ₃	l ₄	l ₅	l ₆	r	t	Number of screw holes	Lifting capacity [kg]
2130.13.025	20	11	18	25	8	25	10	99	37	38	11	2	630
2130.13.035	25	13.5	20	35	8	30	12	112.5	38	42	13	2	1250
2130.13.040	32	17.5	26	40	10	32	16	132.5	46	52	17.5	2	2000
2130.13.050	40	22	33	50	10	40	18	152.5	54	60	21.5	2	3200
2130.13.060	50	26	40	60	12	45	22	173	59	66	25.5	2	5000
2130.13.080	63	22	33	80	15	50	20	213.5	78	80	21.5	4	8000

Lifter stud



213.13.

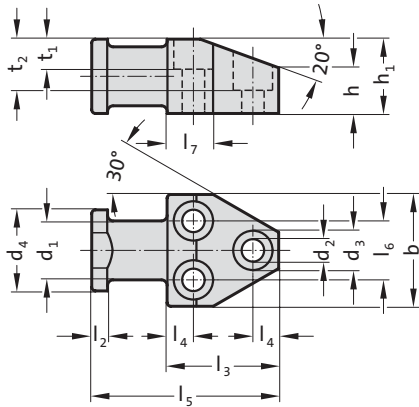

213.13. Lifter stud

Order No	b	d ₁	d ₂	d ₃	d ₄	h	h ₁	l ₂	l ₃	l ₄	l ₅	l ₆	l ₇	t ₁	t ₂	Lifting capacity [kg]
213.13.060	60	32	13.5	20	44	24	40	8	60	14	100	32	24	15	29	2000
213.13.080	80	40	17.5	26	60	32	50	10	70	16	120	44	26	20	35.5	3500
213.13.100	100	50	22	33	70	40	65	12	88	20	145	56	30	25	46.5	6000

Lifting eye bolt, high tensile



2131.10.

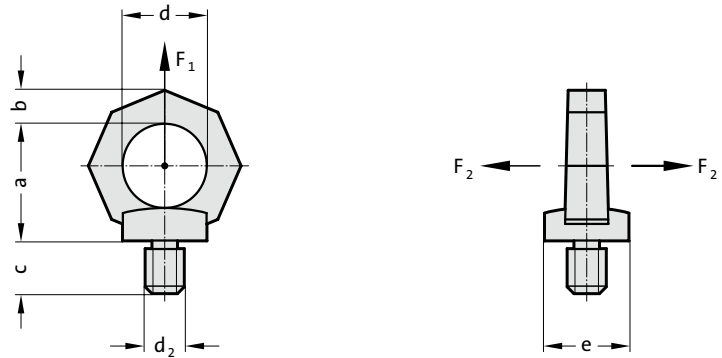

Description:

During use check that the eyebolt is firmly seated.
 Rotation during the lifting operation must be avoided.
 It will not rotate automatically to the correct load angle.
 Not approved for mining applications.

Material:

1.6541, heavy duty heat treated.
 100% electromagnetically crack tested, to EN 1677-1, safety factor 4:1.

Note:

Ensure that the bolting surface is flat. Thread must be screwed in completely.
 Form: = octagonal, Grade 8
 Identification: clear indication of permissible load for F₂ category critical loads (not permissible for DIN 580)

2131.10. Lifting eye bolt, high tensile

Order No	d ₂	c	a	b	d	e
2131.10.006	M6	12	34	11	25	25
2131.10.008	M8	12	34	11	25	25
2131.10.010	M10	15	34	11	25	25
2131.10.012	M12	18	41	13	30	30
2131.10.014	M14	21	48	15	35	35
2131.10.016	M16	24	48	15	35	35
2131.10.020	M20	30	55	17	40	40
2131.10.024	M24	36	70	21	50	50
2131.10.030	M30	45	85	26	60	60
2131.10.036	M36	54	130	43	90	100
2131.10.042	M42	63	130	43	90	100
2131.10.048	M48	67	130	43	90	100

Max. carried load "G" in tonnes for various types of attachment

Type of attachment, Arrangement of the suspension points	F ₁ ↑	F ₂ ↑	↑ ↓	↑ ↓	↑ ↓	↑ ↓	↑ ↓	↑ ↓
Number of lines	1	1	2	2	2 symmetrical	2	3 and 4 symmetrical	3 and 4
Angle of inclination/ load direction	0°	90°	0°	90°	0-45° 45-60°	asymmetrical	0-45° 45-60°	asymmetrical
Order No	carried load in tonnes							
2131.10.006	0,4		0,8					
2131.10.008	0,8		1,6					
2131.10.010	1		2					
2131.10.012	1,6		3,2					
2131.10.014	3		6					
2131.10.016	4		8					
2131.10.020	6		12					
2131.10.024	8		16					
2131.10.030	12		24					
2131.10.036	16		32					
2131.10.042	24		48					
2131.10.048	32		64					

We recommend that you use the eyebolt 2131.11. that is adjustable in the direction of force for the type of suspension with no details of carried loads!



Lifting eye bolt, rotatable

2131.11.

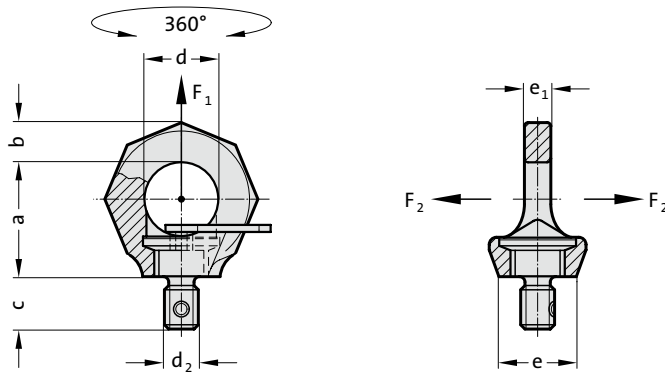

Description:

During use check that the hexagon socket screw is firmly seated. Can be set for the direction of application so that there is no accidental turning and flipping over. Captive hexagon socket screw. No tools are required as the hexagon socket screw is supplied with a hardened star profile key. The star profile key engages in the hexagon socket. It can be screwed and unscrewed by hand. Make sure that the ring is free to rotate through 360° when the unit is screwed in.

Material:

1.6541, forged, heavy duty heat treated.
100% electromagnetically crack tested, to EN 1677-4, safety factor 4:1.

Note:

Ensure that the bolting surface is flat. Thread must be screwed in completely.
Form: octagonal – clearly distinguishable to DIN 580 eye bolt
Identification: clear indication of permissible load

2131.11. Lifting eye bolt, rotatable

Order No	d ₂	c	a	b	d	e	e ₁
2131.11.008	M8	12	35	11	25	25	9
2131.11.010	M10	15	35	11	25	25	9
2131.11.012	M12	18	42	13	30	30	10
2131.11.016	M16	24	49	15	35	36	13
2131.11.020	M20	30	58	17	40	41	16
2131.11.024	M24	36	70	20	49	51	19
2131.11.030	M30	45	87	26	60	66	24
2131.11.036	M36	54	103	32	72	76	29
2131.11.042	M42	63	121	37	84	86	33
2131.11.048	M48	72	138	42	94	100	42

Max. carried load "G" in tonnes for various types of attachment

Type of attachment, Arrangement of the suspension points	F ₁ ↑ G	F ₂ ↑ G	G	G	2 symmetrical	2 asymmetrical	3 and 4 symmetrical	3 and 4 asymmetrical		
Number of lines	1	1	2	2	2	2	3 and 4	3 and 4		
Angle of inclination/ load direction	0°	90°	0°	90°	0–45° 45–60°	asymmetrical	0–45° 45–60°	asymmetrical		
Order No	carried load in tonnes									
2131.11.008	1	0,3	2	0,6	0,42	0,3	0,3	0,63	0,45	0,3
2131.11.010	1	0,4	2	0,8	0,56	0,4	0,4	0,84	0,6	0,4
2131.11.012	2	0,75	4	1,5	1	0,75	0,75	1,6	1,12	0,75
2131.11.016	4	1,5	8	3	2,1	1,5	1,5	3,15	2,25	1,5
2131.11.020	6	2,3	12	4,6	3,22	2,3	2,3	4,83	3,45	2,3
2131.11.024	8	3,2	16	6,4	4,48	3,2	3,2	6,7	4,8	3,2
2131.11.030	12	4,5	24	9	6,3	4,5	4,5	9,4	6,7	4,5
2131.11.036	16	7	32	14	9,8	7	7	14,7	10,5	7
2131.11.042	24	9	48	18	12,6	9	9	18,9	13,5	9
2131.11.048	32	12	64	24	16,8	12	12	25,2	18	12

Hoisting snap link



2131.16.

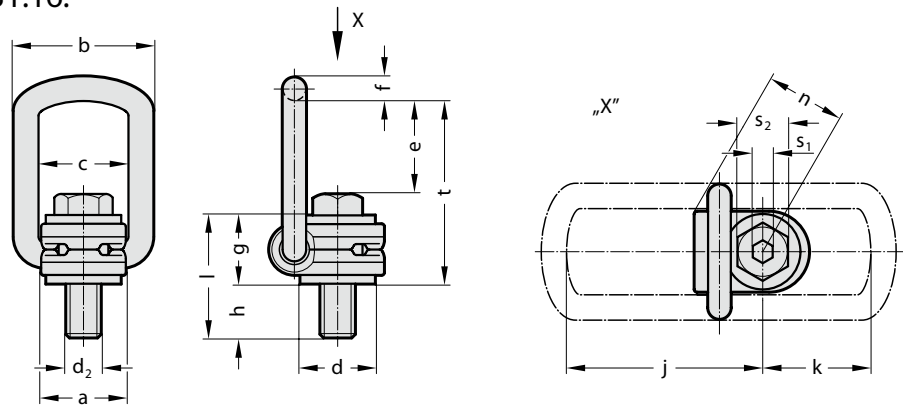

Description:

The hinged unit is free to rotate through 360°, self-align with the direction of pull and folding. The hoisting Snap Link must be installed in the stress direction before loading, must be able to move freely and may not be supported at an angle.
Do not rotate under load.
Full load bearing capacity in any direction.
Complete with a 100% crack-checked outer and inner hexagonal bolt for universal tool use.

Note:

Ensure even screw-in surface, threads must be screwed in completely.

2131.16. Hoisting snap link

Order No	a	b	c	d	e	f	g	h	Standard	j	k	l	Standard	d ₂	n	s ₁	s ₂	t	Tightening torque [Nm]
2131.16.008.011	30	52	34	24	40	10	29	11	11	75.3	45	40	40	M8	32	5	13	75	30
2131.16.010.015	30	52	34	24	39	10	29	15	15	75.3	45	44	44	M10	32	6	17	75	60
2131.16.012.018	32	52	34	26	38	10	29	18	18	77.3	45	47	47	M12	32	8	19	75	150
2131.16.016.022	34.5	56	38	30	39	13.5	36	22	22	86.3	47	58	58	M16	38	10	24	85	150
2131.16.020.032	50	82	54	45	55	17	43	32	32	113.8	64	75	75	M20	48	12	30	110	400
2131.16.024.037	50	82	54	45	67	17	43	37	37	129.8	78	80	80	M24	48	14	36	125	760
2131.16.030.049	60	103	65	60	67	22.5	61	49	49	151.3	80	110	110	M30	67	17	46	147	1000
2131.16.036.063	77	122	82	70	97	26.5	77	63	63	203.3	113	140	140	M36	79	22	55	196	800
2131.16.042.073	77	122	82	70	94	26.5	77	73	73	204.3	113	150	150	M42	79	24	65	196	1000
2131.16.042.063	95	156	100	85	109	36	87	63	63	228	130	150	150	M42	100	24	65	22	1500
2131.16.048.073	95	156	100	95	105	36	87	73	73	231	130	160	160	M48	100	27	75	222	2000

Max. carried load "G" in tonnes for various types of attachment

Type of attachment/Arrangement of the suspension points										
Number of lines	1	1	2	2	2 symmetrical	2	3 and 4 symmetrical	3 and 4	3 and 4	
Angle of inclination/load direction	0°	90°	0°	90°	0-45°	45-60°	asymmetrical	0-45°	45-60°	asymmetrical
Order No.	carried load in tonnes									
2131.16.008.011	0,63	0,63	1,26	1,26	0,88	0,63	0,63	1,3	0,94	0,63
2131.16.010.015	0,9	0,9	1,8	1,8	1,26	0,9	0,9	1,9	1,35	0,9
2131.16.012.018	1,35	1,35	2,7	2,7	1,9	1,35	1,35	2,8	2	1,35
2131.16.016.022	2	2	4	4	2,8	2	2	4,2	3	2
2131.16.020.032	3,5	3,5	7	7	4,9	3,5	3,5	7,35	5,25	3,5
2131.16.024.037	4,5	4,5	9	9	6,3	4,5	4,5	9,5	6,75	4,5
2131.16.030.049	6,7	6,7	13,4	13,4	9,4	6,7	6,7	14	10	6,7
2131.16.036.063	8	8	16	16	11,2	8	8	16,8	12	8
2131.16.042.073	10	10	20	20	14	10	10	21	15	10
2131.16.042.063	15	15	30	30	21	15	15	31,5	22,5	15
2131.16.048.073	20	20	40	40	28	20	20	42	30	20



Hoisting snap link, with ball bearing

2131.17.

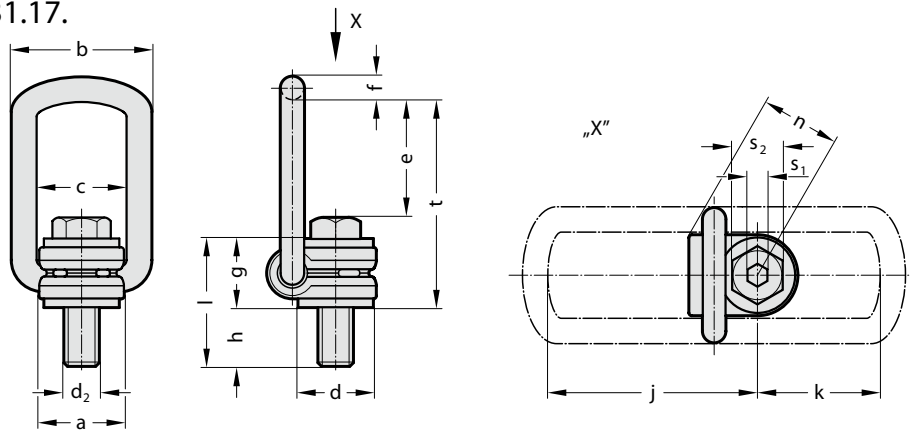

Description:

The hinged unit is free to rotate through 360°, self-align with the direction of pull and folding. The hoisting Snap Link must be installed in the stress direction before loading, must be able to move freely and may not be supported at an angle.
 Rotatable under load.
 Full load bearing capacity in any direction.
 Complete with a 100% crack-checked outer and inner hexagonal bolt for universal tool use.

Note:

Ensure even screw-in surface, threads must be screwed in completely.

2131.17. Hoisting snap link, with ball bearing

Order No	a	b	c	d	e	f	g	h	j	k	l	d ₂	n	s ₁	s ₂	t	Tightening torque [Nm]
2131.17.008	30	52	34	24	40	10	29	11	75	43	40	M8	32	5	13	75	30
2131.17.010	30	52	34	24	39	10	29	15	75	43	44	M10	32	6	17	75	60
2131.17.012	32	52	34	26	38	10	29	18	75	43	47	M12	32	8	19	75	150
2131.17.016	34.5	56	40	30	39	13.5	36	22	86	46	58	M16	38	10	24	85	150
2131.17.020	54	82	60	45	53	17	43	32	113	61	75	M20	48	12	30	110	400
2131.17.024	54	82	60	45	66	17	43	37	130	76	80	M24	48	14	36	125	760
2131.17.030	63	103	69	55	66	22.5	61	49	151	79	110	M30	66	17	46	147	1000

Max. carried load "G" in tonnes for various types of attachment

Type of attachment/Arrangement of the suspension points	F ₁ ↑ G	F ₂ ↑ G	G	G	G	G	G	G	G	G
Number of lines	1	1	2	2	2 symmetrical	2	3 and 4 symmetrical	3 v 4		
Angle of inclination/load direction	0°	90°	0°	90°	0-45°	45-60°	asymmetrical	0-45°	45-60°	asymmetrical
Order No.	carried load in tonnes									
2131.17.008	0,6	0,6	1,2	1,2	0,8	0,6	0,6	1,2	0,9	0,6
2131.17.010	0,9	0,9	1,8	1,8	1,2	0,9	0,9	1,9	1,3	0,9
2131.17.012	1,35	1,35	2,7	2,7	1,9	1,35	1,35	2,8	2	1,35
2131.17.016	2,5	2,5	5	5	3,5	2,5	2,5	5,3	3,7	2,5
2131.17.020	3,5	3,5	7	7	4,9	3,5	3,5	7,4	5,2	3,5
2131.17.024	4,5	4,5	9	9	6,3	4,5	4,5	9,5	6,7	4,5
2131.17.030	6,7	6,7	13,4	13,4	9,4	6,7	6,7	14,2	10	6,7

Rotary safety eyebolt, light duty, with ball bearing



2131.20.

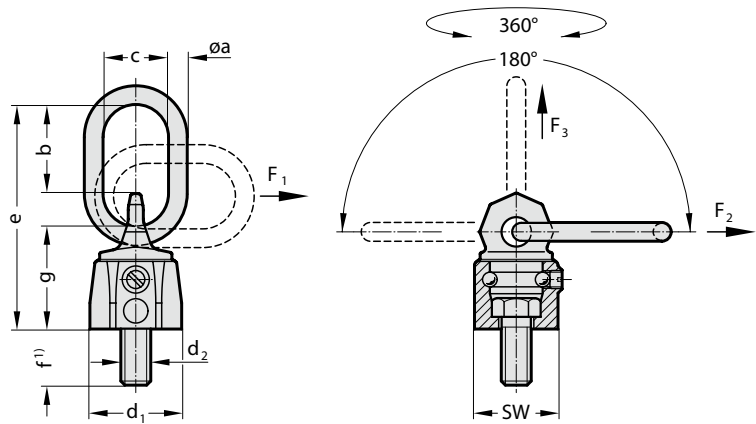

Description:

For loads that are turned and rotated.
 Mounted on ball-bearings – can be rotated through 360° under load (F₃).
 Cannot be rotated under full load at 90° to the threaded fixing (F₁, F₂).
 Not suitable for extended rotational movement when fully loaded.
 Can be loaded on all sides with a safety factor 4:1.
 High-strength suspension eye conforming to EN 1677-4
 1) Other thread lengths available upon request.

Note:

Ensure that the bolting surface is flat. Thread must be screwed in completely.
 The threaded connection on the transported load must be suitable for transferring forces.

2131.20. Rotary safety eyebolt, light duty, with ball bearing

Order No	Rated carrying capacity		d ₂	f	a	b	c	d ₁	e	g	SW*
	for F ₁ [t]										
2131.20.008.013	0.3		M8	13	8	31	29	30	76	36	28
2131.20.010.017	0.45		M10	17	8	31	29	33.5	78	38	30

*SW = Width across flats

Max. carried load “G” in tonnes for various types of attachment

Type of attachment, Arrangement of the suspension points												
Number of lines	1	1	2	2	2 symmetrical	2	2	3 and 4 symmetrical	3 and 4	3 and 4		
Angle of inclination/ load direction	0°	90°	0°	90°	0–45°	45–60°	asymmetrical	0–45°	45–60°	asymmetrical		
Order No	Thread		carried load in tonnes									
2131.20.008.013	M 8		0,6	0,3 (0,4)	1,2	0,6 (0,8)	0,42 (0,56)	0,3 (0,4)	0,3 (0,4)	0,63 (0,84)	0,45 (0,6)	0,3 (0,4)
2131.20.010.017	M10		0,9	0,45 (0,6)	1,8	0,9 (1,2)	0,63 (0,84)	0,45 (0,6)	0,45 (0,6)	0,94 (1,26)	0,67 (0,9)	0,45 (0,6)



Rotary safety eyebolt, heavy duty, with ball bearing

2131.21.

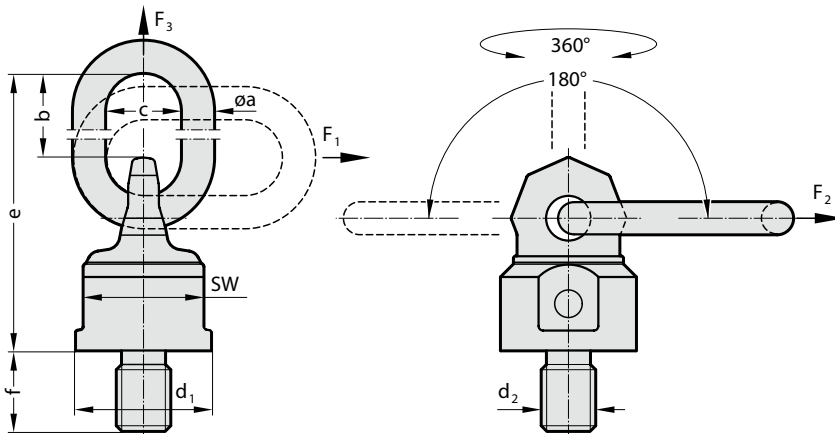

Description:

For loads that are turned and rotated.
 Mounted on ball-bearings – can be rotated through 360° under load (F_3).
 Cannot be rotated under full load at 90° to the threaded fixing (F_1, F_2).
 Not suitable for extended rotational movement when fully loaded.
 Can be loaded on all sides with a safety factor 4:1.

Note:

Ensure that the bolting surface is flat. Thread must be screwed in completely.
 The threaded connection on the transported load must be suitable for transferring forces.

2131.21. Rotary safety eyebolt, heavy duty, with ball bearing

Order No	Rated carrying capacity for F_1 [t]	d_2	f	a	b	c	d_1	e	SW*
2131.21.036	8	M36	54	22	86	50	90	208	80
2131.21.042	12	M42	63	26	111	65	98	235	85
2131.21.045	12	M45	67	26	111	65	98	235	85
2131.21.048	13	M48	68	26	111	65	98	235	85
2131.21.056	16	M56	84	32	119	70	120	274	95
2131.21.064	16	M64	94	32	119	70	120	274	95
2131.21.090	40	M90	135	46	170	110	170	378	145

*SW = Width across flats

Max. carried load "G" in tonnes for various types of attachment

Type of attachment, Arrangement of the suspension points	$F_3 \uparrow$ G	$F_1(F_2) \uparrow$ G	$F_3 \uparrow$ G	$F_1(F_2) \uparrow$ G	$F_3 \uparrow$ G	$F_1(F_2) \uparrow$ G	$F_3 \uparrow$ G	$F_1(F_2) \uparrow$ G			
Number of lines	1	1	2	2	2 symmetrical	2 asymmetrical	3 and 4 symmetrical	3 and 4 asymmetrical			
Angle of inclination/ load direction	0°	90°	0°	90°	0–45°	45–60°	0–45°	45–60°			
Order No	Thread	carried load in tonnes									
2131.21.036	M36	15	8 (10)	30	16 (20)	11,2 (14)	8 (10)	8 (10)	16,8 (21)	12 (15)	8 (10)
2131.21.042	M42	17	12 (13)	34	24 (26)	16,8 (18,2)	12 (13)	12 (13)	25,2 (27,3)	18 (19,5)	12 (13)
2131.21.045	[M45]	18	12 (15)	36	24 (30)	16,8 (21)	12 (15)	12 (15)	25,2 (31,5)	18 (22,5)	12 (15)
2131.21.048	M48	18	13 (16)	36	26 (32)	18,2 (22,4)	13 (16)	13 (16)	27,3 (33,6)	19,5 (24)	13 (16)
2131.21.056	M56	28	16 (22)	56	32 (44)	22,4 (30,8)	16 (22)	16 (22)	33,6 (46,2)	24 (33)	16 (22)
2131.21.064	M64	28	16 (25)	56	32 (50)	22,4 (35)	16 (25)	16 (25)	33,6 (52,5)	24 (37,5)	16 (25)
2131.21.090	M90	50	40 (50)	100	80 (100)	56 (70)	40 (50)	40 (50)	84 (105)	60 (75)	40 (50)

Universal rotary safety eyebolt with oval ring



2131.25.

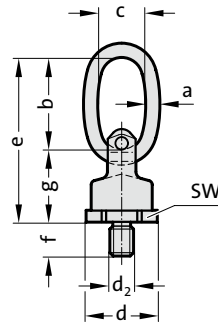

Description:

The universal rotary safety eyebolts with oval ring with double ball bearing for smooth non-jerking action tipping, rotating and turning. Also rotates 90° in direction of screwing in with full load. Not suitable for extended rotational movement when fully loaded. The special design avoids damage to lifting elements and the valuable load when turning. For ring hoists, slings, cables, hooks etc.

Note:

Ensure even screw-in surface, threads must be screwed in completely.

2131.25. Universal rotary safety eyebolt with oval ring

Order No	Rated carrying capacity [t]	d ₂	f	a	b	c	d	e	g	SW*
2131.25.012	0.63	M12	18	9	65	35	40	105	41	36
2131.25.016	1.5	M16	24	11	65	35	46	115	50	41
2131.25.020	2.5	M20	30	13	75	40	61	135	61	55
2131.25.024	4.0	M24	36	16	95	45	78	172	77	70
2131.25.030	5.0	M30	45	21	130	60	95	223	93	85
2131.25.036	8.0	M36	54	24	140	65	100	242	102	90

*SW = Width across flats

Max. carried load “G” in tonnes for various types of attachment

Type of attachment, Arrangement of the suspension points

Type of attachment, Arrangement of the suspension points										
Number of lines	1	1	2	2	2 symmetrical	2 asymmetrical	3 and 4 symmetrical	3 and 4 asymmetrical	3 and 4 asymmetrical	
Angle of inclination/ load direction	0°	90°	0°	90°	0–45°	45–60°	0–45°	45–60°	asymmetrical	
Order No	carried load in tonnes									
2131.25.012	0,63	0,63	1,26	1,26	0,88	0,63	0,63	1,32	0,95	0,63
2131.25.016	1,5	1,5	3,0	3,0	2,1	1,5	1,5	3,15	2,25	1,5
2131.25.020	2,5	2,5	5,0	5,0	3,5	2,5	2,5	5,25	3,75	2,5
2131.25.024	4,0	4,0	8,0	8,0	5,6	4,0	4,0	8,4	6,0	4,0
2131.25.030	6,7	5,0	13,4	10,0	7	5	5	10,5	7,5	5,0
2131.25.036	10,0	8,0	20,0	16,0	11,2	8,0	8,0	16,8	12,0	8,0



Universal rotary safety eyebolt with eye hook

2131.23.

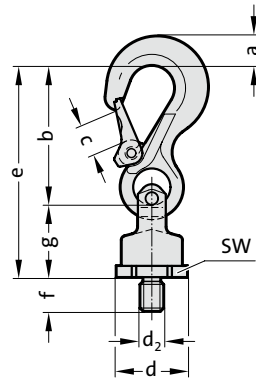

Description:

The universal rotary safety eyebolts with eye hooks with double ball bearing for smooth non-jerking action tipping, rotating and turning. Also rotates 90° in direction of screwing in with full load. Not suitable for extended rotational movement when fully loaded. The special design avoids damage to lifting elements and the valuable load when turning. For ring hoists, slings, cables, hooks etc.

Note:

Ensure even screw-in surface, threads must be screwed in completely.

2131.23. Universal rotary safety eyebolt with eye hook

Order No	Rated carrying capacity [t]	d ₂	f	a	b	c	d	e	g	SW*
2131.23.012	0,63	M12	18	13	75	18	40	116	41	36
2131.23.016	1,5	M16	24	20	97	25	46	147	50	41
2131.23.020	2,5	M20	30	28	126	30	61	187	61	55
2131.23.024	4	M24	36	36	150	35	78	227	77	70
2131.23.030	5	M30	45	37	174	40	95	267	93	85
2131.23.036	8	M36	54	49	208	48	100	310	102	90

*SW = Width across flats

Max. carried load "G" in tonnes for various types of attachment

Type of attachment, Arrangement of the suspension points

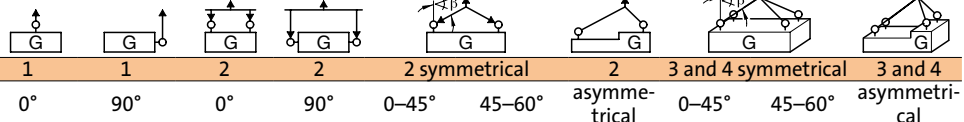

Order No	carried load in tonnes									
2131.23.012	0,63	0,63	1,26	1,26	0,88	0,63	0,63	1,32	0,95	0,63
2131.23.016	1,5	1,5	3,0	3,0	2,1	1,5	1,5	3,15	2,25	1,5
2131.23.020	2,5	2,5	5,0	5,0	3,5	2,5	2,5	5,25	3,75	2,5
2131.23.024	4,0	4,0	8,0	8,0	5,6	4,0	4,0	8,4	6,0	4,0
2131.23.030	6,7	5,0	13,4	10,0	7	5,0	5,0	10,5	7,5	5,0
2131.23.036	10,0	8,0	20,0	16,0	11,2	8,0	8,0	16,8	12,0	8,0

Ring block with position lock

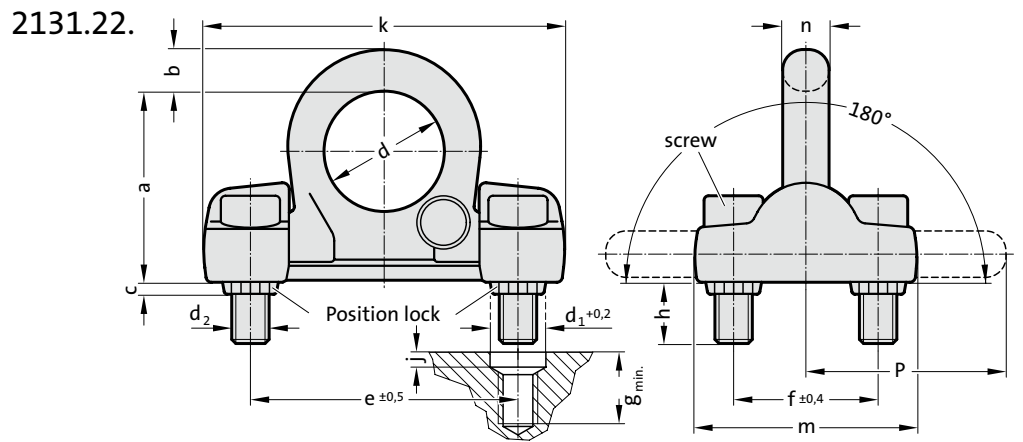
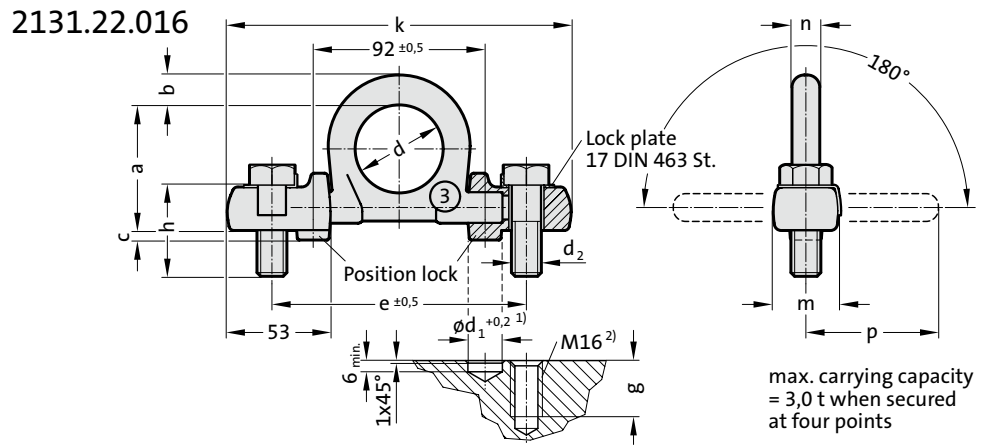

Description:

The position locks protect the fixing bolts against bending and shear stresses. The ring can be folded down.

Note:

- 1) Drill the holes for the position locks first.
- 2) Fix the ring block in the position lock and then tap the holes. Ensure that the bolting surface is flat. See also loading of eyebolts. The threaded connection on the transported load must be suitable for transferring forces.

Fixing:

- Only use 100% crack tested bolts.
- Once bolts have been in use for some time, check that they are firmly seated.
- Minimum grade of screws, see table: "Y"
- 2131.22.016.: Only use hexagonal bolts to ISO 4014. Fit washers before tightening and securing bolts (tightening torque 120 Nm).
- 2131.22.020./030.: Use only hexagon socket head screws conforming to ISO 4762 (2131.22.020 tightening torque 300 Nm, 2131.22.030 tightening torque 600 Nm).

2131.22. Ring block with position lock

Order No	Rated carrying capacity [t]	d ₂	h	a	b	c	d	d ₁	e	f	g	j	k	m	n	y	p
2131.22.016	3	M16	50	67	16	5	48	18	136	-	30	-	178	34	16	10.9	71
2131.22.020	10	M20	45	102	22	6	65	30	143	78	50	8	213	120	25	12.9	100
2131.22.030	16	M30	63	131	30	8	90	46	198	104	70	10	270	170	32	12.9	134

Max. carried load "G" in tonnes for various types of attachment

Type of attachment, Arrangement of the suspension points	F ₃ ↑	F ₁ (F ₂) ↑	F ₃ ↑	F ₁ (F ₂) ↑	F ₃ ↑	F ₁ (F ₂) ↑	F ₃ ↑	F ₁ (F ₂) ↑	F ₃ ↑	F ₁ (F ₂) ↑	F ₃ ↑	F ₁ (F ₂) ↑
Number of lines	1	1	2	2	2 symmetrical	2	3 and 4 symmetrical	3 and 4	1	1	2	2
Angle of inclination/ load direction	0°	90°	0°	90°	0-45°	45-60°	asymm.	0-45°	45-60°	asymm.	0-45°	45-60°
Order No	Thread											
	carried load in tonnes											
2131.22.016	2 × M16	3	3	6	6	4,2	3	3	6,3	4,5	3	3
2131.22.020	4 × M20	10	10	20	20	14	10	10	21	15	10	10
2131.22.030	4 × M30	16	16	32	32	22,4	16	16	33,6	24	16	16



Lifting eye bolt, high tensile

2131.30.

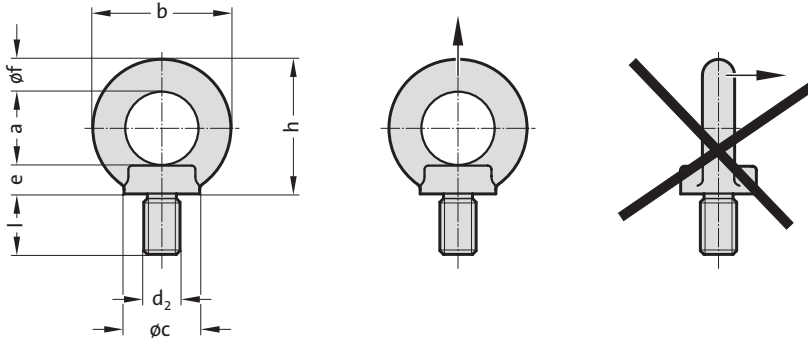

Description:

Only tighten eyebolts hand-tight. Not suitable for diagonal pull. Avoid turning movements during transport.

Material:

Alloyed steel, hardened and tempered, quality class 8

Note:

Load capacity according to operating instructions or load capacity table in the specified directions of pull.

When selecting the arrangement, make sure that unequal loading does not occur, e.g. if:

- no free adjustment is possible in the direction of pull
- direction of pull does not lie in the specified range

Safety factory 4

2131.30. Lifting eye bolt, high tensile

Order No	Rated carrying capacity [t]	d ₂	l	a	b	c	e	f	h
2131.30.006	0.4	M6	13	25	45	25	10	10	45
2131.30.008	0.8	M8	13	25	45	25	10	10	45
2131.30.010	1	M10	17	25	45	25	10	10	45
2131.30.012	1.6	M12	21	35	63	35	14	14	62
2131.30.014	3	M14	21	35	63	35	14	14	62
2131.30.016	4	M16	27	35	63	35	14	14	62
2131.30.020	6	M20	30	50	90	50	20	20	90
2131.30.024	8	M24	36	50	90	50	20	20	90
2131.30.030	12	M30	45	60	108	65	24	24	109
2131.30.036	16	M36	54	70	126	75	26	28	128
2131.30.042	24	M42	63	80	144	85	30	32	147
2131.30.048	32	M48	68	90	166	100	35	38	168

Max. carrying capacity "G" in tonnes for various types of attachment

Type of attachment										
Number of lines	1	1	2	2	2	2	3+4	3+4	2	3+4
Angle of inclination/ load direction	0°	90°	0°	90°	0-45°	45-60°	0-45°	45-60°	asymmetrical	asymmetrical
Order No	carrying capacity in tonnes									
2131.30.006	0.4	0.8								
2131.30.008	0.8	1.6								
2131.30.010	1	2								
2131.30.012	1.6	3.2								
2131.30.014	3	6								
2131.30.016	4	8								
2131.30.020	6	12								
2131.30.024	8	16								
2131.30.030	12	24								
2131.30.036	16	32								
2131.30.042	24	48								
2131.30.048	32	64								

Load the eyebolt in the pull direction only!
For these lifting types, use the turnable eyebolt 2131.31. or the turnable attachment point 2131.34

Attachment point screwable profilift gamma



2131.31.

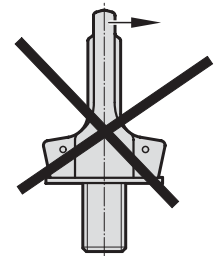
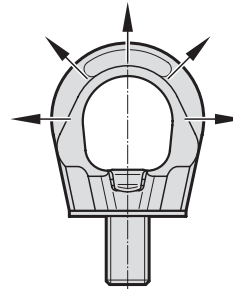
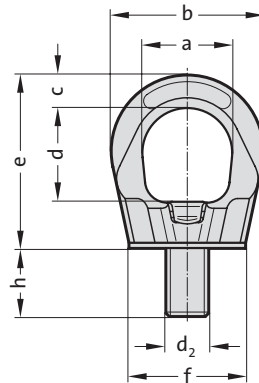

Description:

When replacing, make sure the Allen screw is seated firmly. Adjustable in the direction of force, thus no unintended opening up and overtwisting! Screwing in and out by hand possible. The ring must be able to be turned 360° in the screwed tight state.

Material:

Structural parts: High-strength chrome nickel alloyed Q & T steel.
Screws: High-strength screws strength class 10.9, 100 % crack tested

Note:

Ensure even screw-in surface, threads must be screwed in completely. Each attachment point is provided with an individual serial number. Information about installation and removal, see operating instructions. Load capacity according to operating instructions or load capacity table in the specified directions of pull. Set attachment point in permitted loading direction before loading.

When selecting the arrangement, make sure that unequal loading does not occur, e.g. if:
- no free adjustment is possible in the direction of pull
- direction of pull does not lie in the specified range
Safety factor 4

Other lengths (n) on request!

2131.31. Attachment point screwable profilift gamma

Order No	Rated carrying capacity [t]	d ₂	n	a	b	c	d	e	f
2131.31.008	0.3	M8	15	25	45	10	27	53	35
2131.31.010	0.5	M10	15	25	45	10	27	53	35
2131.31.012	0.7	M12	20	30	55	12	32	63	43
2131.31.016	1.5	M16	25	35	64	14	36	70	50
2131.31.020	2.3	M20	30	40	69	16	41	78	54
2131.31.024	3.2	M24	35	50	86	18	50	93	69
2131.31.030	4.9	M30	45	60	110	25	60	114	90
2131.31.036	7	M36	55	70	132	31	70	136	108
2131.31.042	9	M42	65	80	152	36	72	153	126
2131.31.048	12	M48	75	95	179	42	88	179	148

Max. carrying capacity “G” in tonnes for various types of attachment

Type of attachment										
Number of lines	1	1	2	2	2	2	3+4	3+4	2	3+4
Angle of inclination/ load direction	0°	90°	0°	90°	0-45°	45-60°	0-45°	45-60°	asymmetrical	asymmetrical
Order No	tightening torque [Nm]		carrying capacity in tonnes							
2131.31.008	1	0.3	2	0.6	0.4	0.3	0.6	0.4	0.3	0.3
2131.31.010	1.5	0.5	3	1	0.7	0.5	1	0.7	0.5	0.5
2131.31.012	2	0.7	4	1.4	1	0.7	1.4	1	0.7	0.7
2131.31.016	4	1.5	8	3	2.1	1.5	3	2.2	1.5	1.5
2131.31.020	5	2.3	10	4.6	3.2	2.3	4.8	3.4	2.3	2.3
2131.31.024	6.5	3.2	13	6.4	4.5	3.2	6.7	4.8	3.2	3.2
2131.31.030	12	4.9	24	9.8	6.9	4.9	10.3	7.3	4.9	4.9
2131.31.036	15	7	30	14	9.8	7	14.7	10.5	7	7
2131.31.042	22	9	44	18	12.6	9	18.9	13.5	9	9
2131.31.048	30	12	60	24	16.8	12	25	18	12	12



Attachment point screwable profilift gamma ring nut

2131.32.

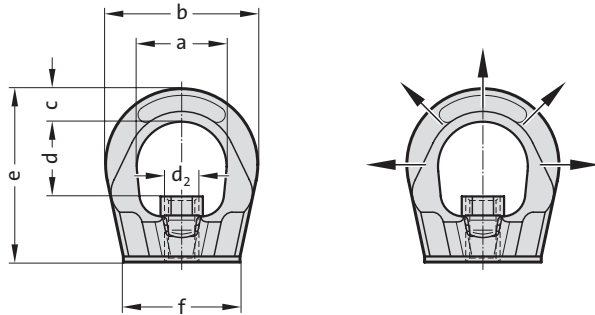

Description:

Pay attention to firm seating of the ring nut when inserting. Adjustable in the direction of force, thus no unintended opening up and overtwisting! Screwing in and out by hand possible. The ring must be able to be turned 360° in the screwed tight state.

Material:

Structural parts: High-strength chrome nickle alloyed Q & T steel.
Nuts: High-strength nuts, strength class 10, 100 % crack tested

Note:

Ensure even screw-in surface, threads must be screwed in completely. Each attachment point is provided with an individual serial number. Information about installation and removal, see operating instructions. Load capacity according to operating instructions or load capacity table in the specified directions of pull. Set attachment point in permitted loading direction before loading.

When selecting the arrangement, make sure that unequal loading does not occur, e.g. if:
- no free adjustment is possible in the direction of pull
- direction of pull does not lie in the specified range
Safety factor 4.

2131.32. Attachment point screwable profilift gamma ring nut

Order No	Rated carrying capacity [t]	d ₂	a	b	c	d	e	f
2131.32.008	0.3	M8	25	45	10	21	55	35
2131.32.010	0.5	M10	25	45	10	21	55	35
2131.32.012	0.7	M12	30	55	12	25	65	43
2131.32.016	1.5	M16	35	64	14	29	72	50
2131.32.020	2.3	M20	40	69	16	34	80	54
2131.32.024	3.5	M24	50	86	18	40	95	69
2131.32.030	4.9	M30	60	110	25	47	115	90

Max. carrying capacity “G” in tonnes for various types of attachment

Type of attachment										
Number of lines	1	1	2	2	2	2	3+4	3+4	2	3+4
Angle of inclination/ load direction	0°	90°	0°	90°	0–45°	45–60°	0–45°	45–60°	asymmetrical	asymmetrical
Order No	carrying capacity in tonnes									
2131.32.008	1	0.3	2	0.6	0.4	0.3	0.6	0.4	0.3	0.3
2131.32.010	1.5	0.5	3	1	0.7	0.5	1	0.7	0.5	0.5
2131.32.012	2	0.7	4	1.4	1	0.7	1.4	1	0.7	0.7
2131.32.016	4	1.5	8	3	2.1	1.5	3	2.2	1.5	1.5
2131.32.020	4.5	2.3	9	4.6	3.2	2.3	4.8	3.4	2.3	2.3
2131.32.024	5	3.5	10	7	4.9	3.5	7.4	5.2	3.5	3.5
2131.32.030	12	4.9	24	1.4	6.9	4.9	10.3	7.3	4.9	4.9

Hoisting snap link, omnidirectional



2131.33.

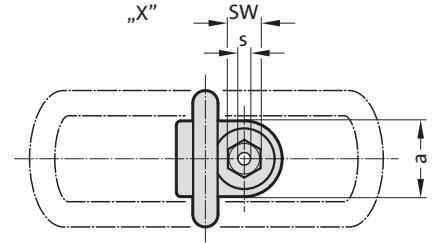
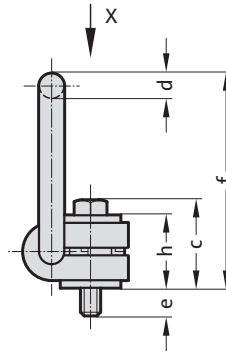
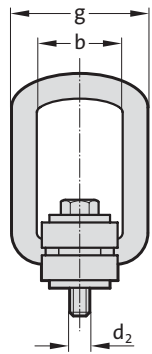

Description:

The hinged unit is free to rotate through 360°, self-align with the direction of pull and folding. The hoisting Snap Link must be installed in the stress direction before loading, must be able to move freely and may not be supported at an angle.
Do not rotate under load.
Full load bearing capacity in any direction.
Complete with a 100% crack-checked outer and inner hexagonal bolt for universal tool use.

Material:

Alloyed tool steel

Note:

Ensure even screw-in surface, threads must be screwed in completely.

2131.33. Hoisting snap link, omnidirectional

Order No	Rated carrying capacity [t]	d ₂	e	g	a	b	c	d	f	h	s	SW	Tightening torque [Nm]
2131.33.008.055	0.3	M8	12	55	30	35	35	11	84	28	6	13	30
2131.33.010.055	0.63	M10	16	55	30	35	36	11	86	29	6	17	60
2131.33.012.057	1	M12	18	57	33	37	44	14	98	36	8	19	100
2131.33.014.057	1.2	M14	21	57	33	37	45	14	98	36	10	22	120
2131.33.016.057	1.5	M16	24	57	33	37	46	14	98	36	10	24	150
2131.33.018.082	2	M18	26	82	50	54	57	17	142	44	12	30	200
2131.33.020.082	2.5	M20	30	82	50	54	57	17	142	44	12	30	250
2131.33.024.082	4	M24	36	82	50	54	59	17	142	44	14	36	400
2131.33.027.099	4	M27	38	99	60	65	79	23	170	62	17	41	400
2131.33.030.099	5	M30	48	99	60	65	81	23	170	62	17	46	500
2131.33.036.099	7	M36	54	99	60	65	86	23	177	63	22	55	700
2131.33.036.124	8	M36	62	124	77	85	101	27	225	78	22	55	800
2131.33.042.124	10	M42	72	124	77	85	104	27	225	78.5	24	65	1000
2131.33.042.158	15	M42	63	158	95	104	115	36	256	89	24	65	1500
2131.33.048.158	20	M48	72	158	95	104	119	36	258	89	27	75	2000

Max. carrying capacity "G" in tonnes for various types of attachment

Type of attachment, Arrangement of the suspension points										
Number of lines	1	1	2	2	2 symmetrical	2 symmetrical	3 and 4 symmetrical	3 and 4 symmetrical	2 asymmetrical	3 and 4 asymmetrical
Angle of inclination/ load direction	0°	90°	0°	90°	0-45°	45-60°	0-45°	45-60°	asymmetrical	asymmetrical
Order No	carrying capacity in tonnes									
2131.33.008.055	0.3	0.3	0.6	0.6	0.42	0.3	0.63	0.45	0.3	0.3
2131.33.010.055	0.63	0.63	1.26	1.26	0.88	0.63	1.32	0.95	0.63	0.63
2131.33.012.057	1	1	2	2	1.4	1	2.1	1.5	1	1
2131.33.014.057	1.2	1.2	2.4	2.4	1.7	1.2	2.5	1.8	1.2	1.2
2131.33.016.057	1.5	1.5	3	3	2.1	1.5	3.1	2.2	1.5	1.5
2131.33.018.082	2	2	4	4	2.8	2	4.2	3	2	2
2131.33.020.082	2.5	2.5	5	5	3.5	2.5	5.2	3.7	2.5	2.5
2131.33.024.082	4	4	8	8	5.6	4	8.4	6	4	4
2131.33.027.099	4	4	8	8	5.6	4	8.4	6	4	4
2131.33.030.099	5	5	10	10	7	5	10.5	7.5	5	5
2131.33.036.099	7	7	14	14	9.8	7	14.7	10.5	7	7
2131.33.036.124	8	8	16	16	11.2	8	16.8	12	8	8
2131.33.042.124	10	10	20	20	14	10	21	15	10	10
2131.33.042.158	15	15	30	30	21	15	31.5	22.5	15	15
2131.33.048.158	20	20	40	40	28	20	42	30	20	20



Attachment point screwable profilift delta

2131.34.

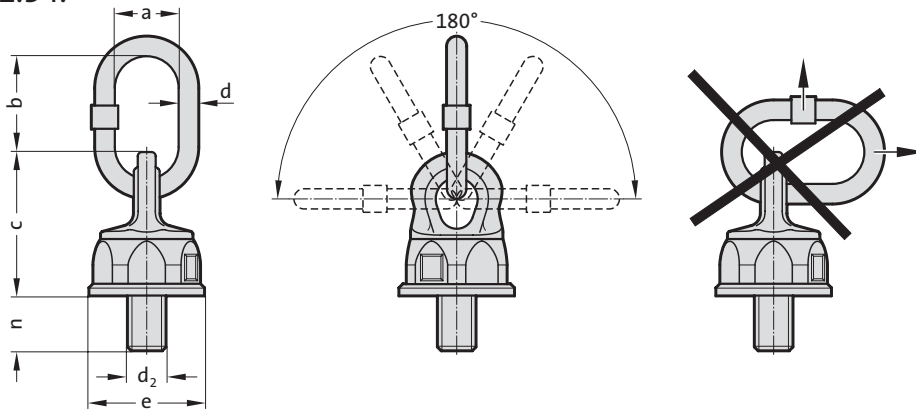

Description:

For loads which are turned and flipped.
 Ball-bearing-mounted – under load turnable by 360°
 Not suitable for continuous turning movements under full load.

Material:

Structural parts: High-strength chrome nickle alloyed Q & T steel.
 Screws: High-strength screws strength class 12.9, 100 % crack tested

Note:

Ensure even screw-in surface, threads must be screwed in completely.
 The threaded connection on the transport belt must be suitable for the force transmission.
 Each attachment point is provided with an individual serial number

Information about installation and removal, see operating instructions.
 Load capacity according to operating instructions or load capacity table in the specified directions of pull.

When selecting the arrangement, make sure that unequal loading does not occur, e.g. if:
 - no free adjustment is possible in the direction of pull
 - direction of pull does not lie in the specified range
 - when fit closely at edges or surfaces
 Safety factor 4

* 2131.34.014 only by request!

2131.34. Attachment point screwable profilift delta

Order No	Rated carrying capacity [t]	d ₂	n	a	b	c	d	e
2131.34.008	0.3	M8	20	30	38	54	13	38
2131.34.010	0.5	M10	20	30	38	54	13	38
2131.34.012	0.7	M12	22	35	48	54	13	38
2131.34.014*	1	M14	22	35	48	54	13	38
2131.34.016	1.5	M16	33	35	48	54	13	38
2131.34.020	2.5	M20	33	35	55	75	16	55
2131.34.024	4	M24	40	40	66	82	17	63
2131.34.030	6	M30	40	50	70	92	23	72
2131.34.036	8	M36	55	50	91	124	23	92
2131.34.042	10	M42	60	65	91	124	27	92
2131.34.048	12.5	M48	68	65	116	124	27	92

Max. carrying capacity "G" in tonnes for various types of attachment

Type of attachment	1		2		2		3+4		2		3+4	
Number of lines	1	1	2	2	2	2	3+4	3+4	2	2	3+4	3+4
Angle of inclination/load direction	0°	90°	0°	90°	0-45°	45-60°	0-45°	45-60°	asymmetrical	asymmetrical	asymmetrical	asymmetrical
Order No	tightening torque [Nm]		carrying capacity in tonnes									
2131.34.008	10	0.6	0.3	1.2	0.6	0.4	0.3	0.6	0.4	0.3	0.3	0.3
2131.34.010	10	1	0.5	2	1	0.7	0.5	1	0.75	0.5	0.5	0.5
2131.34.012	15	1.4	0.7	2.8	1.4	0.95	0.7	1.4	1	0.7	0.7	0.7
2131.34.014*	25	2	1	4	2	1.4	1	2.1	1.5	1	1	1
2131.34.016	30	2.8	1.5	5.6	3	2.1	1.5	3.1	2.1	1.5	1.5	1.5
2131.34.020	80	5	2.5	10	5	3.5	2.5	5.3	3.5	2.5	2.5	2.5
2131.34.024	150	7	4	14	8	5.5	4	8.4	6	4	4	4
2131.34.030	230	10	6	20	12	8.4	6	12.6	9	6	6	6
2131.34.036	450	12.5	8	25	16	11.2	8	16.8	12	8	8	8
2131.34.042	600	16	10	32	20	14	10	21	15	10	10	10
2131.34.048	600	16	12.5	32	25	17.5	12.5	26.5	18	12.5	12.5	12.5

Triple vortice ring



2131.35.

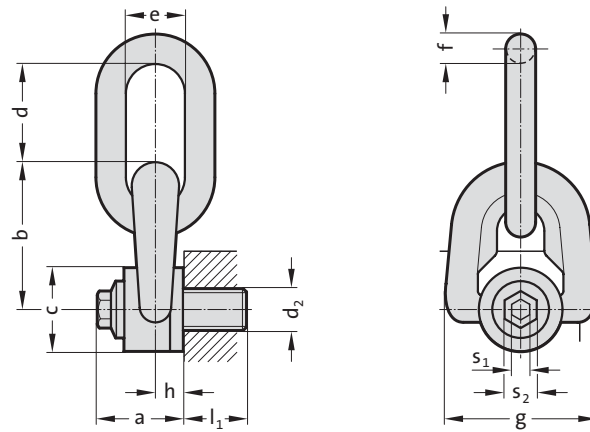

Description:

The triple vortice rings with double bearing mount for smooth tipping, turning and flipping.
 Also turnable 90° for screw-in direction under full load.
 Not suitable for continuous turning movement under full load.
 The optimised design prevents damage to lifting tackle and the valuable load when turning.
 For ring assembly, round slings, wire ropes, hook assemblies, etc.

Material:

High-strength chrome-nickel alloyed Q & T steel,
 Screws: high-strength screws, min. strength category 10.9, 100 % crack inspected

Note:

Ensure even screw-in surface, threads must be screwed in completely.

2131.35. Triple vortice ring

Order No	Rated carrying capacity [t]	d ₂	l ₁	s ₁	s ₂	a	b	c	d	e	f	g	h	Tightening torque [Nm]
2131.35.008	0.3	M8	14	8	16	33	56	30	41	25	10	58	5.5	6
2131.35.010	0.6	M10	17	8	16	33	56	30	41	25	10	58	9.5	10
2131.35.012	1	M12	21	8	16	33	56	30	41	25	10	58	9.5	15
2131.35.014	1.3	M14	23	8	20	45	76	45	56	37	14	79	13	30
2131.35.016	1.6	M16	27	8	20	45	76	45	56	37	14	79	13	50
2131.35.018	2	M18	27	8	20	45	76	45	56	37	14	79	13	70
2131.35.020	2.5	M20	30	8	20	45	81	45	56	37	14	79	13	100
2131.35.022	3	M22	33	14	24	62	105	60	80	45	20	106	19	120
2131.35.024	4	M24	36	14	24	62	105	60	80	45	20	106	19	160
2131.35.027	5	M27	36	14	24	62	105	60	80	45	20	106	19	160
2131.35.030	6.3	M30	45	14	24	62	105	60	80	45	20	106	19	250
2131.35.036	10	M36	54	19	30	81	140	80	111	71	30	148	26.5	320
2131.35.042	12.5	M42	63	19	30	84	146	80	111	71	30	148	26.5	400
2131.35.048	20	M48	68	19	30	100	178	110	135	90	42	180	33	600
2131.35.056	22	M56	78	19	30	104	184	110	135	90	42	190	33	600

Max. carrying capacity “G” in tonnes for various types of attachment

Type of attachment, Arrangement of the suspension points									
Number of lines	1	1	2	2	2 symmetrical	4 symmetrical	2	3 and 4	
Angle of inclination/ load direction	0°	90°	0°	90°	0–45°	45–60°	0–45°	45–60°	
Order No	carrying capacity in tonnes								
2131.35.008	0.3	0.3	0.6	0.6	0.4	0.3	0.6	0.3	0.3
2131.35.010	0.6	0.6	1.2	1.2	0.8	0.6	1.3	0.6	0.6
2131.35.012	1	1	2	2	1.4	1	2.1	1	1
2131.35.014	1.3	1.3	2.6	2.6	1.8	1.3	2.7	1.3	1.3
2131.35.016	1.6	1.6	3.2	3.2	2.2	1.6	3.4	1.6	1.6
2131.35.018	2	2	4	4	2.8	2	4.2	2	2
2131.35.020	2.5	2.5	5	5	3.5	2.5	5.3	2.5	2.5
2131.35.022	3	3	6	6	4.2	3	6.3	3	3
2131.35.024	4	4	8	8	5.6	4	8.4	4	4
2131.35.027	5	5	10	10	7	5	10.5	5	5
2131.35.030	6.3	6.3	12.6	12.6	8.8	6.3	13.2	6.3	6.3
2131.35.036	10	10	20	20	14	10	21	10	10
2131.35.042	12.5	12.5	25	25	17.5	12.5	26.3	12.5	12.5
2131.35.048	20	20	40	40	28	20	42	20	20
2131.35.056	22	22	44	40	30.8	22	46.2	22	22



Double vortice hook

2131.36.

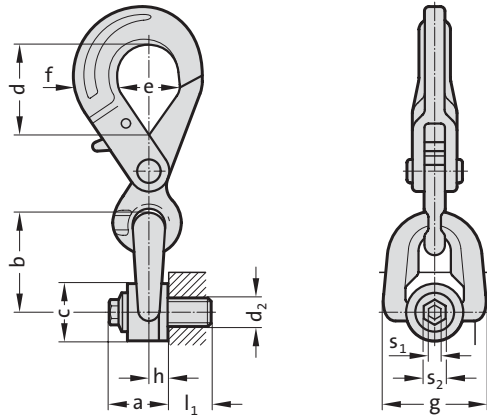

Description:

The double vortice rings with double bearing mount for smooth tipping, turning and flipping.
 Also turnable 90° for screw-in direction under full load.
 Not suitable for continuous turning movement under full load.
 The optimised design prevents damage to lifting tackle and the valuable load when turning.
 For ring assembly, round slings, wire ropes, hook assemblies, etc.

Material:

High-strength chrome-nickel alloyed Q & T steel,
 Screws: high-strength screws, min. strength category 10.9, 100 % crack inspected

Note:

Ensure even screw-in surface, threads must be screwed in completely.

2131.36. Double vortice hook

Order No	Rated carrying capacity [t]	d ₂	l ₁	s ₁	s ₂	a	b	c	d	e	f	g	h	Tightening torque [Nm]
2131.36.008	0.3	M8	14	8	16	33	56	30	44	32	23	58	9.5	6
2131.36.010	0.6	M10	17	8	16	33	56	30	44	32	23	58	9.5	10
2131.36.012	1	M12	21	8	16	33	56	30	44	32	23	58	9.5	15
2131.36.014	1.3	M14	23	8	20	45	76	45	58	46	29	79	13	30
2131.36.016	1.6	M16	27	8	20	45	76	45	58	46	29	79	13	50
2131.36.018	2	M18	27	8	20	45	76	45	58	46	29	79	13	70
2131.36.020	2.5	M20	30	8	20	45	81	45	58	46	29	79	13	100

Max. carrying capacity “G” in tonnes for various types of attachment

Type of attachment, Arrangement of the suspension points										
Number of lines	1	1	2	2	2 symmetrical		4 symmetrical		2	3 and 4
Angle of inclination/ load direction	0°	90°	0°	90°	0–45°	45–60°	0–45°	45–60°	asymmetrical	asymmetrical
Order No	carrying capacity in tonnes									
2131.36.008	0.3	0.3	0.6	0.6	0.4	0.3	0.6	0.3	0.3	0.3
2131.36.010	0.6	0.6	1.2	1.2	0.8	0.6	1.3	0.6	0.6	0.6
2131.36.012	1	1	2	2	1.4	1	2.1	1	1	1
2131.36.014	1.3	1.3	2.6	2.6	1.8	1.3	2.7	1.3	1.3	1.3
2131.36.016	1.6	1.6	3.2	3.2	2.2	1.6	3.4	1.6	1.6	1.6
2131.36.018	2	2	4	4	2.8	2	4.2	2	2	2
2131.36.020	2.5	2.5	5	5	3.5	2.5	5.3	2.5	2.5	2.5

Double vortice ring



2131.37.

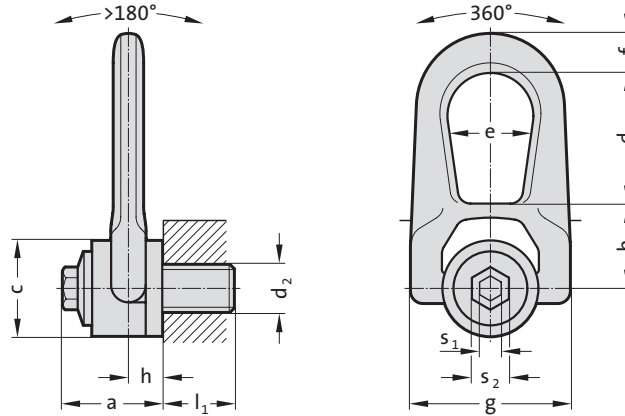

Description:

The double vortex ring was especially designed to guarantee lifting under rotation. Its double joint permits a perfect alignment for load suspension.

Material:

High-strength chrome-nickle alloyed Q & T steel,
Screws: high-strength screws, min. strength category 10.9, 100 % crack inspected

Note:

Ensure even screw-in surface, threads must be screwed in completely. The threaded connection on the transport belt must be suitable for the force transmission. Each attachment point is provided with an individual serial number. Information about installation and removal, see operating instructions. Load capacity according to operating instructions or load capacity table in the specified directions of pull.

When selecting the arrangement, make sure that unequal loading does not occur, e.g. if:

- no free adjustment is possible in the direction of pull
 - direction of pull does not lie in the specified range
- Safety factor 5

2131.37. Double vortice ring

Order No	Rated carrying capacity [t]	d ₂	l ₁	s ₁	s ₂	a	b	c	d	e	f	g	h	Tightening torque [Nm]
2131.37.004	0.05	M4	15	3	16	33	30	30	38	27	14	53	9.5	2
2131.37.005	0.075	M5	15	4	16	33	30	30	38	27	14	53	9.5	3
2131.37.006	0.1	M6	15	5	16	33	30	30	38	27	14	53	9.5	4
2131.37.008	0.3	M8	14	8	16	33	30	30	38	27	14	53	9.5	6
2131.37.010	0.6	M10	17	8	16	33	30	30	38	27	14	53	9.5	10
2131.37.012	1	M12	21	8	16	33	30	30	38	27	14	53	9.5	15
2131.37.014	1.3	M14	23	8	20	45	42	45	54	38	17	76	13	30
2131.37.016	1.6	M16	27	8	20	45	42	45	54	38	17	76	13	50
2131.37.018	2	M18	27	8	20	45	42	45	54	38	17	76	13	70
2131.37.020	2.5	M20	30	8	20	45	42	45	54	38	17	76	13	100
2131.37.022	3	M22	33	14	24	62	55	60	83	55	25	117	19	120
2131.37.024	4	M24	36	14	24	62	55	60	83	55	25	117	19	160
2131.37.027	5	M27	40	14	24	62	55	60	83	55	25	117	19	160
2131.37.030	6.3	M30	45	14	24	62	55	60	83	55	25	117	19	250

Max. carrying capacity "G" in tonnes for various types of attachment

Type of attachment, Arrangement of the suspension points										
Number of lines	1	1	2	2	2 symmetrical	2 symmetrical	3+4 symmetrical	3+4 symmetrical	2	3 and 4
Angle of inclination/ load direction	0°	90°	0°	90°	0-45°	45-60°	0-45°	45-60°	asymmetrical	asymmetrical
Order No	carrying capacity in tonnes									
2131.37.004	0.05	0.05	0.1	0.1	0.07	0.05	0.1	0.05	0.05	0.05
2131.37.005	0.075	0.075	0.15	0.15	0.1	0.6	0.15	0.075	0.075	0.05
2131.37.006	0.1	0.1	0.2	0.2	1.4	0.1	0.2	0.1	0.1	0.1
2131.37.008	0.3	0.3	0.6	0.6	0.4	0.3	0.6	0.3	0.3	0.3
2131.37.010	0.6	0.6	1.2	1.2	0.8	0.6	1.3	0.6	0.6	0.6
2131.37.012	1	1	2	2	1.4	1	2.1	1	1	1
2131.37.014	1.3	1.3	2.6	2.6	1.8	1.3	2.7	1.3	1.3	1.3
2131.37.016	1.6	1.6	3.2	3.2	2.2	1.6	3.4	1.6	1.6	1.6
2131.37.018	2	2	4	4	2.8	2	4.2	2	2	2
2131.37.020	2.5	2.5	5	5	3.5	2.5	5.3	2.5	2.5	2.5
2131.37.022	3	3	6	6	4.2	3	6.3	3	3	3
2131.37.024	4	4	8	8	5.6	4	8.4	4	4	4
2131.37.027	5	5	10	10	7	5	10.5	5	5	5
2131.37.030	6.3	6.3	12.6	12.6	8.8	6.3	13.2	6.3	6.3	6.3



Double vortice ring with central device

2131.38.

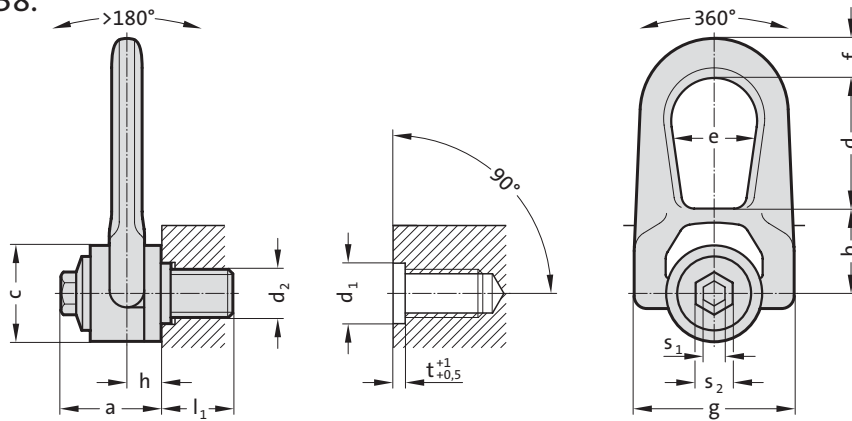

Description:

The double vortex ring with centring device was especially designed to guarantee lifting under rotation. The centring device increases the resistance of the axis in case of lateral mounting.

Material:

High-strength chrome-nickel alloyed Q & T steel,
Screws: high-strength screws, min. strength category 10.9, 100 % crack inspected

Note:

Ensure even screw-in surface, threads must be screwed in completely. The threaded connection on the transport belt must be suitable for the force transmission. Each attachment point is provided with an individual serial number. Information about installation and removal, see operating instructions. Load capacity according to operating instructions or load capacity table in the specified directions of pull.

When selecting the arrangement, make sure that unequal loading does not occur, e.g. if:

- no free adjustment is possible in the direction of pull
 - direction of pull does not lie in the specified range
- Safety factor 5

2131.38. Double vortice ring with central device

Order No	Rated carrying capacity [t]	d ₂	l ₁	s ₁	s ₂	a	b	c	d	e	f	g	h	d ₁	Tolerance d ₁	t	Tightening torque [Nm]
2131.38.004	0.05	M4	15	3	16	33	30	30	38	27	14	53	9.5	16	+0,25/0	3	2
2131.38.005	0.075	M5	15	4	16	33	30	30	38	27	14	53	9.5	16	+0,25/0	3	3
2131.38.006	0.1	M6	15	5	16	33	30	30	38	27	14	53	9.5	16	+0,25/0	3	4
2131.38.008	0.5	M8	14	8	16	33	30	30	38	27	14	53	9.5	16	+0,25/0	3	6
2131.38.010	0.8	M10	17	8	16	33	30	30	38	27	14	53	9.5	20	+0,25/0	3	10
2131.38.012	1.2	M12	21	8	16	33	30	30	38	27	14	53	9.5	20	+0,25/0	3	15
2131.38.014	1.3	M14	23	8	20	45	42	45	54	38	17	76	13	20	+0,30/0	3	30
2131.38.016	2	M16	27	8	20	45	42	45	54	38	17	76	13	20	+0,30/0	3	50
2131.38.018	2	M18	27	8	20	45	42	45	54	38	17	76	13	30	+0,30/0	3	70
2131.38.020	2.7	M20	30	8	20	45	42	45	54	38	17	76	13	30	+0,30/0	3	100
2131.38.022	3	M22	33	14	24	62	55	60	83	55	25	117	19	30	+0,30/0	4	120
2131.38.024	5	M24	36	14	24	62	55	60	83	55	25	117	19	30	+0,30/0	4	160
2131.38.027	5	M27	40	14	24	62	55	60	83	55	25	117	19	36	+0,30/0	4	200
2131.38.030	6.3	M30	45	14	24	62	55	60	83	55	25	117	19	36	+0,30/0	4	250

Max. carrying capacity "G" in tonnes for various types of attachment

Type of attachment, Arrangement of the suspension points										
Number of lines	1	1	2	2	2 symmetrical	3+4 symmetrical	2	3 and 4	2	3 and 4
Angle of inclination/ load direction	0°	90°	0°	90°	0-45°	45-60°	0-45°	45-60°	asymmetrical	asymmetrical
Order No	carrying capacity in tonnes									
2131.38.004	0.05	0.05	0.1	0.1	0.07	0.05	0.1	0.05	0.05	0.05
2131.38.005	0.075	0.075	0.15	0.15	0.1	0.075	0.15	0.075	0.075	0.075
2131.38.006	0.1	0.1	0.2	0.2	0.14	0.1	0.21	0.1	0.1	0.1
2131.38.008	0.5	0.5	1	1	0.7	0.5	1.05	0.5	0.5	0.5
2131.38.010	0.8	0.8	1.6	1.6	1.12	0.8	1.68	0.8	0.8	0.8
2131.38.012	1.2	1.2	2.4	1.68	1.2	1.2	2.52	1.2	1.2	1.2
2131.38.014	1.3	1.3	2.6	2.6	1.82	1.3	2.73	1.3	1.3	1.3
2131.38.016	2	2	4	4	2.8	2	4.2	2	2	2
2131.38.018	2	2	4	4	2.8	2	4.2	2	2	2
2131.38.020	2.7	2.7	5.4	5.4	3.78	2.7	5.67	2.7	2.7	2.7
2131.38.022	3	3	6	6	4.2	3	6.3	3	3	3
2131.38.024	5	5	10	10	7	5	10.5	5	5	5
2131.38.027	5	5	10	10	7	5	10.5	5	5	5
2131.38.030	6.3	6.3	12.6	12.6	8.82	6.3	13.23	6.3	6.3	6.3

Double vortice ring with internal thread



2131.39.

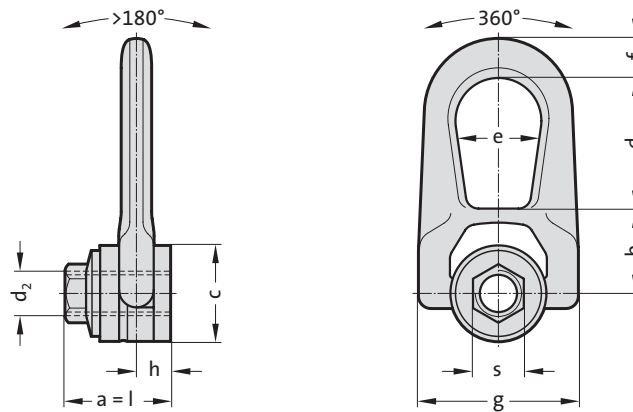

Description:

The double vortex ring with internal thread was especially designed to guarantee lifting under rotation. Its double joint permits a perfect alignment for load suspension.

Material:

High-strength chrome-nickle alloyed Q & T steel

Note:

Ensure even screw-in surface, threads must be screwed in completely. The threaded connection on the transport belt must be suitable for the force transmission.

Each attachment point is provided with an individual serial number
Information about installation and removal, see operating instructions.
Load capacity according to operating instructions or load capacity table in the specified directions of pull.

When selecting the arrangement, make sure that unequal loading does not occur, e.g. if:
- no free adjustment is possible in the direction of pull
- direction of pull does not lie in the specified range
Safety factor 5

2131.39. Double vortice ring with internal thread

Order No	Rated carrying capacity [t]	d ₂	l	s	a	b	c	d	e	f	g	h	Tightening torque [Nm]
2131.39.008	0.3	M8	45	20	45	42	45	54	38	17	76	13	6
2131.39.010	0.6	M10	45	20	45	42	45	54	38	17	76	13	10
2131.39.012	1	M12	45	20	45	42	45	54	38	17	76	13	15
2131.39.014	1	M14	45	20	45	42	45	54	38	17	76	13	30
2131.39.016	1.6	M16	45	20	45	42	45	54	38	17	76	19	50
2131.39.018	2	M18	62	24	62	55	60	83	55	25	117	19	70
2131.39.020	2.5	M20	62	24	62	55	60	83	55	25	117	19	100
2131.39.022	3	M22	62	24	62	55	60	83	55	25	117	19	120

Max. carrying capacity “G” in tonnes for various types of attachment

Type of attachment, Arrangement of the suspension points										
Number of lines	1	1	2	2	2 symmetrical	2 symmetrical	3+4 symmetrical	3+4 symmetrical	2 asymmetrical	3 and 4 asymmetrical
Angle of inclination/ load direction	0°	90°	0°	90°	0–45°	45–60°	0–45°	45–60°	asymmetrical	asymmetrical
Order No	carrying capacity in tonnes									
2131.39.008	0.3	0.3	0.6	0.6	0.4	0.3	0.6	0.3	0.3	0.3
2131.39.010	0.6	0.6	1.2	1.2	0.8	0.6	1.3	0.6	0.6	0.6
2131.39.012	1	1	2	2	1.4	1	2.1	1	1	1
2131.39.014	1.3	1.3	2.6	2.6	1.8	1.3	2.7	1.3	1.3	1.3
2131.39.016	1.6	1.6	3.2	3.2	2.2	1.6	3.4	1.6	1.6	1.6
2131.39.018	2	2	4	4	2.8	2	4.2	2	2	2
2131.39.020	2.5	2.5	5	5	3.5	2.5	5.3	2.5	2.5	2.5
2131.39.022	3	3	6	6	4.2	3	6.3	3	3	3



Double vortex ring screw

2131.40.

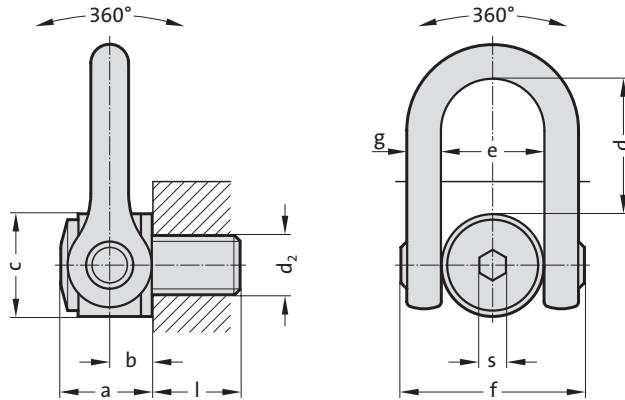

Description:

The double vortex ring screw was especially designed for the lifting and rotating of heavy loads.

Load bearing capacity in all directions and perfect alignment for load suspension.

Material:

High-strength chrome-nickel alloyed Q & T steel,

Screws: high-strength screws, min. strength category 10.9, 100 % crack inspected

Note:

Ensure even screw-in surface, threads must be screwed in completely.

The threaded connection on the transport belt must be suitable for the force transmission.

Each attachment point is provided with an individual serial number

Information about installation and removal, see operating instructions.

Load capacity according to operating instructions or load capacity table in the specified directions of pull.

When selecting the arrangement, make sure that unequal loading does not occur, e.g. if:

- no free adjustment is possible in the direction of pull

- direction of pull does not lie in the specified range

Safety factor 5 - 2131.40.024 through 2131.40.042

Safety factor 4 - 2131.40.045 through 2131.40.100

2431.40. Double vortex ring screw

Order No	Rated carrying capacity [t]	d ₂	l	s	a	b	c	d	e	f	g	Tightening torque [Nm]
2131.40.024	4.5	M24	36	19	61	31	70	104	73	145	29	160
2131.40.030	7.3	M30	45	19	61	31	70	104	73	145	29	250
2131.40.033	8	M33	50	19	61	31	70	104	73	145	29	250
2131.40.036	10	M36	54	19	61	31	70	104	73	145	29	320
2131.40.039	10	M39	58	19	61	31	70	104	73	145	29	320
2131.40.042	12.5	M42	63	19	61	31	70	104	73	145	29	400
2131.40.045	15	M45	63	19	61	31	70	104	73	145	29	400
2131.40.048	20	M48	68	19	79	38	90	125	91	184	36	600
2131.40.052	20	M52	68	19	79	38	90	125	91	184	36	600
2131.40.056	25	M56	78	19	79	38	90	125	91	184	36	600
2131.40.064	32.1	M64	90	19	79	38	95	125	91	184	36	600
2131.40.072	25	M72	90	19	79	38	95	125	91	184	36	600
2131.40.080	32.1	M80	90	19	79	38	95	125	91	184	36	600
2131.40.090	32.1	M90	90	19	79	38	95	125	91	184	36	600
2131.40.100	32.1	M100	90	19	79	38	95	125	91	184	36	600

Max. carrying capacity "G" in tonnes for various types of attachment

Type of attachment, Arrangement of the suspension points
Number of lines

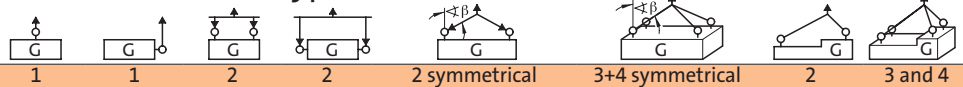

Order No	carrying capacity in tonnes									
2131.40.024	4.5	4.5	9	9	6.3	4.5	9.5	4.5	4.5	4.5
2131.40.030	7.3	7.3	14.6	14.6	10.2	7.3	15.3	7.3	7.3	4.5
2131.40.033	8	8	16	16	11.2	8	16.8	8	8	8
2131.40.036	10	10	20	20	14	10	21	10	10	10
2131.40.039	10	10	20	20	14	10	21	10	10	10
2131.40.042	12.5	12.5	25	25	17.5	12.5	26.3	12.5	12.5	12.5
2131.40.045	15	15	30	30	21	15	31.5	15	15	15
2131.40.048	20	20	40	40	28	20	42	20	20	20
2131.40.052	20	20	40	40	28	20	42	20	20	20
2131.40.056	25	25	50	50	35	25	52.5	25	25	25
2131.40.064	32.1	32.1	64.2	64.2	44.9	32.1	67.4	32.1	32.1	32.1
2131.40.072	25	25	50	50	35	25	52.5	25	25	32.1
2131.40.080	32.1	32.1	64.2	64.2	44.9	32.1	67.4	32.1	32.1	32.1
2131.40.090	32.1	32.1	64.2	64.2	44.9	32.1	67.4	32.1	32.1	32.1
2131.40.100	32.1	32.1	64.2	64.2	44.9	32.1	67.4	32.1	32.1	32.1

Double vortex ring screw with centring



2131.41.

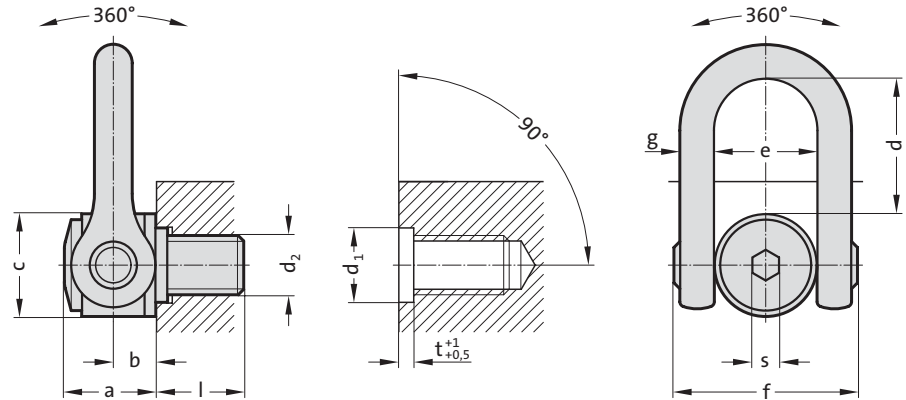

Description:

The double vortex ring screw with centring device was especially designed for the lifting and rotating of heavy loads. The centring device increases the resistance of the axis in case of lateral mounting. Load bearing capacity in all directions and perfect alignment for load suspension.

Material:

High-strength chrome-nickel alloyed Q & T steel,
Screws: high-strength screws, min. strength category 10.9, 100 % crack inspected

Note:

Ensure even screw-in surface, threads must be screwed in completely. The threaded connection on the transport belt must be suitable for the force transmission. Each attachment point is provided with an individual serial number. Information about installation and removal, see operating instructions. Load capacity according to operating instructions or load capacity table in the specified directions of pull.

When selecting the arrangement, make sure that unequal loading does not occur, e.g. if:

- no free adjustment is possible in the direction of pull
- direction of pull does not lie in the specified range

Safety factor 5 - 2131.41.024 through 2131.41.042

Safety factor 4 - 2131.41.045 through 2131.41.064

2134.41. Double vortex ring screw with centring

Order No	Rated carrying capacity [t]	d ₂	l	s	a	b	c	d	e	f	g	d ₁	Tolerance d ₁	t	Tightening torque [Nm]
2131.41.024	5	M24	36	19	61	31	70	104	73	145	29	30	+0,3/0	4	160
2131.41.030	8	M30	45	19	61	31	70	104	73	145	29	36	+0,3/0	4	250
2131.41.033	8	M33	50	19	61	31	70	104	73	145	29	48	+0,3/+0,1	6	250
2131.41.036	11	M36	54	19	61	31	70	104	73	145	29	48	+0,5/+0,1	6	320
2131.41.042	13	M42	63	19	61	31	70	104	73	145	29	48	+0,5/+0,1	6	400
2131.41.045	15	M45	63	19	61	31	70	104	73	145	29	48	+0,5/+0,1	8	400
2131.41.048	22	M48	68	19	79	38	90	125	91	184	36	64	+0,6/+0,1	8	600
2131.41.056	26	M56	78	19	79	38	90	125	91	184	36	64	+0,6/+0,1	8	600
2131.41.064	32.1	M64	90	19	79	38	95	125	91	184	36	74	+0,6/+0,1	10	600

Max. carrying capacity "G" in tonnes for various types of attachment

Type of attachment, Arrangement of the suspension points										
Number of lines	1	1	2	2	2 symmetrical	2 symmetrical	3+4 symmetrical	3+4 symmetrical	2 asymmetrical	3 and 4 asymmetrical
Angle of inclination/ load direction	0°	90°	0°	90°	0-45°	45-60°	0-45°	45-60°	asymmetrical	asymmetrical
Order No	carrying capacity in tonnes									
2131.41.024	5	5	10	10	7	5	10.5	5	5	5
2131.41.030	8	8	16	16	11.2	8	16.8	8	8	8
2131.41.033	8	8	16	16	11.2	8	16.8	8	8	8
2131.41.036	11	11	22	22	15.4	11	23.1	11	11	11
2131.41.042	13	13	26	26	18.2	13	27.3	13	13	13
2131.41.045	15	15	30	30	21	15	31.5	15	15	15
2131.41.048	22	22	44	44	30.8	22	46.2	22	22	22
2131.41.056	26	26	52	52	36.4	26	54.6	26	26	26
2131.41.064	32.1	32.1	64.2	64.2	44.9	32.1	67.4	32.1	32.1	32.1



Double vortex ring screw Mega DSS

2131.42.

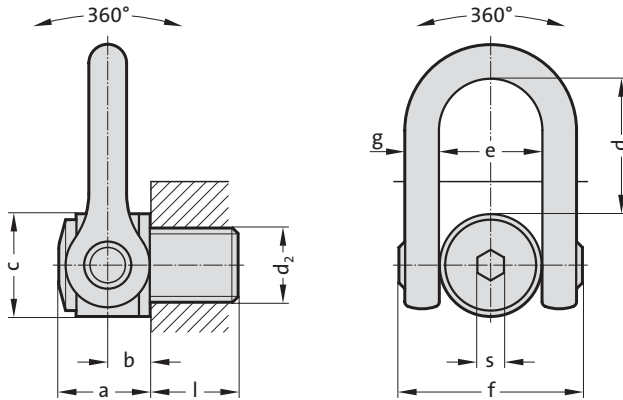

Description:

The Mega double vortex ring screw was specially designed to lift and rotate under a load of up to 50 tons. It can be used directly with the lifting equipment (hook of the travelling crane). Load bearing capacity in all directions and perfect alignment for load suspension.

Material:

High-strength chrome-nickel alloyed Q & T steel,
Screws: high-strength screws, min. strength category 10.9, 100 % crack inspected

Note:

Ensure even screw-in surface, threads must be screwed in completely. The threaded connection on the transport belt must be suitable for the force transmission. Each attachment point is provided with an individual serial number. Information about installation and removal, see operating instructions. Load capacity according to operating instructions or load capacity table in the specified directions of pull.

When selecting the arrangement, make sure that unequal loading does not occur, e.g. if:
- no free adjustment is possible in the direction of pull
- direction of pull does not lie in the specified range
Safety factor 4

2131.42. Double vortex ring screw Mega DSS

Order No	Rated carrying capacity [t]	d ₂	l	s	a	b	c	d	e	f	g	Tightening torque [Nm]
2131.42.064	33	M64	100	36	127.5	64.5	158	186	143	278	57.5	600
2131.42.072	35	M72	110	36	127.5	64.5	158	186	143	278	57.5	700
2131.42.080	40	M80	120	36	127.5	64.5	158	186	143	278	57.5	800
2131.42.090	45	M90	135	36	127.5	64.5	158	186	143	278	57.5	900
2131.42.100	50	M100	150	36	127.5	64.5	158	186	143	278	57.5	1000

Max. carrying capacity “G” in tonnes for various types of attachment

Type of attachment, Arrangement of the suspension points										
Number of lines	1	1	2	2	2 symmetrical	2 symmetrical	3+4 symmetrical	3+4 symmetrical	2 asymmetrical	3 and 4 asymmetrical
Angle of inclination/ load direction	0°	90°	0°	90°	0–45°	45–60°	0–45°	45–60°	asymmetrical	asymmetrical
Order No	carrying capacity in tonnes									
2131.42.064	33	33	66	66	46	33	69	33	33	33
2131.42.072	35	35	70	70	49	35	74	35	35	35
2131.42.080	40	40	80	80	56	40	84	40	40	40
2131.42.090	45	45	90	90	63	45	95	45	45	45
2131.42.100	50	50	100	100	70	50	105	50	50	50

Double vortice ring with internal thread



2131.43.

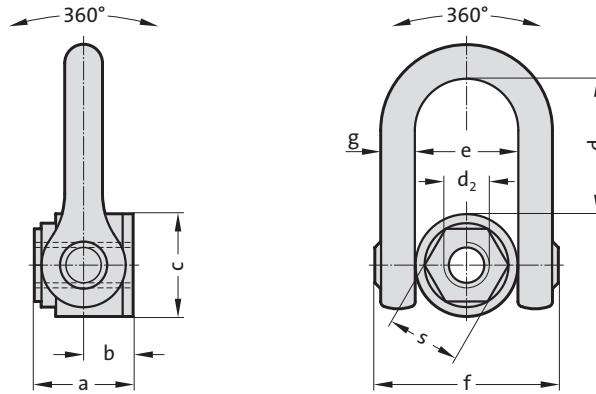

Description:

The double vortex ring with internal thread was especially designed for the lifting and rotating of heavy loads. Its double joint permits a perfect alignment for load suspension.

Material:

High-strength chrome-nickle alloyed Q & T steel

Note:

Ensure even screw-in surface, threads must be screwed in completely. The threaded connection on the transport belt must be suitable for the force transmission.

Each attachment point is provided with an individual serial number
Information about installation and removal, see operating instructions.
Load capacity according to operating instructions or load capacity table in the specified directions of pull.

When selecting the arrangement, make sure that unequal loading does not occur, e.g. if:

- no free adjustment is possible in the direction of pull
 - direction of pull does not lie in the specified range
- Safety factor 5 - 2131.43.024 through 2131.43.042
Safety factor 4 - 2131.43.045 through 2131.43.052

2131.43. Double vortice ring with internal thread

Order No	Rated carrying capacity [t]	d ₂	l	s	a	b	c	d	e	f	g	Tightening torque [Nm]
2131.43.024	4.5	M24	66	50	66	31	70	104	73	145	29	160
2131.43.027	5	M27	66	50	66	31	70	104	73	145	29	200
2131.43.030	7.3	M30	66	50	66	31	70	104	73	145	29	250
2131.43.033	8	M33	66	50	66	31	70	104	73	145	29	250
2131.43.036	10	M36	66	50	66	31	70	104	73	145	29	320
2131.43.039	10	M39	89	60	89	38	95	125	91	184	36	320
2131.43.042	12.5	M42	89	60	89	38	95	125	91	184	36	400
2131.43.045	15	M45	89	60	89	38	95	125	91	184	36	400
2131.43.048	20	M48	89	60	89	38	95	125	91	184	36	600
2131.43.052	20	M52	89	60	89	38	95	125	91	184	36	600

Max. carrying capacity "G" in tonnes for various types of attachment

Type of attachment, Arrangement of the suspension points										
Number of lines	1	1	2	2	2 symmetrical	2 symmetrical	3+4 symmetrical	3+4 symmetrical	2 asymmetrical	3 and 4 asymmetrical
Angle of inclination/ load direction	0°	90°	0°	90°	0-45°	45-60°	0-45°	45-60°	asymmetrical	asymmetrical
Order No	carrying capacity in tonnes									
2131.43.024	4.5	4.5	9	9	6.3	4.5	9.5	4.5	4.5	4.5
2131.43.027	5	5	10	10	7	5	10.5	5	5	5
2131.43.030	7.3	7.3	14.6	14.6	10.2	7.3	15.3	7.3	7.3	7.3
2131.43.033	8	8	16	16	11.2	8	16.8	8	8	8
2131.43.036	10	10	20	20	14	10	21	10	10	10
2131.43.039	10	10	20	20	14	10	21	10	10	10
2131.43.042	12.5	12.5	25	25	17.5	12.5	26.3	12.5	12.5	12.5
2131.43.045	15	15	30	30	21	15	31.5	15	15	15
2131.43.048	20	20	40	40	28	20	42	20	20	20
2131.43.052	20	20	40	40	28	20	42	20	20	20



Attachment point weldable profilift eta

2131.50.

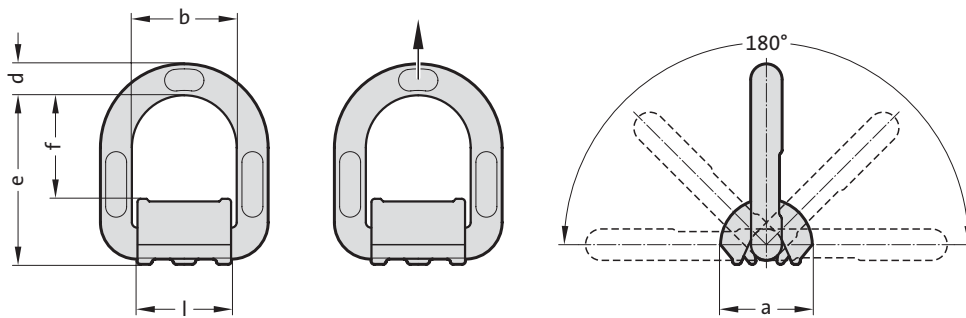

Description:

For welding work, the conditions according to DIN EN ISO 14341 apply. Welding work may only be performed by a welder with qualification according to EN 287-1.

Material:

Weld-on bracket: S355 J2 G3
Ring: high-strength alloyed steel

Note:

Information about installation and removal, see operating instructions. Load capacity according to operating instructions or load capacity table in the specified directions of pull.

When selecting the arrangement, make sure that unequal loading does not occur, e.g. if:

- no free adjustment is possible in the direction of pull
- direction of pull does not lie in the specified range
- when fit closely at edges or surfaces

2131.50. Attachment point weldable profilift eta

Order No	Rated carrying capacity [t]	Size	a	b	d	e	f	l
2131.50.006	1.12	006	36	40	11	67	42	35
2131.50.008	2	008	37	42	13	73	45	37
2131.50.010	3.15	010	41	45	16.5	80	47	40
2131.50.013	5.3	013	61	55	22	97	53	50
2131.50.016	8	016	63	70	25	120	73	64
2131.50.022	15	022	89	97	33	163	92	90

Max. carrying capacity "G" in tonnes for various types of attachment

Type of attachment										
Number of lines	1	1	2	2	2	2	3+4	3+4	2	3+4
Angle of inclination/ load direction	0°	90°	0°	90°	0-45°	45-60°	0-45°	45-60°	asymmetrical	asymmetrical
Order No	carrying capacity in tonnes									
2131.50.006	1.12	1.12	2.24	2.24	1.5	1.12	2.3	1.6	1.12	1.12
2131.50.008	2	2	4	4	2.8	2	4.2	3	2	2
2131.50.010	3.15	3.15	6.3	6.3	4.4	3.15	6.6	4.7	3.15	3.15
2131.50.013	5.3	5.3	10.6	10.6	7.4	5.3	11.2	7.9	5.3	5.3
2131.50.016	8	8	16	16	11.3	8	16.9	12	8	8
2131.50.022	15	15	30	30	21	15	31.8	22.5	15	15



2133.11.

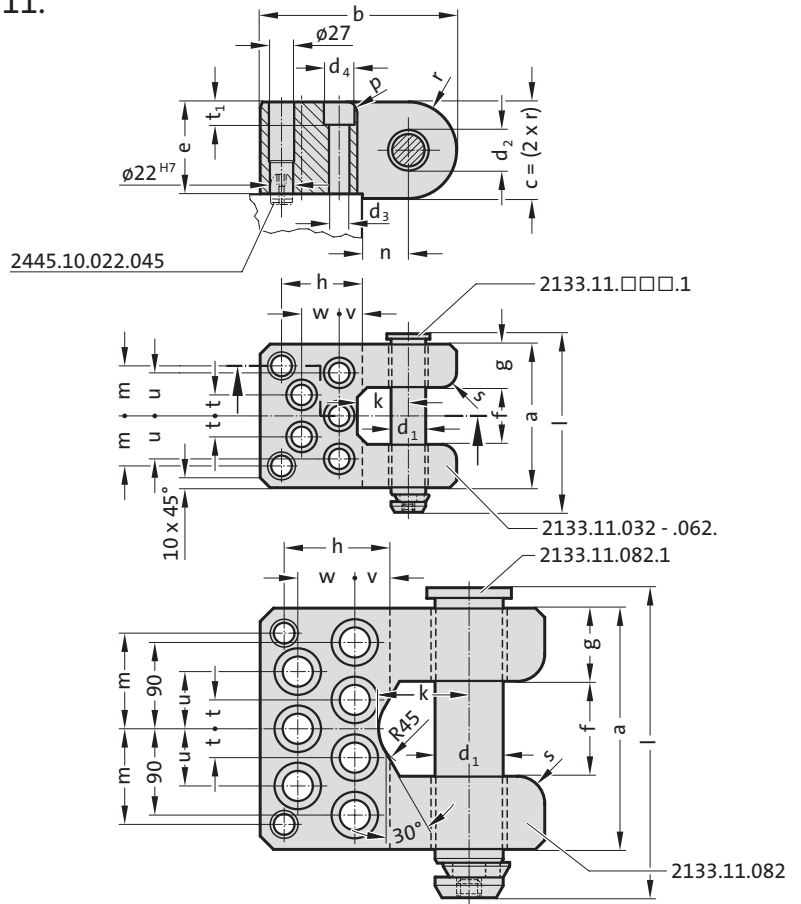

Note:

Centering pin 2445.10.022.045 to be ordered separately

Order No for spare part bolt with safety ring: 2133.11.□□□.1
 Order No for lifting flange with bolt, with safety ring, two centering pins and fixing screws, to BMW: 2133.11.00.15.□□□, 2133.11.00.15.062.36

2133.11. Lifting flange with bolt with safety ring, to BMW

Order No	max. carrying capacity (2 lifting flanges) [kg]*																			Socket head cap screw				
		d_1	d_2	a	b	c	e	f	g	h	k	l	m	n	p	s	t	u	v	w	d_3	d_4	t_1	DIN EN ISO 4762
2133.11.032	6400	30	32	126	185	80	75	50	38	85	50	158	45	40	12	16	20	40	30	35	17.5	26	17.5	M16x80
2133.11.042	10000	40	42	150	210	100	95	60	45	87	55	187	52	50	12	20	22.5	45	25	40	22	33	21.5	M20x100
2133.11.052	16000	50	52	175	240	120	115	75	50	95	70	220	62.5	60	16	24	25	50	35	45	26	40	25.5	M24x120
2133.11.062.36	25000	60	62	200	300	140	130	80	60	145	80	246	77.5	65	20	30	35	65	60	65	39	57	38	M36x160
2133.11.082	36000	80	82	250	300	160	150	100	75	105	95	305	100	90	20	30	30	60	30	60	33	48	32	M30x160

*The maximum permissible load capacity is to be calculated such that two lifting flanges one their own are capable of carrying or turning the tool.



Lifting flange with bolt with safety ring, to AUDI

2133.11.10.

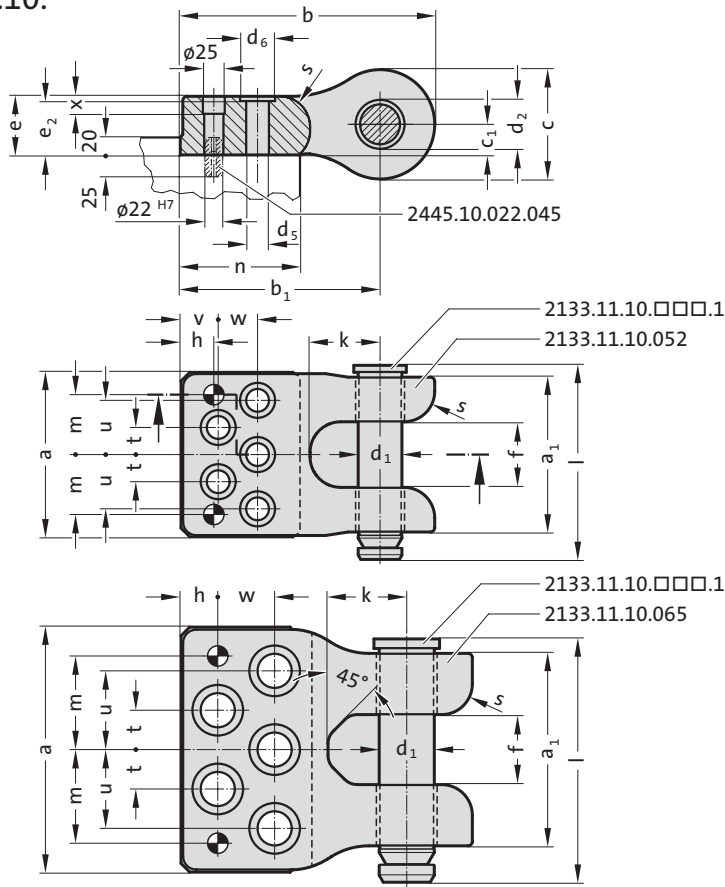

Note:

Centering pin 2445.10.022.045 to be ordered separately

Order No for spare part bolt with safety ring: 2133.11.10.□□□.1

Order No for lifting flange with bolt, with safety ring, two centering pins

and fixing screws, to AUDI: 2133.11.00.10.□□□

2133.11.10. Lifting flange with bolt with safety ring, to AUDI

Order No	max. carrying capacity (2 lifting flanges) [kg]*																					Socket head cap screw				
		d ₁	d ₂	a	a ₁	b	b ₁	c	c ₁	e	f	h	k	l	m	n	s	t	u	v	w	x	d ₅	d ₆	e ₂	DIN EN ISO 4762
2133.11.10.052	16000	50	52	188	177	290	227.5	125	35	67	75	37.5	80	221	68.5	135	35	31	62	42.5	45	20	26	40	65	M24x100
2133.11.00.10.052	16000	50	52	188	177	290	227.5	125	35	67	75	37.5	80	221	68.5	135	35	31	62	42.5	45	20	26	40	65	M24x100
2133.11.10.065	25000	63	65	280	220	333	258	150	47	91	80	42	90	277	107	150	35	45	90	42	65	46	39	58	84	M36x120
2133.11.00.10.065	25000	63	65	280	220	333	258	150	47	91	80	42	90	277	107	150	35	45	90	42	65	46	39	58	84	M36x120

*The maximum permissible load capacity is to be calculated such that two lifting flanges one their own are capable of carrying or turning the tool.

Lifting flange with bolt with safety ring



2133.12.

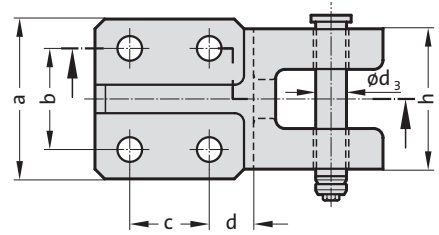
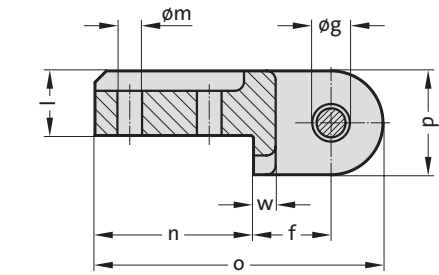
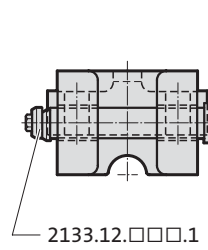

Note:

Order No for spare part bolt with safety ring: 2133.12.□□□.1

2133.12. Lifting flange with bolt with safety ring

Order No	max. carrying capacity (2 lifting flanges) [kg]*	a	b	c	d	f	g H13	h	l	m	n	o	p	w	d ₃
2133.12.016	1200	80	50	40	22.5	39	16	70	32	12.5	80	145	52	11	15.6
2133.12.021	2000	90	60	40	27.5	42	21	79	36	16.5	90	160	56	13	20.6
2133.12.026	4000	100	65	65	32.5	60	26	90	50	21	120	215	70	20	25.6

*The maximum permissible load capacity is to be calculated such that two lifting flanges one their own are capable of carrying or turning the tool.



Lifting flange with bolt with safety ring

2133.12.

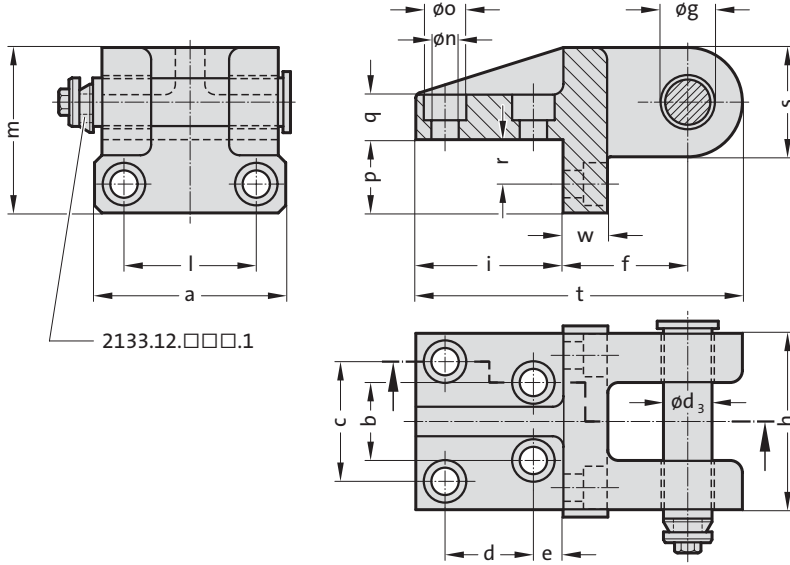

Note:

Order No for spare part bolt with safety ring: 2133.12.□□□.1

2133.12. Lifting flange with bolt with safety ring

Order No	max. carrying capacity (2 lifting flanges) [kg]*	a	b	c	d	e	f	g H13	h	i	l	m	n	o	p	q	r	s	t	w	d ₃
2133.12.034	8000	135	56	84	60	20	85	34	125	100	96	111	18	28	50	30	30	72	221	30	33
2133.12.044	14000	180	80	110	70	30	100	44	160	125	130	140	22	36	60	40	35	90	270	40	43

*The maximum permissible load capacity is to be calculated such that two lifting flanges one their own are capable of carrying or turning the tool.



2133.13.

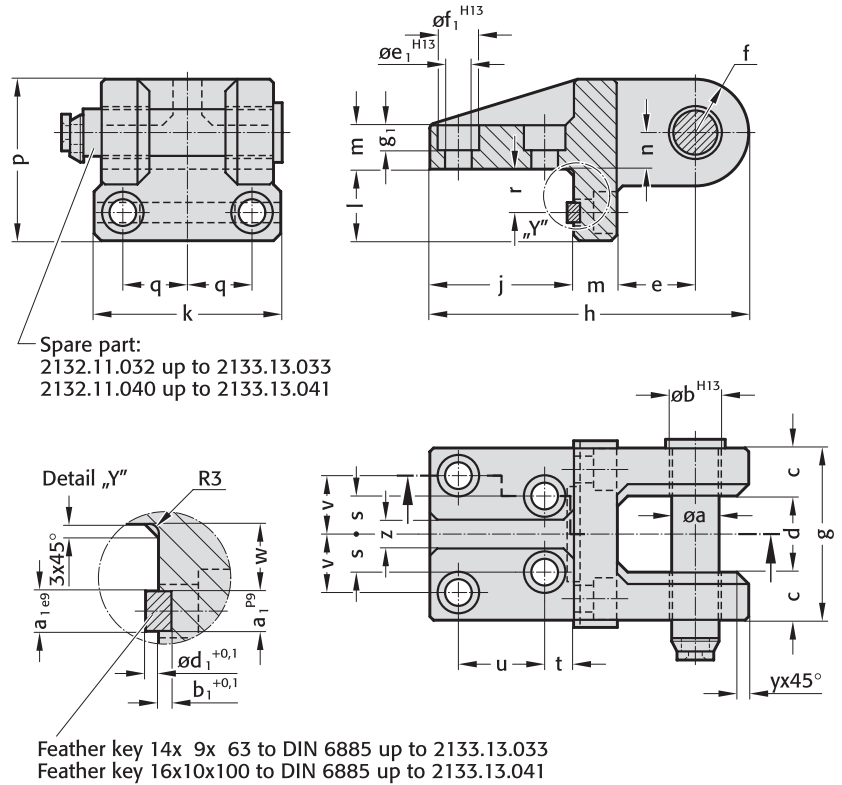

Note:

Order No for spare part bolt with safety ring:
2132.11.032 for 2133.13.033
2132.11.040 for 2133.13.041

Feather key to DIN 6885:
14x9x63 up to 2133.13.033
16x10x100 up to 2133.13.041

2133.13. Lifting flange with bolt with safety ring, with feather key, to CNOMO Standard

Order No	max. carrying capacity (2 lifting flanges) [kg]*																													
		a	b	c	d	e	f	g	h	j	k	l	m	n	p	q	r	s	t	u	v	w	y	z	a ₁	b ₁	d ₁	e ₁	f ₁	g ₁
2133.13.033	8000	32	33	35	55	55	36	125	221	100	135	50	30	25	111	48	30	28	20	60	42	24	10	20	14	4.5	4.5	18	28	17
2133.13.041	12600	40	41	50	60	60	45	160	270	125	180	60	40	35	140	65	35	40	30	70	55	27	12.5	25	16	5	5	22	36	21

*The maximum permissible load capacity is to be calculated such that two lifting flanges one their own are capable of carrying or turning the tool.

Lifting flange with bolt with safety ring, with feather key, to BMW

2133.15.

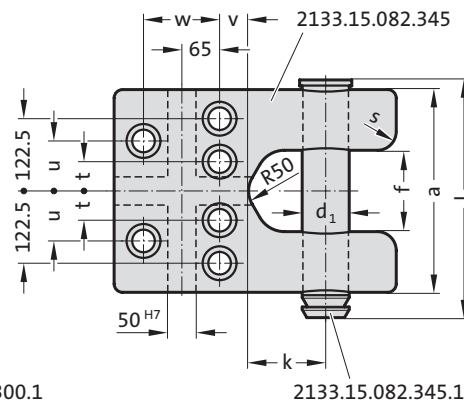
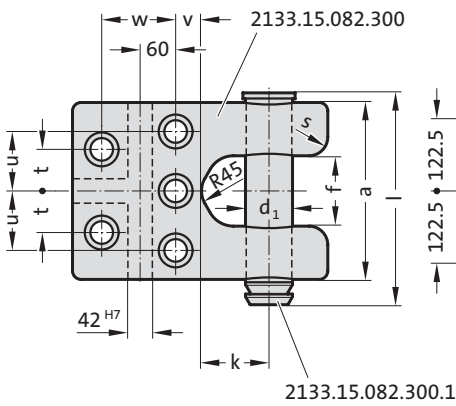
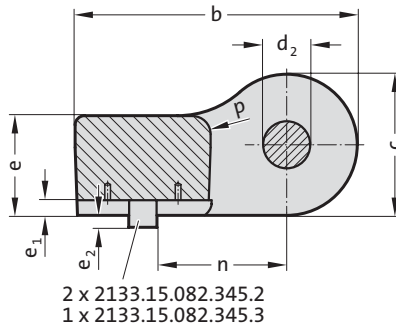
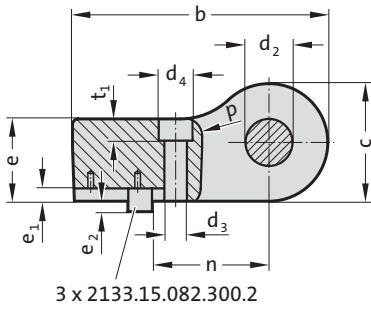

Note:

Order number of spare part for bolt with safety ring:
2133.15.082.□□□.1

Order number of spare part for feather key:
3x 2133.15.082.300.2 for 2133.15.082.300

2x 2133.15.082.345.2 and 1x 2133.15.082.345.3 for 2133.15.082.345

Order number of lifting flange with bolt and feather key including mounting screws according to BMW norm:
2133.15.0.082.□□□

2133.15. Lifting flange with bolt with safety ring, with feather key, to BMW

Order No	max. carrying capacity (2 lifting flanges) [kg]*																	Socket head cap screw DIN EN ISO 4762					
		d ₁	d ₂	a	b	c	e	f	k	l	n	p	s	t	u	v	w		d ₃	d ₄	t ₁	e ₁	e ₂
2133.15.082.300	50000	80	82	300	435	200	140	120	115	360	199	30	30	70	100	45	125	39	58	37	21	19	M36x160
2133.15.082.345	63000	80	82	345	480	240	170	135	130	405	220	30	30	50	85	50	130	39	58	37	26	22	M36x200

*The maximum permissible load capacity is to be calculated such that two lifting flanges one their own are capable of carrying or turning the tool.

Die lifting bolt with safety ring, VDI 3366



2132.10.

Mounting example

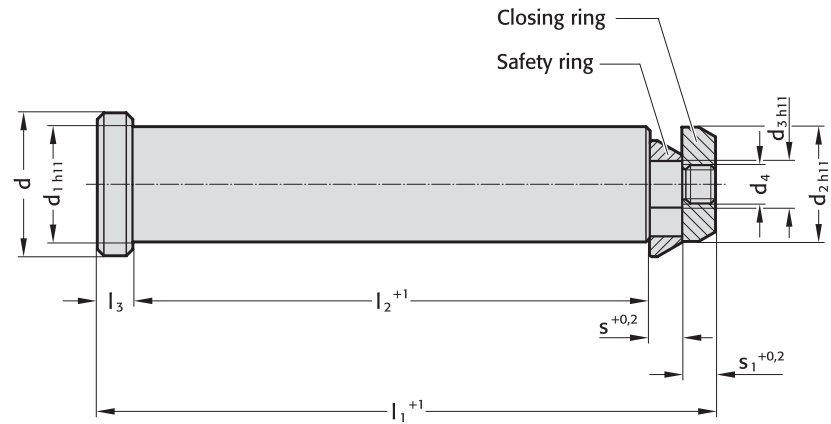
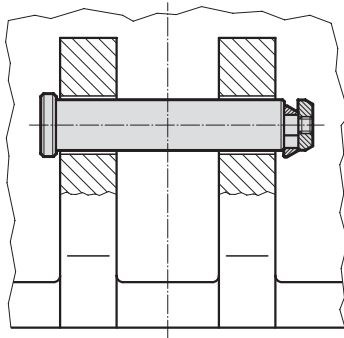

Note:

It is important to ensure that there is safety clearance on both outer sides of the cast cheeks and that there is room for installation on one side.

The lifting bolt must always be introduced from the outside of the tool towards the middle.

2132.10. Die lifting bolt with safety ring, VDI 3366

Order No	max. carrying capacity (2 die lifting bolts) [kg]*	d	d ₁	d ₂	d ₃	d ₄	l ₁	l ₂	l ₃	s	s ₁
2132.10.032	6400	40	32	32	13	M10	175	145	10	10	10
2132.10.040	10000	50	40	40	16	M12	225	188	10	14	13
2132.10.050	16000	60	50	50	24	M20	273	230	11	16	16
2132.10.063	25000	75	63	63	30	M24	347	295	14	18	20
2132.10.076	63000	95	76	76	40	M36	422	360	15	20	27

*The maximum permissible load capacity is to be calculated such that two bolts on their own are capable of carrying or turning the tool.

Die lifting bolt with safety ring and spring, to VW standard



2132.10.55.

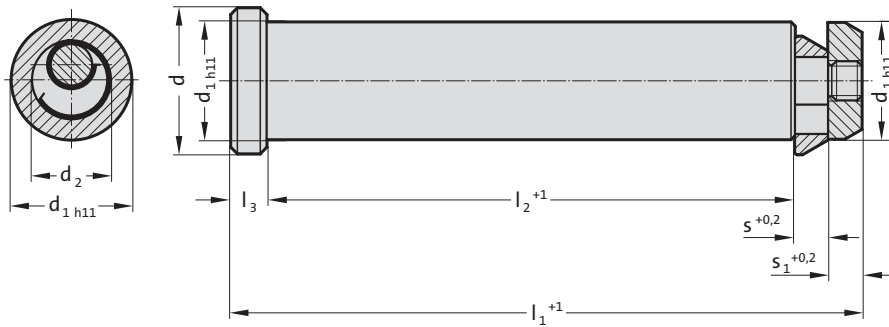

Mounting example

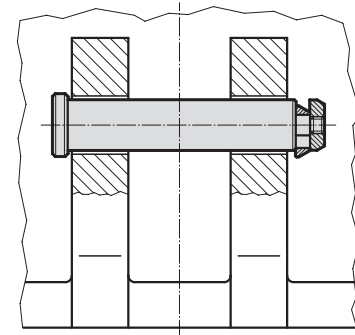

Note:

It is important to ensure that there is safety clearance on both outer sides of the cast cheeks and that there is room for installation on one side.

The lifting bolt must always be introduced from the outside of the tool towards the middle.

2132.10.55. Die lifting bolt with safety ring and spring, to VW standard

Order No	max. carrying capacity (2 die lifting bolts) [kg]*	d	d ₁	d ₂	l ₁	l ₂	l ₃	s	s ₁
2132.10.55.032	6400	40	32	21	175	145	10	10	10
2132.10.55.040	10000	50	40	28	225	188	10	14	13
2132.10.55.050	16000	60	50	36	273	230	11	16	16
2132.10.55.063	25000	75	63	45	347	295	14	18	20
2132.10.55.076	63000	95	76	56	422	360	15	20	27

*The maximum permissible load capacity is to be calculated such that two bolts on their own are capable of carrying or turning the tool.

Die lifting bolt with safety ring and spring, CNOMO Standard



2132.11.

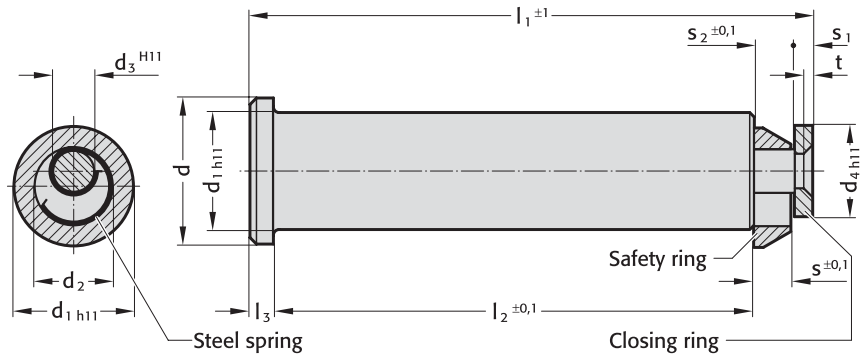

Mounting example

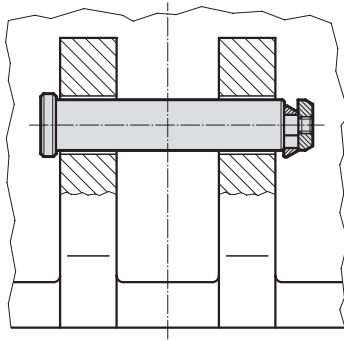

Note:

It is important to ensure that there is safety clearance on both outer sides of the cast cheeks and that there is room for installation on one side.

The lifting bolt must always be introduced from the outside of the tool towards the middle.



2132.11. Die lifting bolt with safety ring and spring, CNOMO Standard

Order No	max. carrying capacity (2 die lifting bolts) [kg]*	d	d ₁	d ₂	d ₃	d ₄	l ₁	l ₂	l ₃	s	s ₁	s ₂	t
2132.11.032	12000	40	32	22	12	25	154	132	6	10	5	11	2.5
2132.11.040	18000	50	40	28	16	32	197.75	170	8	12.5	6	13.75	3
2132.11.050	28000	63	50	36	20	40	247.6	212	10	16	8	17.6	4
2132.11.063	45000	80	63	45	25	50	309	265	12	20	10	22	5

*The maximum permissible load capacity is to be calculated such that two bolts on their own are capable of carrying or turning the tool.



Bush for die lifting bolt

2132.10.03. .1

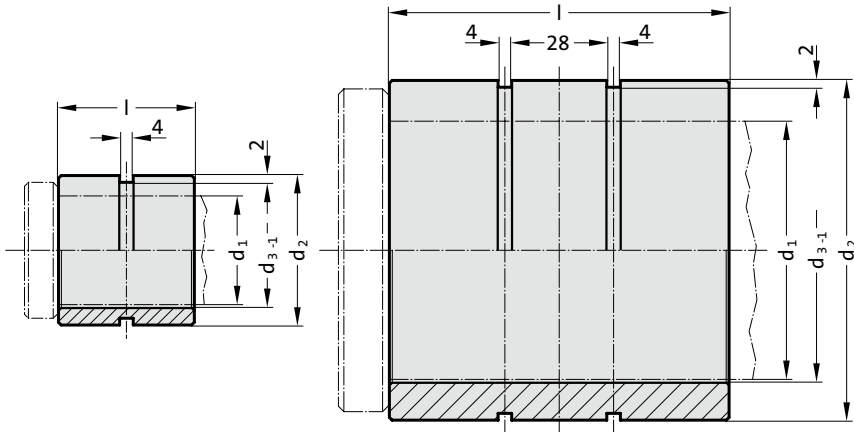

Mounting example

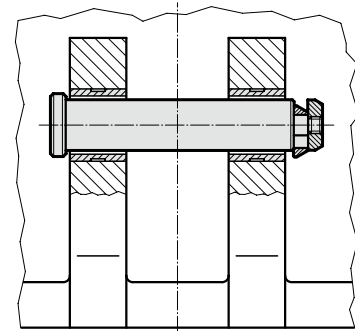

Description:

Bush for casting-in, for lifting bolts 2132.10./11.

Material:

1.0308 (E235)

2132.10.03. .1 Bush for di

Order No	d_1	d_2	d_3	l	Number of grooves
2132.10.03.032.1.1	32	44	34	40	1
2132.10.03.040.2.1	40	52	42	50	1
2132.10.03.050.3.1	50	62	52	60	1
2132.10.03.063.4.1	63	75	65	80	1
2132.10.03.076.5.1	76	100	78	100	2
2132.10.03.076.6.1	76	105	78	100	2

Die lifting bolt with safety ring, for lifting flange 2133.12.



2133.12. .1

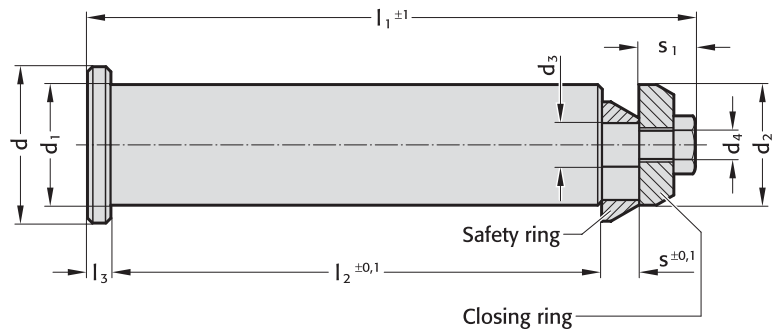

Mounting example

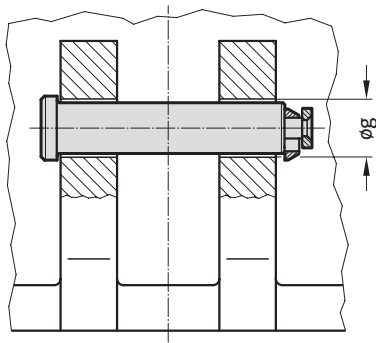

Note:

It is important to ensure that there is safety clearance on both outer sides of the cast cheeks and that there is room for installation on one side.

The lifting bolt must always be introduced from the outside of the tool towards the middle.

2133.12. .1 Die lifting bolt with safety ring, for lifting flange 2133.12.

Order No	max. carrying capacity (2 die lifting bolts) [kg]*	g	d	d ₁	d ₂	d ₃	d ₄	l ₁	l ₂	l ₃	s	s ₁
2133.12.016.1	1200	16	25	15.6	15.6	6	M5	102.5	77	6	8	11.5
2133.12.021.1	2000	21	30	20.6	20.6	7	M6	113.5	86	6	8	13.5
2133.12.026.1	4000	26	35	25.6	25.6	9	M6	128.5	100	6	9	13.5
2133.12.034.1	8000	34	43	33	33	12	M8	166.5	135	6	10	15.5
2133.12.044.1	14000	44	53	43	43	16	M12	210.5	175	8	12	20.5

*The maximum permissible load capacity is to be calculated such that two bolts on their own are capable of carrying or turning the tool.

Clamp, forked shape, DIN 6315-B

Clamping claw, goose-neck shape



2140.17.

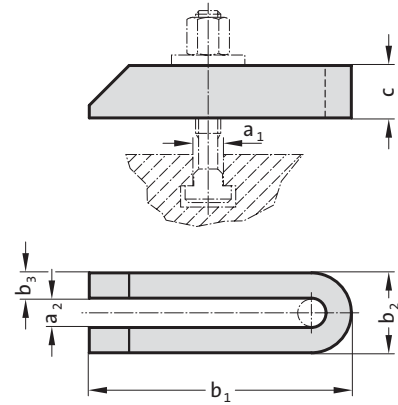

Material:

Heat-treated steel, painted

Note:

Holding and contact surfaces are plane-parallel. High clamping forces can be achieved by using high-strength screws conforming to DIN 787. The dimensions of the holding strap should be matched to the strength of the bolts.

Supplied without clamping bolt, suitable clamping bolts: 2140.30.

2140.17. Clamp, forked shape, DIN 6315-B

Order No	a ₁	a ₂	b ₁	b ₂	b ₃	c
2140.17.09.080	8	9	80	25	8	15
2140.17.11.100	10	11	100	31	10	20
2140.17.14.125	12 o. 14	14	125	38	12	25
2140.17.14.160	12 o. 14	14	160	38	12	25
2140.17.14.200	12 o. 14	14	200	38	12	25
2140.17.18.160	16 o. 18	18	160	48	15	30
2140.17.18.200	16 o. 18	18	200	48	15	30
2140.17.18.250	16 o. 18	18	250	48	15	40
2140.17.22.200	20 o. 22	22	200	52	15	40
2140.17.22.250	20 o. 22	22	250	62	20	40
2140.17.22.315	20 o. 22	22	315	62	20	40
2140.17.26.200	24	26	200	66	20	40
2140.17.26.250	24	26	250	66	20	40
2140.17.26.315	24	26	315	66	20	40

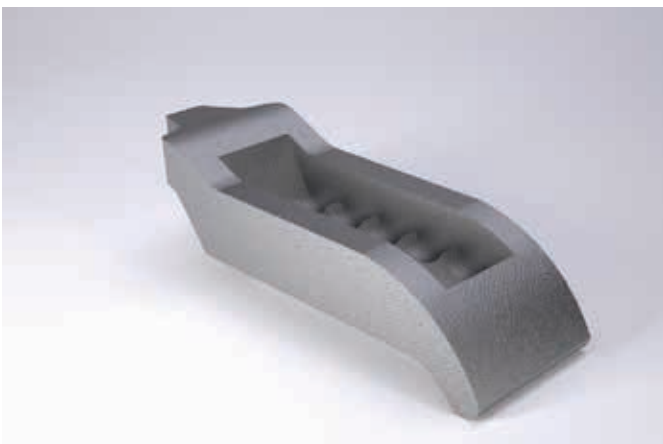

2140.15.

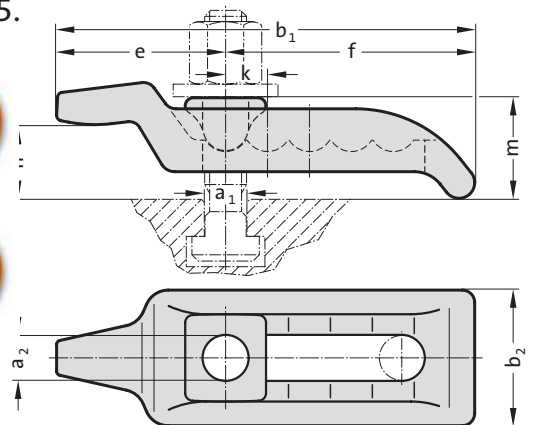

Material:

Steel, forged and heat-treated, galvanized and yellow passivated

Note:

Clamping claws quickly span very different clamping heights without the need for additional supports and take up very little space on the machine table. They are designed for maximum loads and are particularly suitable for clamping cutting and punching tools.

Supplied without clamping bolt, suitable clamping bolts: 2140.30.

2140.15. Clamping claw, goose-neck shape

Order No	a ₁	a ₂	b ₁	b ₂	e	f	k	m	Clamping height h
2140.15.22	20 o. 22	22	200	66	88	112	20	60	25 - 50
2140.15.26	24 o. 26	26	232	76	97	135	24	70	30 - 70
2140.15.32	36	32	263	90	107	156	28	80	40 - 75

Clamping claw, infinitely variable

2140.13.

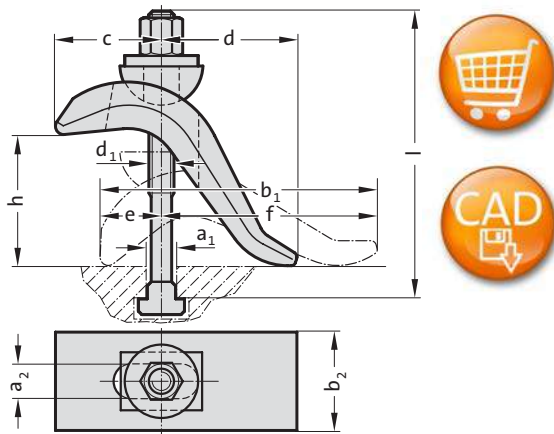

2140.13. Clamping claw, infinitely variable

Order No	a ₁	a ₂	b ₁	b ₂	c	d	e	f	h*	Clamping bolt
										d ₁ x a ₁ x l
2140.13.12.17	12	17	140	50	55	60	30	110	0-50	M12x12x125
2140.13.14.17	14	17	140	50	55	60	30	110	0-50	M12x14x125
2140.13.16.17	16	17	140	50	55	60	30	110	0-75	M16x16x160
2140.13.18.17	18	17	140	50	55	60	30	110	0-75	M16x18x160
2140.13.16.21	16	21	175	60	70	80	40	135	0-65	M16x16x160
2140.13.18.21	18	21	175	60	70	80	40	135	0-65	M16x18x160
2140.13.22.21	22	21	175	60	70	80	40	135	0-85	M20x22x200

*Clamping height

Material:

Steel, forged and head-treated, tempered in burnishing clay.

Note:

Clamping claws quickly span very different clamping heights without the need for additional supports and take up very little space on the machine table. They are designed for maximum loads and are particularly suitable for clamping cutting and punching tools.

Supplied with clamping bolt,
suitable clamping bolts: 2140.30.

2140.14.

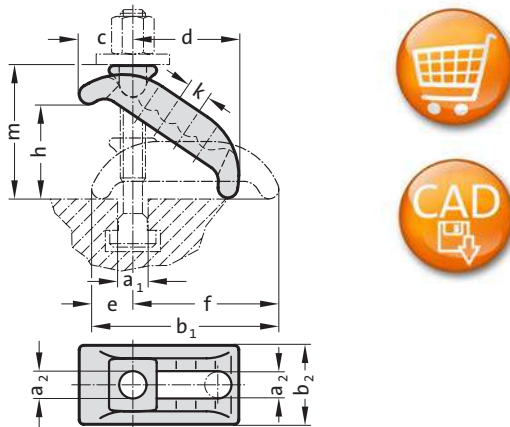

2140.14. Clamping claw, infinitely variable

Order No	a ₁	a ₂	b ₁	b ₂	c	d	e	f	k	m	h _{max}
2140.14.13	12	o. 14	13	88	38	28	48	23	68	14	35
2140.14.18	16	o. 18	18	130	56	38	74	29	101	18	55
2140.14.22	20	o. 22	22	140	66	46	80	32	112	20	65
2140.14.26	24	o. 28	26	174	76	52	100	39	135	24	75
2140.14.32	36		32	200	90	61	110	44	156	28	80

Material:

Steel, forged and heat-treated,
galvanised and yellow passivated

Note:

Clamping claws quickly span very different clamping heights without the need for additional supports and take up very little space on the machine table. They are designed for maximum loads and are particularly suitable for clamping cutting and punching tools.

Supplied without clamping bolt,
suitable clamping bolts: 2140.30.

Clamp, straight, DIN 6314

Clamp, straight, with setscrew

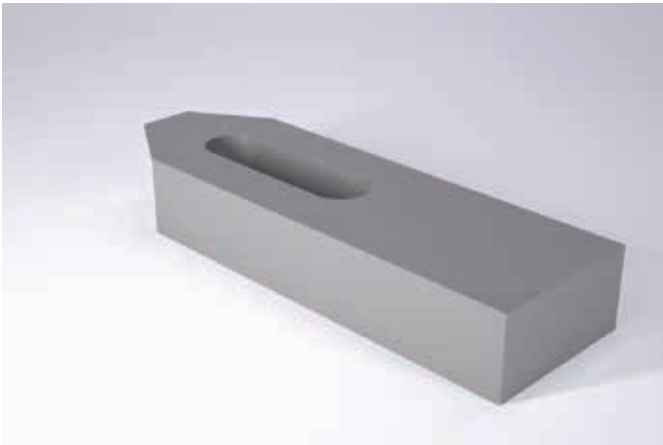

2140.16.

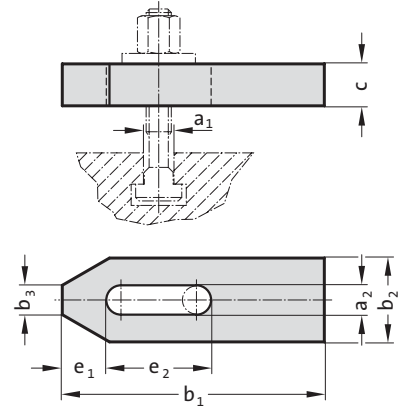

Material:

Heat-treated steel, painted

Note:

Holding and contact surfaces are plane-parallel. High clamping forces can be achieved by using high-strength screws conforming to DIN 787. The dimensions of the holding strap should be matched to the strength of the bolts.

Supplied without clamping bolt, suitable clamping bolts: 2140.30.

2140.16.26.250: c = 35 mm, does not conform to DIN

2140.16. Clamp, straight, DIN 6314

Order No	a ₁	a ₂	b ₁	b ₂	b ₃	c	e ₁	e ₂
2140.16.09.060	8	9	60	25	10	12	13	22
2140.16.11.080	10	11	80	30	12	15	15	30
2140.16.14.100	12 o. 14	14	100	40	14	20	21	40
2140.16.14.125	12 o. 14	14	125	40	14	20	21	50
2140.16.18.125	16 o. 18	18	125	50	18	25	26	45
2140.16.18.160	16 o. 18	18	160	50	18	25	26	65
2140.16.22.160	20 o. 22	22	160	60	22	30	30	60
2140.16.22.200	20 o. 22	22	200	60	22	30	30	80
2140.16.26.200	24	26	200	70	26	30	35	80
2140.16.26.250	24	26	250	70	26	35	35	105



2140.10.

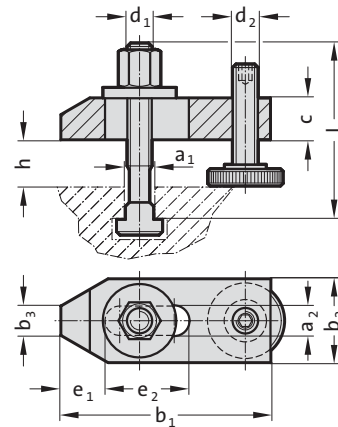

Material:

Heat-treated steel, painted

Note:

Supplied with setscrew and clamping bolt for T grooves conforming to DIN 787 8.8 with nut and washer.

2140.10. Clamp, straight, with setscrew

Order No	a ₁	a ₂	b ₁	b ₂	b ₃	c	d _{1,2}	e ₁	e ₂	h*	Clamping bolt d ₁ x a ₁ x l
2140.10.10	10	11	80	30	12	15	M10	15	30	8 - 32	M10x10x80
2140.10.12	12	14	100	40	14	20	M12	21	40	10 - 40	M12x12x100
2140.10.14	14	14	100	40	14	20	M12	21	40	10 - 38	M12x14x100
2140.10.16	16	18	125	50	18	25	M16	26	45	13 - 49	M16x16x125
2140.10.18	18	18	125	50	18	25	M16	26	45	13 - 46	M16x18x125
2140.10.20	20	22	160	60	22	30	M20	30	60	16 - 65	M20x20x160
2140.10.22	22	22	160	60	22	30	M20	30	60	16 - 65	M20x22x160

*Clamping height depends on the groove depth

Clamp, goose neck shape, DIN 6316

Clamp, goose neck shape, with setscrew

2140.18.

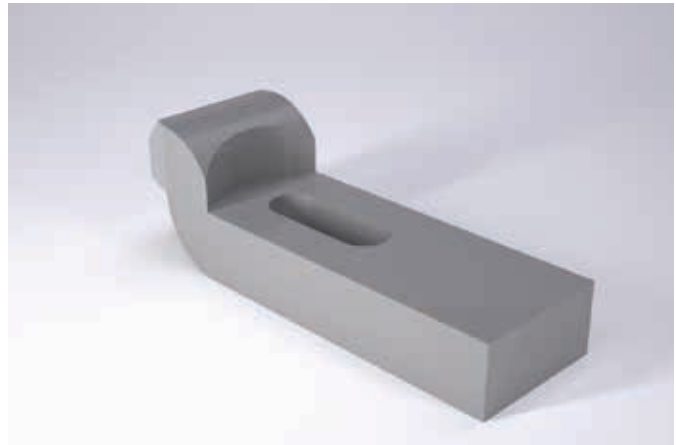
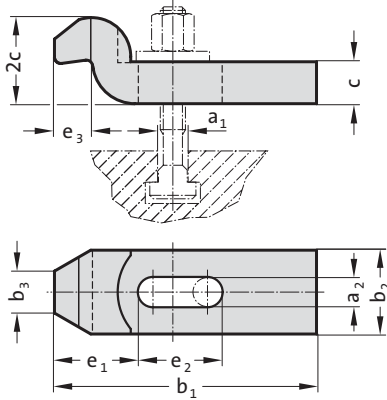

2140.18. Clamp, goose neck shape, DIN 6316

Order No	a ₁	a ₂	b ₁	b ₂	b ₃	c	e ₁	e ₂	e ₃
2140.18.09.080	8	9	80	25	12	12	25	25	9
2140.18.11.100	10	11	100	30	15	15	32	32	12
2140.18.14.125	12 o. 14	14	125	40	20	20	40	40	16
2140.18.18.125	16 o. 18	18	125	50	25	25	49	49	20
2140.18.18.160	16 o. 18	18	160	50	25	25	49	50	20
2140.18.22.160	20 o. 22	22	160	60	30	30	55	55	24
2140.18.22.200	20 o. 22	22	200	60	30	30	55	70	24
2140.18.26.200	24	26	200	70	35	30	72	60	28
2140.18.26.250	24	26	250	70	35	35	72	80	28

Material:

Heat-treated steel, painted

Note:

Holding and contact surfaces are plane-parallel. High clamping forces can be achieved by using high-strength screws conforming to DIN 787. The dimensions of the holding strap should be matched to the strength of the bolts.

Supplied without clamping bolt, suitable clamping bolts: 2140.30.

2140.18.26.250: c = 35 mm, does not conform to DIN

2140.11.

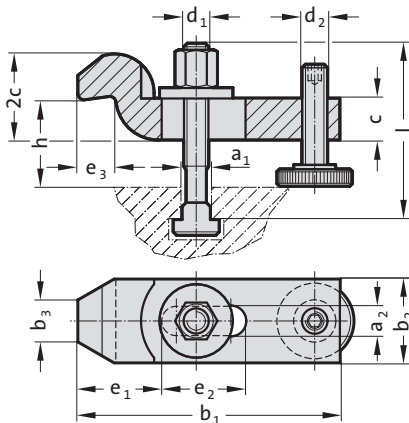

2140.11. Clamp, goose neck shape, with setscrew

Order No	a ₁	a ₂	b ₁	b ₂	b ₃ ,c	d _{1,2}	e ₁	e ₂	e ₃	h*	Clamping bolt d ₁ x a ₁ x l
2140.11.10	10	11	100	30	15	M10	32	32	12	22 - 46	M10x10x80
2140.11.12	12	14	125	40	20	M12	40	40	16	28 - 58	M12x12x100
2140.11.14	14	14	125	40	20	M12	40	40	16	28 - 56	M12x14x100
2140.11.16	16	18	160	50	25	M16	49	50	20	36 - 72	M16x16x125
2140.11.18	18	18	160	50	25	M16	49	50	20	36 - 69	M16x18x125
2140.11.20	20	22	200	60	30	M20	55	70	24	43 - 92	M20x20x160
2140.11.22	22	22	200	60	30	M20	55	70	24	43 - 92	M20x22x160

*Clamping height depends on the groove depth

Material:

Heat-treated steel, painted

Note:

Supplied with setscrew and clamping bolt for T grooves conforming to DIN 787 8.8 with nut and washer.

Support, adjustable Stepped Block DIN 6318



2140.20.

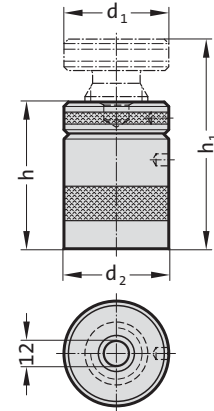

Material:

Heat-treated steel, painted

Note:

Centring hole diameter 12 mm. Spindle with self-locking trapezoidal thread and end lock.

2140.20. Support, adjustable

Order No	h	h ₁	d ₁	d ₂	F _{max} [daN]
2140.20.042	42	52	50	50	6000
2140.20.050	50	70	50	50	6000
2140.20.070	70	100	50	50	6000
2140.20.100	100	140	65	70	10000
2140.20.140	140	210	70	80	17000
2140.20.190	190	300	80	100	35000



2140.19.

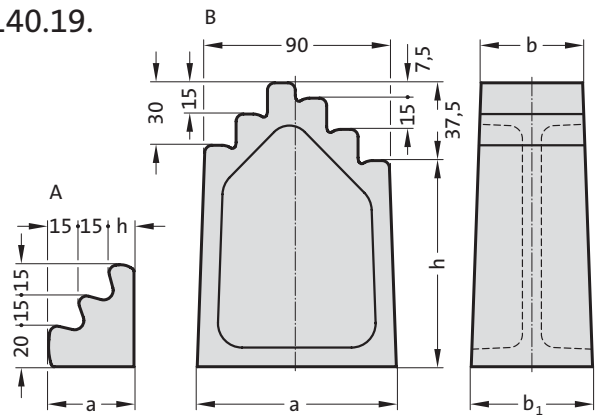

Material:

Engineering cast iron, painted.

Note:

Holding and contact surfaces are plane-parallel. High clamping forces can be achieved by using high-strength screws conforming to DIN 787. The dimensions of the holding strap should be matched to the strength of the bolts.

2140.19. Stepped Block DIN 6318

Order No	Ordering size	a	b	b ₁	h	Shape
2140.19.050.050	50	42.5	50	50	12.5	A
2140.19.095.050	95	95	50	55	57.5	B
2140.19.140.050	140	100	50	60	102.5	B
2140.19.185.050	185	105	50	65	147.5	B
2140.19.230.050	230	110	50	70	192.5	B
2140.19.275.050	275	115	50	75	237.5	B
2140.19.050.080	50	42.5	80	80	12.5	A
2140.19.095.080	95	95	80	85	57.5	B
2140.19.140.080	140	100	80	90	102.5	B

Set screw

Hexagon Nut DIN 6330 B

2140.02.

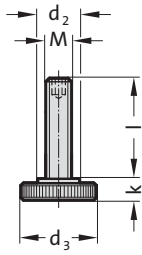

2140.02. Set screw

Material:
heat-treated, strength class 8.8

Order No	M	d ₂	d ₃	k	l
2140.02.10	M10	16	30	8	39
2140.02.12	M12	20	36	10	48
2140.02.16	M16	25	42	13	55
2140.02.20	M20	25	50	16	69
2140.02.24	M24	34	60	20	87

2140.32.

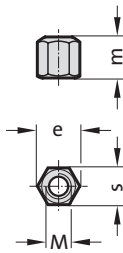

2140.32. Hexagon Nut DIN 6330 B

Material:
heat-treated, strength class 10.9

Order No	M	e	m	s
2140.32.08	M8	15	12	13
2140.32.10	M10	18.4	15	16
2140.32.12	M12	20.7	18	18
2140.32.14	M14	24.2	21	21
2140.32.16	M16	27.7	24	24
2140.32.18	M18	31.2	27	27
2140.32.20	M20	34.6	30	30
2140.32.22	M22	39.2	33	34
2140.32.24	M24	41.5	36	36
2140.32.30	M30	53.1	45	46

Note:
Use washers conforming to DIN 6340.

Hexagon nut with collar, DIN 6331 Washer DIN 6340



2140.33.

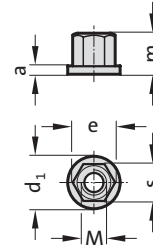

Material:
heat-treated, strength class 10.9

Execution:
turned and milled

Note:
Thread length 1,5 x M

2140.33. Hexagon nut with collar, DIN 6331

Order No	M	a	d ₁	e	m	s
2140.33.08	M8	3.5	18	15	12	13
2140.33.10	M10	4	22	18.4	15	16
2140.33.12	M12	4	25	20.7	18	18
2140.33.14	M14	4.5	28	24.2	21	21
2140.33.16	M16	5	31	27.7	24	24
2140.33.18	M18	5	34	31.2	27	27
2140.33.20	M20	6	37	34.6	30	30
2140.33.22	M22	6	40	39.2	33	34
2140.33.24	M24	6	45	41.5	36	36
2140.33.30	M30	6	58	53.1	45	46



2140.34.

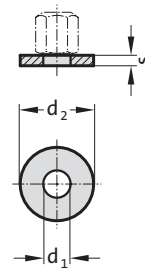

Material:
heat-treated, strength 1200–1400 N/mm²

2140.34. Washer DIN 6340

Order No	M	d ₁	d ₂	s
2140.34.08	M8	8.4	23	4
2140.34.10	M10	10.5	28	4
2140.34.12	M12	13	35	5
2140.34.14	M14	15	40	5
2140.34.16	M16	17	45	6
2140.34.18	M18	19	45	6
2140.34.20	M20	21	50	6
2140.34.22	M22	23	50	8
2140.34.24	M24	25	60	8
2140.34.30	M30	31	68	10

Screw for T-slot, DIN 787



2140.30.

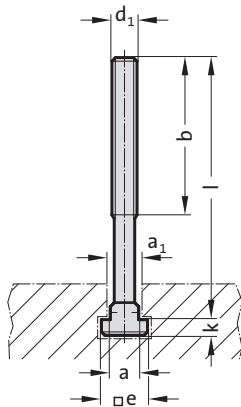

Material:

heat-treated,
M 8 – M12 to strength class 10.9
M14 – M30 to strength class 8.8

Execution:

forged, thread rolled, T-slot milled

2140.30. Screw for T-slot, DIN 787

Order No	a ₁	a	b	d ₁	e	k	l	Order No	a ₁	a	b	d ₁	e	k	l
2140.30.08.08.032	8	7.7	22	M8	13	6	32	2140.30.20.20.100	20	19.7	65	M20	32	12	100
2140.30.08.08.050	8	7.7	35	M8	13	6	50	2140.30.20.20.125	20	19.7	85	M20	32	12	125
2140.30.08.08.080	8	7.7	50	M8	13	6	80	2140.30.20.20.160	20	19.7	110	M20	32	12	160
2140.30.10.10.040	10	9.7	30	M10	15	6	40	2140.30.20.20.200	20	19.7	125	M20	32	12	200
2140.30.10.10.063	10	9.7	45	M10	15	6	63	2140.30.20.20.250	20	19.7	150	M20	32	12	250
2140.30.10.10.100	10	9.7	60	M10	15	6	100	2140.30.20.20.315	20	19.7	190	M20	32	12	315
2140.30.12.12.050	12	11.7	35	M12	18	7	50	2140.30.20.22.080	22	21.7	55	M20	35	14	80
2140.30.12.12.063	12	11.7	40	M12	18	7	63	2140.30.20.22.100	22	21.7	65	M20	35	14	100
2140.30.12.12.080	12	11.7	55	M12	18	7	80	2140.30.20.22.125	22	21.7	85	M20	35	14	125
2140.30.12.12.125	12	11.7	75	M12	18	7	125	2140.30.20.22.160	22	21.7	110	M20	35	14	160
2140.30.12.12.200	12	11.7	120	M12	18	7	200	2140.30.20.22.200	22	21.7	125	M20	35	14	200
2140.30.12.14.050	14	13.7	35	M12	22	8	50	2140.30.20.22.250	22	21.7	150	M20	35	14	250
2140.30.12.14.063	14	13.7	45	M12	22	8	63	2140.30.20.22.315	22	21.7	190	M20	35	14	315
2140.30.12.14.080	14	13.7	55	M12	22	8	80	2140.30.24.24.100	24	23.7	70	M24	40	16	100
2140.30.12.14.125	14	13.7	75	M12	22	8	125	2140.30.24.24.125	24	23.7	85	M24	40	16	125
2140.30.12.14.200	14	13.7	120	M12	22	8	200	2140.30.24.24.160	24	23.7	110	M24	40	16	160
2140.30.14.16.063	16	15.7	45	M14	25	9	63	2140.30.24.24.200	24	23.7	125	M24	40	16	200
2140.30.14.16.100	16	15.7	65	M14	25	9	100	2140.30.24.24.250	24	23.7	150	M24	40	16	250
2140.30.14.16.160	16	15.7	125	M14	25	9	160	2140.30.24.24.315	24	23.7	190	M24	40	16	315
2140.30.14.16.250	16	15.7	150	M14	25	9	250	2140.30.24.24.400	24	23.7	240	M24	40	16	400
2140.30.16.16.063	16	15.7	45	M16	25	9	63	2140.30.24.28.100	28	27.7	70	M24	44	18	100
2140.30.16.16.080	16	15.7	55	M16	25	9	80	2140.30.24.28.125	28	27.7	85	M24	44	18	125
2140.30.16.16.100	16	15.7	65	M16	25	9	100	2140.30.24.28.160	28	27.7	110	M24	44	18	160
2140.30.16.16.160	16	15.7	100	M16	25	9	160	2140.30.24.28.200	28	27.7	125	M24	44	18	200
2140.30.16.16.200	16	15.7	125	M16	25	9	200	2140.30.24.28.250	28	27.7	150	M24	44	18	250
2140.30.16.16.250	16	15.7	150	M16	25	9	250	2140.30.24.28.315	28	27.7	190	M24	44	18	315
2140.30.16.18.063	18	17.7	45	M16	28	10	63	2140.30.24.28.400	28	27.7	240	M24	44	18	400
2140.30.16.18.080	18	17.7	55	M16	28	10	80	2140.30.30.36.125	36	35.6	80	M30	54	22	125
2140.30.16.18.100	18	17.7	65	M16	28	10	100	2140.30.30.36.160	36	35.6	110	M30	54	22	160
2140.30.16.18.160	18	17.7	100	M16	28	10	160	2140.30.30.36.200	36	35.6	135	M30	54	22	200
2140.30.16.18.200	18	17.7	125	M16	28	10	200	2140.30.30.36.250	36	35.6	150	M30	54	22	250
2140.30.16.18.250	18	17.7	150	M16	28	10	250	2140.30.30.36.315	36	35.6	200	M30	54	22	315
2140.30.20.20.080	20	19.7	55	M20	32	12	80	2140.30.30.36.500	36	35.6	300	M30	54	22	500

Hexagon socket head cap screw, DIN EN ISO 4762 - Strength class 8.8



2192.10.

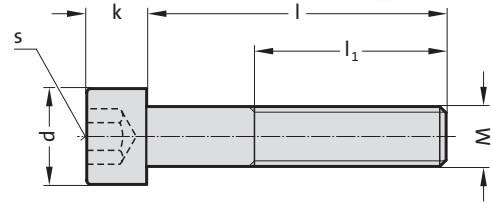

2192.10. Hexagon socket head cap screw, DIN EN ISO 4762 - Strength class 8.8

Order No	M	l	l ₁	d	k	s	Order No	M	l	l ₁	d	k	s
2192.10.04.012	M4	12	10	7	4	3	2192.10.10.050	M10	50	32	16	10	8
2192.10.04.016	M4	16	14	7	4	3	2192.10.10.060	M10	60	32	16	10	8
2192.10.04.020	M4	20	18	7	4	3	2192.10.12.025	M12	25	20	18	12	10
2192.10.04.025	M4	25	23	7	4	3	2192.10.12.030	M12	30	25	18	12	10
2192.10.05.020	M5	20	18	8.5	5	4	2192.10.12.035	M12	35	30	18	12	10
2192.10.05.025	M5	25	23	8.5	5	4	2192.10.12.040	M12	40	35	18	12	10
2192.10.05.030	M5	30	22	8.5	5	4	2192.10.12.045	M12	45	40	18	12	10
2192.10.06.016	M6	16	13	10	6	5	2192.10.12.050	M12	50	45	18	12	10
2192.10.06.020	M6	20	17	10	6	5	2192.10.12.070	M12	70	36	18	12	10
2192.10.06.025	M6	25	22	10	6	5	2192.10.12.080	M12	80	36	18	12	10
2192.10.06.030	M6	30	27	10	6	5	2192.10.16.030	M16	30	24	24	16	14
2192.10.06.035	M6	35	24	10	6	5	2192.10.16.035	M16	35	29	24	16	14
2192.10.06.040	M6	40	24	10	6	5	2192.10.16.040	M16	40	34	24	16	14
2192.10.06.045	M6	45	24	10	6	5	2192.10.16.045	M16	45	39	24	16	14
2192.10.06.050	M6	50	24	10	6	5	2192.10.16.050	M16	50	44	24	16	14
2192.10.06.055	M6	55	24	10	6	5	2192.10.16.055	M16	55	49	24	16	14
2192.10.06.060	M6	60	24	10	6	5	2192.10.16.060	M16	60	54	24	16	14
2192.10.06.070	M6	70	24	10	6	5	2192.10.16.100	M16	100	44	24	16	14
2192.10.06.080	M6	80	24	10	6	5	2192.10.20.050	M20	50	42	30	20	17
2192.10.06.090	M6	90	24	10	6	5	2192.10.20.060	M20	60	52	30	20	17
2192.10.08.016	M8	16	12	13	8	6	2192.10.20.070	M20	70	62	30	20	17
2192.10.08.020	M8	20	16	13	8	6	2192.10.20.090	M20	90	52	30	20	17
2192.10.08.025	M8	25	21	13	8	6	2192.10.20.120	M20	120	52	30	20	17
2192.10.08.030	M8	30	26	13	8	6	2192.10.24.060	M24	60	51	36	24	19
2192.10.08.035	M8	35	31	13	8	6	2192.10.24.070	M24	70	61	36	24	19
2192.10.08.040	M8	40	28	13	8	6	2192.10.24.080	M24	80	71	36	24	19
2192.10.08.045	M8	45	28	13	8	6	2192.10.24.100	M24	100	60	36	24	19
2192.10.08.050	M8	50	28	13	8	6	2192.10.24.120	M24	120	60	36	24	19
2192.10.08.060	M8	60	28	13	8	6	2192.10.24.140	M24	140	60	36	24	19
2192.10.10.016	M10	16	11	16	10	8	2192.10.30.140	M30	140	72	45	30	22
2192.10.10.020	M10	20	15	16	10	8	2192.10.36.120	M36	120	84	54	36	27
2192.10.10.025	M10	25	20	16	10	8	2192.10.36.160	M36	160	84	54	36	27
2192.10.10.030	M10	30	25	16	10	8	2192.10.36.180	M36	180	84	54	36	27
2192.10.10.035	M10	35	30	16	10	8	2192.10.36.200	M36	200	84	54	36	27
2192.10.10.040	M10	40	35	16	10	8							

Hexagon socket head cap screw, DIN EN ISO 4762 - Strength class 12.9

2192.12.

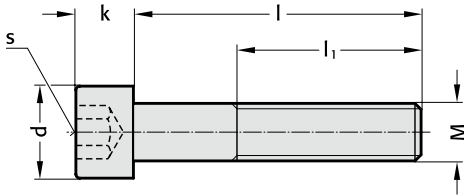

2192.12. Hexagon socket head cap screw, DIN EN ISO 4762 - Strength class 12.9

Order No	M	l	l ₁	d	k	s	Order No	M	l	l ₁	d	k	s	Order No	M	l	l ₁	d	k	s
2192.12.03.008	M3	8	6	5.5	3	2.5	2192.12.08.100	M8	100	28	13	8	6	2192.12.16.070	M16	70	44	24	16	14
2192.12.04.010	M4	10	8	7	4	3	2192.12.08.110	M8	110	28	13	8	6	2192.12.16.080	M16	80	44	24	16	14
2192.12.05.030	M5	30	22	8.5	5	4	2192.12.08.120	M8	120	28	13	8	6	2192.12.16.090	M16	90	44	24	16	14
2192.12.05.035	M5	35	22	8.5	5	4	2192.12.10.030	M10	30	25	16	10	8	2192.12.16.100	M16	100	44	24	16	14
2192.12.05.040	M5	40	22	8.5	5	4	2192.12.10.035	M10	35	30	16	10	8	2192.12.16.110	M16	110	44	24	16	14
2192.12.05.045	M5	45	22	8.5	5	4	2192.12.10.040	M10	40	35	16	10	8	2192.12.16.120	M16	120	44	24	16	14
2192.12.05.050	M5	50	22	8.5	5	4	2192.12.10.045	M10	45	32	16	10	8	2192.12.16.130	M16	130	44	24	16	14
2192.12.05.055	M5	55	22	8.5	5	4	2192.12.10.050	M10	50	32	16	10	8	2192.12.16.140	M16	140	44	24	16	14
2192.12.05.060	M5	60	22	8.5	5	4	2192.12.10.055	M10	55	32	16	10	8	2192.12.16.150	M16	150	44	24	16	14
2192.12.05.065	M5	65	22	8.5	5	4	2192.12.10.060	M10	60	32	16	10	8	2192.12.16.160	M16	160	44	24	16	14
2192.12.05.070	M5	70	22	8.5	5	4	2192.12.10.065	M10	65	32	16	10	8	2192.12.16.180	M16	180	44	24	16	14
2192.12.05.075	M5	75	22	8.5	5	4	2192.12.10.070	M10	70	32	16	10	8	2192.12.16.200	M16	200	44	24	16	14
2192.12.05.080	M5	80	22	8.5	5	4	2192.12.10.075	M10	75	32	16	10	8	2192.12.16.220	M16	220	44	24	16	14
2192.12.06.010	M6	10	7	10	6	5	2192.12.10.080	M10	80	32	16	10	8	2192.12.16.240	M16	240	44	24	16	14
2192.12.06.020	M6	20	17	10	6	5	2192.12.10.090	M10	90	32	16	10	8	2192.12.16.260	M16	260	44	24	16	14
2192.12.06.025	M6	25	22	10	6	5	2192.12.10.100	M10	100	32	16	10	8	2192.12.16.280	M16	280	44	24	16	14
2192.12.06.030	M6	30	27	10	6	5	2192.12.10.110	M10	110	32	16	10	8	2192.12.16.300	M16	300	44	24	16	14
2192.12.06.035	M6	35	24	10	6	5	2192.12.10.120	M10	120	32	16	10	8	2192.12.20.100	M20	100	52	30	20	17
2192.12.06.040	M6	40	24	10	6	5	2192.12.10.130	M10	130	32	16	10	8	2192.12.20.110	M20	110	52	30	20	17
2192.12.06.045	M6	45	24	10	6	5	2192.12.10.150	M10	150	32	16	10	8	2192.12.20.120	M20	120	52	30	20	17
2192.12.06.050	M6	50	24	10	6	5	2192.12.10.180	M10	180	32	16	10	8	2192.12.20.130	M20	130	52	30	20	17
2192.12.06.055	M6	55	24	10	6	5	2192.12.10.220	M10	220	32	16	10	8	2192.12.20.140	M20	140	52	30	20	17
2192.12.06.060	M6	60	24	10	6	5	2192.12.12.040	M12	40	35	18	12	10	2192.12.20.150	M20	150	52	30	20	17
2192.12.06.070	M6	70	24	10	6	5	2192.12.12.045	M12	45	40	18	12	10	2192.12.20.160	M20	160	52	30	20	17
2192.12.06.080	M6	80	24	10	6	5	2192.12.12.050	M12	50	45	18	12	10	2192.12.20.180	M20	180	52	30	20	17
2192.12.06.085	M6	85	24	10	6	5	2192.12.12.055	M12	55	36	18	12	10	2192.12.20.190	M20	190	52	30	20	17
2192.12.06.090	M6	90	24	10	6	5	2192.12.12.060	M12	60	36	18	12	10	2192.12.20.200	M20	200	52	30	20	17
2192.12.06.100	M6	100	24	10	6	5	2192.12.12.070	M12	70	36	18	12	10	2192.12.20.220	M20	220	52	30	20	17
2192.12.06.160	M6	160	24	10	6	5	2192.12.12.080	M12	80	36	18	12	10	2192.12.20.230	M20	230	52	30	20	17
2192.12.06.200	M6	200	24	10	6	5	2192.12.12.090	M12	90	36	18	12	10	2192.12.20.240	M20	240	52	30	20	17
2192.12.08.016	M8	16	12	13	8	6	2192.12.12.100	M12	100	36	18	12	10	2192.12.20.260	M20	260	52	30	20	17
2192.12.08.030	M8	30	26	13	8	6	2192.12.12.110	M12	110	36	18	12	10	2192.12.20.280	M20	280	52	30	20	17
2192.12.08.035	M8	35	31	13	8	6	2192.12.12.120	M12	120	36	18	12	10	2192.12.20.300	M20	300	52	30	20	17
2192.12.08.040	M8	40	28	13	8	6	2192.12.12.130	M12	130	36	18	12	10	2192.12.24.120	M24	120	60	36	24	19
2192.12.08.045	M8	45	28	13	8	6	2192.12.12.140	M12	140	36	18	12	10	2192.12.24.130	M24	130	60	36	24	19
2192.12.08.050	M8	50	28	13	8	6	2192.12.12.150	M12	150	36	18	12	10	2192.12.24.140	M24	140	60	36	24	19
2192.12.08.055	M8	55	28	13	8	6	2192.12.12.180	M12	180	36	18	12	10	2192.12.24.150	M24	150	60	36	24	19
2192.12.08.060	M8	60	28	13	8	6	2192.12.12.220	M12	220	36	18	12	10	2192.12.24.160	M24	160	60	36	24	19
2192.12.08.070	M8	70	28	13	8	6	2192.12.16.040	M16	40	34	24	16	14	2192.12.24.180	M24	180	60	36	24	19
2192.12.08.075	M8	75	28	13	8	6	2192.12.16.050	M16	50	44	24	16	14	2192.12.24.200	M24	200	60	36	24	19
2192.12.08.080	M8	80	28	13	8	6	2192.12.16.060	M16	60	54	24	16	14	2192.12.30.140	M30	140	72	45	30	22
2192.12.08.090	M8	90	28	13	8	6	2192.12.16.065	M16	65	44	24	16	14	2192.12.30.160	M30	160	72	45	30	22



Hexagon socket head cap screw, with low profile head and key guide, DIN 6912 - Strength class 8.8



2192.20.

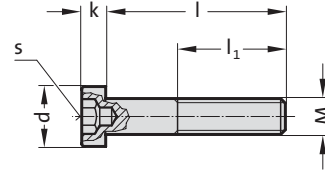

2192.20. Hexagon socket head cap screw, with low profile head and key guide, DIN 6912 - Strength class 8.8

Order No	M	l	l ₁	d	k	s	Order No	M	l	l ₁	d	k	s
2192.20.04.008	M4	8	6	7	2.8	3	2192.20.06.035	M6	35	18	10	4	5
2192.20.04.010	M4	10	8	7	2.8	3	2192.20.06.040	M6	40	18	10	4	5
2192.20.04.012	M4	12	10	7	2.8	3	2192.20.06.045	M6	45	18	10	4	5
2192.20.04.016	M4	16	14	7	2.8	3	2192.20.06.050	M6	50	18	10	4	5
2192.20.04.020	M4	20	14	7	2.8	3	2192.20.08.012	M8	12	7.3	13	5	6
2192.20.04.025	M4	25	14	7	2.8	3	2192.20.08.016	M8	16	11.3	13	5	6
2192.20.04.030	M4	30	14	7	2.8	3	2192.20.08.018	M8	18	13.3	13	5	6
2192.20.04.035	M4	35	14	7	2.8	3	2192.20.08.020	M8	20	15.3	13	5	6
2192.20.04.040	M4	40	14	7	2.8	3	2192.20.08.025	M8	25	20.3	13	5	6
2192.20.05.008	M5	8	5.4	8.5	3.5	4	2192.20.08.030	M8	30	22	13	5	6
2192.20.05.010	M5	10	7.4	8.5	3.5	4	2192.20.08.035	M8	35	22	13	5	6
2192.20.05.012	M5	12	9.4	8.5	3.5	4	2192.20.08.040	M8	40	22	13	5	6
2192.20.05.020	M5	20	17.4	8.5	3.5	4	2192.20.08.045	M8	45	22	13	5	6
2192.20.05.025	M5	25	16	8.5	3.5	4	2192.20.08.050	M8	50	22	13	5	6
2192.20.05.030	M5	30	16	8.5	3.5	4	2192.20.08.060	M8	60	22	13	5	6
2192.20.05.035	M5	35	16	8.5	3.5	4	2192.20.10.020	M10	20	14.5	16	6.5	8
2192.20.05.040	M5	40	16	8.5	3.5	4	2192.20.10.025	M10	25	19.5	16	6.5	8
2192.20.06.008	M6	8	4.3	10	4	5	2192.20.10.030	M10	30	25.5	16	6.5	8
2192.20.06.010	M6	10	6.3	10	4	5	2192.20.10.060	M10	60	26	16	6.5	8
2192.20.06.012	M6	12	8.3	10	4	5	2192.20.10.080	M10	80	26	16	6.5	8
2192.20.06.016	M6	16	12.3	10	4	5	2192.20.10.090	M10	90	26	16	6.5	8
2192.20.06.018	M6	18	14.3	10	4	5	2192.20.12.030	M12	30	20	18	7.5	10
2192.20.06.020	M6	20	16.3	10	4	5	2192.20.12.035	M12	35	25	18	7.5	10
2192.20.06.025	M6	25	21.3	10	4	5	2192.20.16.040	M16	40	0	24	8	14
2192.20.06.030	M6	30	18	10	4	5							

Hexagon socket head cap screw, with low profile head, DIN 7984 - Strength class 8.8

2192.40.

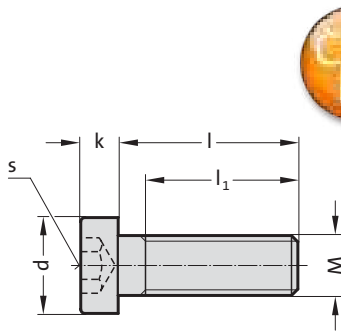

2192.40. Hexagon socket head cap screw, with low profile head, DIN 7984 - Strength class 8.8

Order No	M	l	l ₁	d	k	s	Order No	M	l	l ₁	d	k	s
2192.40.04.008	M4	8	5.9	7	2.8	2.5	2192.40.06.025	M6	25	22	10	4	4
2192.40.04.010	M4	10	7.9	7	2.8	2.5	2192.40.06.030	M6	30	18	10	4	4
2192.40.04.012	M4	12	9.9	7	2.8	2.5	2192.40.06.035	M6	35	18	10	4	4
2192.40.04.016	M4	16	13.9	7	2.8	2.5	2192.40.06.040	M6	40	18	10	4	4
2192.40.04.020	M4	20	17.9	7	2.8	2.5	2192.40.08.012	M8	12	8.25	13	5	5
2192.40.04.025	M4	25	14	7	2.8	2.5	2192.40.08.016	M8	16	12.25	13	5	5
2192.40.04.030	M4	30	14	7	2.8	2.5	2192.40.08.020	M8	20	16.25	13	5	5
2192.40.04.035	M4	35	14	7	2.8	2.5	2192.40.08.025	M8	25	21.25	13	5	5
2192.40.04.040	M4	40	14	7	2.8	2.5	2192.40.08.030	M8	30	26.25	13	5	5
2192.40.05.008	M5	8	0	8.5	3.5	3	2192.40.08.035	M8	35	22	13	5	5
2192.40.05.010	M5	10	7.6	8.5	3.5	3	2192.40.08.040	M8	40	22	13	5	5
2192.40.05.012	M5	12	9.6	8.5	3.5	3	2192.40.08.045	M8	45	22	13	5	5
2192.40.05.016	M5	16	13.6	8.5	3.5	3	2192.40.08.050	M8	50	22	13	5	5
2192.40.05.020	M5	20	17.6	8.5	3.5	3	2192.40.08.060	M8	60	22	13	5	5
2192.40.05.025	M5	25	22.6	8.5	3.5	3	2192.40.10.020	M10	20	15.5	16	6	7
2192.40.05.030	M5	30	16	8.5	3.5	3	2192.40.10.025	M10	25	20.5	16	6	7
2192.40.05.035	M5	35	16	8.5	3.5	3	2192.40.10.030	M10	30	25.5	16	6	7
2192.40.05.040	M5	40	16	8.5	3.5	3	2192.40.10.060	M10	60	26	16	6	7
2192.40.06.010	M6	10	7	10	4	4	2192.40.10.080	M10	80	26	16	6	7
2192.40.06.012	M6	12	9	10	4	4	2192.40.10.090	M10	90	26	16	6	7
2192.40.06.016	M6	16	13	10	4	4	2192.40.12.030	M12	30	24.75	18	7	8
2192.40.06.020	M6	20	17	10	4	4	2192.40.12.035	M12	35	29.75	18	7	8

Hexagon socket countersunk head cap screw, ISO 10642 - Strength class 8.8



2192.30.

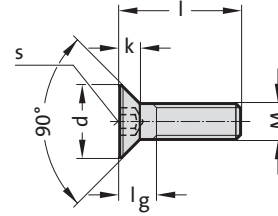

2192.30. Hexagon socket countersunk head cap screw, ISO 10642 - Strength class 8.8

Order No	M	l	l _g	d	k	s
2192.30.03.006	M3	6	3.2	6	1.7	2
2192.30.03.008	M3	8	3.2	6	1.7	2
2192.30.03.010	M3	10	3.2	6	1.7	2
2192.30.04.008	M4	8	4.4	8	2.3	2.5
2192.30.05.010	M5	10	5.2	10	2.8	3
2192.30.05.012	M5	12	5.2	10	2.8	3
2192.30.06.010	M6	10	6.3	12	3.3	4
2192.30.06.012	M6	12	6.3	12	3.3	4
2192.30.06.016	M6	16	6.3	12	3.3	4
2192.30.06.020	M6	20	6.3	12	3.3	4
2192.30.06.025	M6	25	6.3	12	3.3	4
2192.30.08.016	M8	16	8.2	16	4.4	5
2192.30.08.020	M8	20	8.2	16	4.4	5
2192.30.08.025	M8	25	8.2	16	4.4	5
2192.30.10.020	M10	20	10	20	5.5	6
2192.30.10.025	M10	25	10	20	5.5	6
2192.30.10.040	M10	40	10	20	5.5	6
2192.30.12.030	M12	30	11.8	24	6.5	8
2192.30.12.050	M12	50	11.8	24	6.5	8



Flat mushroom head screw with hexagon socket

2192.61.

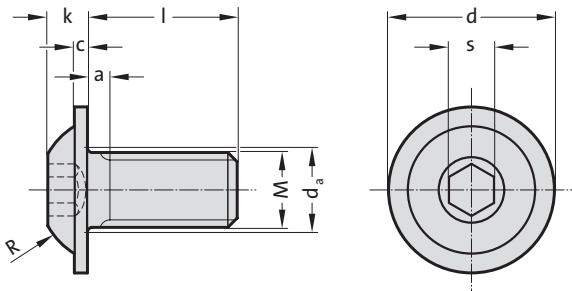

Mounting example

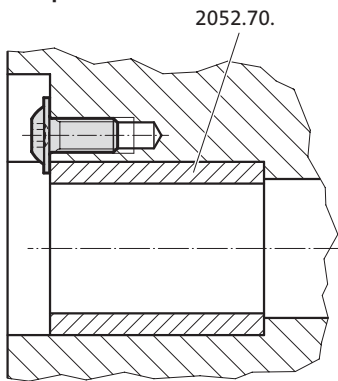

Material:

Strength class 10.9 = Code No 1.

2192.61. Flat mushroom head screw with hexagon socket

Order No	M	l	k	s	c	a	d _a	d	R
2192.61.06.012	M6	12	3.2	4	1.2	2	7	13.27	5.6
2192.61.06.016	M6	16	3.2	4	1.2	2	7	13.27	5.6
2192.61.06.020	M6	20	3.2	4	1.2	2	7	13.27	5.6
2192.61.08.016	M8	16	4.3	5	1.5	2.5	9.2	17.77	7.5
2192.61.08.020	M8	20	4.3	5	1.5	2.5	9.2	17.77	7.5
2192.61.08.025	M8	25	4.3	5	1.5	2.5	9.2	17.77	7.5
2192.61.10.020	M10	20	5.3	6	1.75	3	11.2	22.18	10



2192.90.

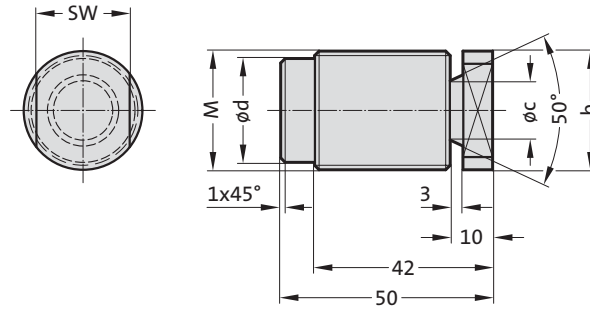

Description:

Repair solution:
Screw plugs are used to seal off defective boreholes, pass-through holes or shrink holes.

Note:

Screw in the screw plug as far as it will go (minimum screw-in length = diameter).
The screw plug can be secured to prevent it becoming loose during reworking by applying, for example, high-strength LOCTITE® (order no. 281.270).
Remove width across flats and protubing thread mechanically.

2192.90. Screw plug

Order No	Material	M	b	c	d	SW*
2192.90.1.12.150	C15 (1.0401)	M12x1,5	12	8	8.5	10
2192.90.1.16.150	C15 (1.0401)	M16x1,5	16	10	12.5	12
2192.90.1.20.150	C15 (1.0401)	M20x1,5	20	12	16.5	17
2192.90.1.24.150	C15 (1.0401)	M24x1,5	24	14	20.5	19
2192.90.1.28.150	C15 (1.0401)	M28x1,5	28	14	24.5	22
2192.90.1.30.150	C15 (1.0401)	M30x1,5	30	12	27.4	22
2192.90.1.32.150	C15 (1.0401)	M32x1,5	32	14	28.5	22
2192.90.2.12.150	GG25 (EN-GJL-250)	M12x1,5	12	8	8.5	10
2192.90.2.16.150	GG25 (EN-GJL-250)	M16x1,5	16	10	12.5	12
2192.90.2.20.150	GG25 (EN-GJL-250)	M20x1,5	20	12	16.5	17
2192.90.2.24.150	GG25 (EN-GJL-250)	M24x1,5	24	14	20.5	19
2192.90.2.28.150	GG25 (EN-GJL-250)	M28x1,5	28	14	24.5	22
2192.90.2.30.150	GG25 (EN-GJL-250)	M30x1,5	30	12	27.4	22
2192.90.2.32.150	GG25 (EN-GJL-250)	M32x1,5	32	14	28.5	22

*SW = width across flats



Clamping tool set

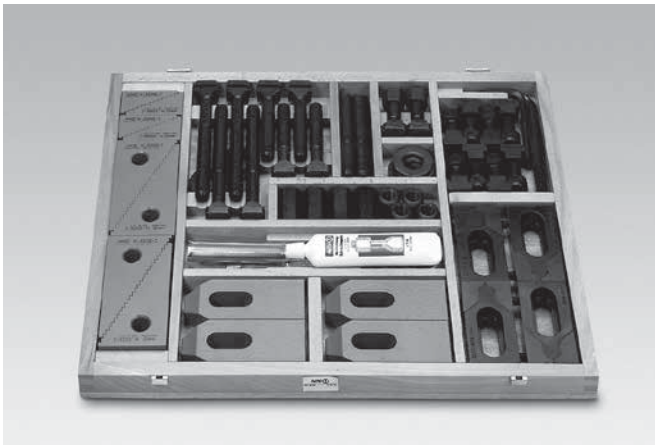

Clamping tool set

with clamping jaws and screw paste.

The clamping tool set is designed for machine tools with bedplates that have fixing slots and they contain all the necessary components for fast clamping of tools, devices and workpieces. All parts are interchangeable and complementary to each other. They are made of high tensile steel to DIN or company standards. Bolt items strength class 8 or 10. The wooden box has a detachable hinged cover.

2140.01.01. Clamping tool set

Order No 2140.01.01...		...10.10	...12.12	...12.14	...16.16	...16.18
Contents		M 10×10	M 12×12	M 12×14	M 16×16	M 16×18
Universal-clamping units	Size No.	1 2 3 4 4 2	2 3 4 4	2 3 4 4	2 3 4 4	2 3 4 4
Step clamps	Size No.	11×80 4	14×100 4	14×100 4	18×125 4	18×125 4
Screws for fixing slots DIN 787 (Order No 2140.30.)	Size No.	100 63 40 4 4 2	125 80 50 4 4 2	125 80 50 4 4 2	160 100 63 4 4 2	160 100 63 4 4 2
Pin screws	Size No.	80 4	100 4	100 4	125 4	125 4
Hexagonal nuts 1.5 d deep	Size No.	M10 6	M12 6	M12 6	M16 6	M16 6
Conical sockets, similar to DIN	Size No.	M10 6	M12 6	M12 6	M16 6	M16 6
Extension nuts 3.0 d deep	Size No.	M10 4	M12 4	M12 4	M16 4	M16 4
Clamping jaws, type Bulle	Size No.	12 4	12 4	14 4	16 4	18 4
T-slot scraper	Size No.	- -	- -	14-20 1	14-20 1	14-20 1
Ring/open ended spanners	Size No.	16×16 1	18×18 1	18×18 1	24×24 1	24×24 1
Screw paste	No.	1	1	1	1	1



Clamping Tool Set

Clamping tool set

With spring-mounted clamp holder and screw paste.

Description as 2140.01.01 but without clamping jaws.

Contains 4 spring-mounted clamp holders instead.



2140.01.02. Clamping Tool Set

Order No 2140.01.02...		...10.10	...12.12	...12.14	...16.16	...16.18	...20.20	...20.22	...20.24
Contents		M 10×10	M 12×12	M 12×14	M 16×16	M 16×18	M 20×20	M 20×22	M 20×24
Universal-clamping units	Size	1 2 3	2 3	2 3	2 3	2 3	2 3	2 3	2 3
	No.	4 4 2	4 4	4 4	4 4	4 4	4 4	4 4	4 4
Step clamps	Size	11×80	14×100	14×100	18×125	18×125	22×160	22×160	22×160
	No.	4	4	4	4	4	4	4	4
Screws for fixing slots DIN 787 (Order No. 2140.30.)	Size	100 63	125 80	125 80	160 100	160 100	200 125	200 125	-
	No.	4 4	4 4	4 4	4 4	4 4	4 4	4 4	-
Pin screws	Size	80	100	100	125	125	125	125	200 125
	No.	4	4	4	4	4	4	4	4 8
Hexagonal nuts 1.5 d deep	Size	M10	M12	M12	M16	M16	M20	M20	M20
	No.	6	4	4	4	4	6	6	6
Conical sockets, similar to DIN	Size	M10	M12	M12	M16	M16	M20	M20	M20
	No.	6	6	6	6	6	6	6	6
Extension nuts 3 d deep	Size	M10	M12	M12	M16	M16	M20	M20	M20
	No.	4	4	4	4	4	4	4	4
T-slot scraper	Size	-	-	14-20	14-20	14-20	14-20	22-32	22-32
	No.	-	-	1	1	1	1	1	1
Ring/open ended spanners	Size	16×16	18×18	18×18	24×24	24×24	30×30	30×30	30×30
	No.	1	1	1	1	1	1	1	1
Nuts for fixing slots	Size	-	-	-	-	-	-	-	M 20×24
	No.	-	-	-	-	-	-	-	8
Clamp holders	Size	1	2	2	3	3	4	4	4
	No.	4	4	4	4	4	4	4	4
Screw paste	No.	1	1	1	1	1	1	1	1

Representante para México

YUKME

Calle Ignacio Zaragoza #7
 Colonia Sta Ana Tlapaltitlán C.P. 50160
 Toluca de Lerdo, Estado de México
 info@yukme.com.mx · www.yukme.com.mx