



Ground Precision Components



Ground Precision Components

FIBRO Precision Components cover a very wide range of materials, shapes and sizes and thus permit virtually unrestricted selection even to highly individual requirements.

At Hassmersheim and also abroad, stock levels of Precision Components reach seven-digit figures. It is therefore quite likely that your particular choice will be available for immediate delivery. Should this not be the case then our flexible batch production schedules will ensure that delays are kept to a minimum.

Batch production in our interpretation not only spells prompt delivery but also exceptional quality. Starting with the arrival inspection of raw materials, every single manufacturing operation on FIBRO Precision Components is followed by a quality check. Lastly, an uncompromising final inspection of each and every part guarantees that the trade mark FIBRO is and remains synonymous with Quality.











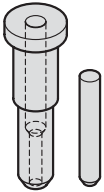

In view of the fact that a large portion of the Precision Components programme consists of punches and matrices, the importance of alignment in the operational die must be emphasized. Unless this requirement can be met to a high degree of accuracy, even the finest efforts in design and in the toolroom must fail! Die alignment ultimately depends on the guides – FIBRO Die Sets and Guide Elements were developed and are made with this postulate in mind.

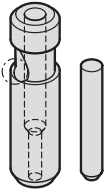
Tool life, production cost and work quality are to a large extent a function of tooling material selection versus strip stock characteristics and ancillary process conditions. A judicious choice from the wide range of materials for our punches and matrices will be facilitated by the orientation guide in this catalogue. Listing the principal characteristics of each material together with selection criteria, it is intended to help customers make the right choice.

Our experienced tooling specialists will assist you with further detailed information.

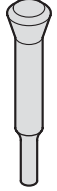
In keeping with the basic tenet of our firm, every effort is made to ensure that design, performance potential and quality of FIBRO Precision Components keep well abreast with latest technological developments.

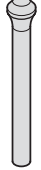
Contents

		E15				
	Comparative graphs					
		E16-17				
	Precision components - Description of materials					
	222. Punch DIN 9861 Shape DA	E18		232. Punch VDI 3374		E24
	223. Punch DIN 9861 Shape D / ISO 6752			233. Insert sleeve with thrust pin VDI 3374 Shape A		E25
	224. Punch DIN 9861 Shape CA			234. Insert sleeve with thrust pin VDI 3374 Shape B		E26
	225. Punch DIN 9861 Shape C			2281. Punch with tapered head 30°, Shape D		E27
	274. Punch similar to DIN 9861 Shape CA			2291. Punch with tapered head 30°, Shape C		E28
	275. Punch similar to DIN 9861 Shape C			2284.3. Punch with tapered head, Shape D		E30
				2284.00. Pilot counterbore for tapered-head punch		E31
				2206. Punch with tapered head, blank		E32

Contents

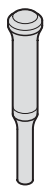

2216. E33
Punch with tapered head, stepped, round



2706. E34
Punch with tapered head, blank, with ejector pin



2716. E35
Punch with tapered head, stepped, round, with ejector pin

E36
Punches - Mounting guidelines



220. E37
Punch DIN 9844, Shape A



221. E38
Punch DIN 9844, Shape B

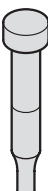

266. E39
Punch similar to VDI 3374

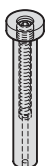

267. E40
Punch with ejector pin

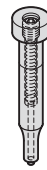

268. E41
Punch with ejector pin, stepped, short point



269. E42
Punch with ejector pin, stepped, long point



270. E45
Punch similar DIN 9844, Shape A



271. E46
Punch similar DIN 9844, Shape B



272. E47
Punch similar DIN 9861, Shape D



273. E48
Punch similar DIN 9861, Shape C











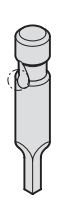
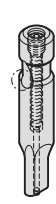
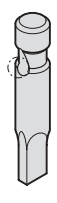
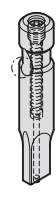
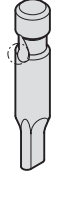

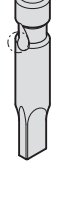

2202. E51
Ball lock punch, blank, light duty

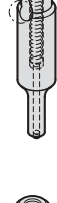

2212. E52
Ball lock punch, stepped, round, light duty

Contents

	2222. Ball lock punch, stepped, square, light duty	E53		2742. Ball lock punch, stepped, slot, with ejector pin, light duty	E61
	2232. Ball lock punch, stepped, rectangular, light duty	E54		2752. Ball lock punch, stepped, rectangle with radiussed corners, with ejector pin, light duty	E62
	2242. Ball lock punch, stepped, slot, light duty	E55		2204. Ball lock punch, punch larger than shaft, blank, light duty	E63
	2252. Ball lock punch, stepped, rectangle with radiussed corners, light duty	E56		2214. Ball lock punch, punch larger than shaft, round, light duty	E64
	2702. Ball lock punch, blank, with ejector pin, light duty	E57		2224. Ball lock punch, punch larger than shaft, square, light duty	E65
	2712. Ball lock punch, stepped, round, with ejector pin, light duty	E58		2234. Ball lock punch, punch larger than shaft, rectangular, light duty	E66
	2722. Ball lock punch, stepped, square, with ejector pin, light duty	E59		2244. Ball lock punch, punch larger than shaft, slot, light duty	E67
	2732. Ball lock punch, stepped, rectangular, with ejector pin, light duty	E60		2254. Ball lock punch, punch larger than shaft, rectangle with radiussed corners, light duty	E68

Contents

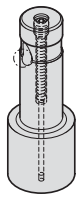

2704. **E69**
 Ball lock punch, punch larger than shaft, blank, with ejector pin, light duty

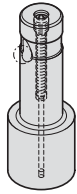

2714. **E70**
 Ball lock punch, punch larger than shaft, round, with ejector pin, light duty

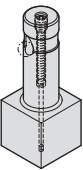

2724. **E71**
 Ball lock punch, punch larger than shaft, square, with ejector pin, light duty

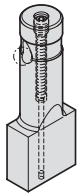

2734. **E72**
 Ball lock punch, punch larger than shaft, rectangular, with ejector pin, light duty

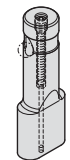

2744. **E73**
 Ball lock punch, punch larger than shaft, slot, with ejector pin, light duty

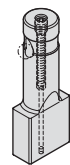

2754. **E74**
 Ball lock punch, punch larger than shaft, rectangle with radiussed corners, with ejector pin, light duty

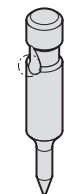

2262. **E75**
 Ball lock pilot pin, with tapered tip, light duty

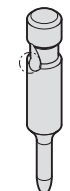

2272. **E76**
 Ball lock pilot pin, with parabolic tip, light duty



2203. **E77**
 Ball lock punch, blank, heavy duty



2213. **E78**
 Ball lock punch, stepped, round, heavy duty

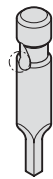

2223. **E79**
 Ball lock punch, stepped, square, heavy duty

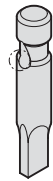

2233. **E80**
 Ball lock punch, stepped, rectangular, heavy duty

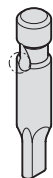

2243. **E81**
 Ball lock punch, stepped, slot, heavy duty

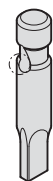

2253. **E82**
 Ball lock punch, stepped, rectangle with radiussed corners, heavy duty

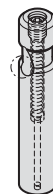

2703. **E83**
 Ball lock punch, blank, with ejector pin, heavy duty

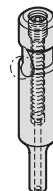

2713. **E84**
 Ball lock punch, stepped, round, with ejector pin, heavy duty

Contents

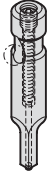
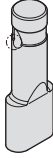
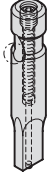
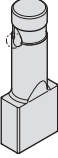
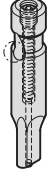
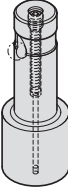
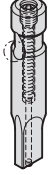
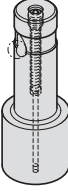
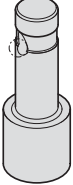
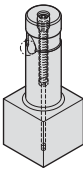
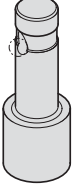
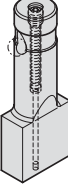
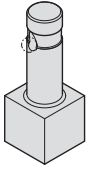
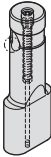
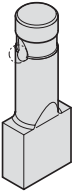
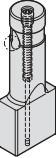
	2723. Ball lock punch, stepped, square, with ejector pin, heavy duty	E85		2245. Ball lock punch, punch larger than shaft, slot, heavy duty	E93
	2733. Ball lock punch, stepped, rectangular, with ejector pin, heavy duty	E86		2255. Ball lock punch, punch larger than shaft, rectangle with radiussed corners, heavy duty	E94
	2743. Ball lock punch, stepped, slot, with ejector pin, heavy duty	E87		2705. Ball lock punch, punch larger than shaft, blank, with ejector pin, heavy duty	E95
	2753. Ball lock punch, stepped, rectangle with radiussed corners, with ejector pin, heavy duty	E88		2715. Ball lock punch, punch larger than shaft, round, with ejector pin, heavy duty	E96
	2205. Ball lock punch, punch larger than shaft, blank, heavy duty	E89		2725. Ball lock punch, punch larger than shaft, square, with ejector pin, heavy duty	E97
	2215. Ball lock punch, punch larger than shaft, round, heavy duty	E90		2735. Ball lock punch, punch larger than shaft, rectangular, with ejector pin, heavy duty	E98
	2225. Ball lock punch, punch larger than shaft, square, heavy duty	E91		2745. Ball lock punch, punch larger than shaft, slot, with ejector pin, heavy duty	E99
	2235. Ball lock punch, punch larger than shaft, rectangular, heavy duty	E92		2755. Ball lock punch, punch larger than shaft, rectangle with radiussed corners, with ejector pin, heavy duty	E100

Contents

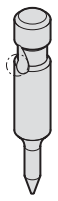

2263. E101
Ball lock pilot pin, with tapered tip, heavy duty



2273. E102
Ball lock pilot pin, with parabolic tip, heavy duty

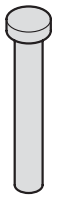

2201. E105
Punch, blank, ISO 8020

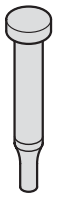

2211. E106
Punch, stepped, round, ISO 8020

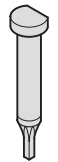

2221. E107
Punch, stepped, square, ISO 8020

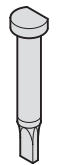

2231. E108
Punch, stepped, rectangular, ISO 8020

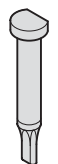

2241. E109
Punch, stepped, slot, ISO 8020

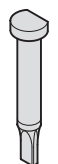

2251. E110
Punch, stepped, rectangle with radiused corners, ISO 8020

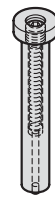

2701. E111
Punch, blank, with ejector pin, ISO 8020



2711. E112
Punch, stepped, round, with ejector pin, ISO 8020

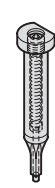

2721. E113
Punch, stepped, square, with ejector pin, ISO 8020

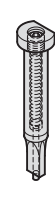

2731. E114
Punch, stepped, rectangular, with ejector pin, ISO 8020

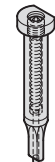

2741. E115
Punch, stepped, slot, with ejector pin, ISO 8020

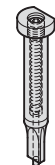

2751. E116
Punch, stepped, rectangle with radiused corners, with ejector pin, ISO 8020



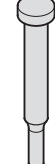

2261. E117
Pilot pin with tapered tip, ISO 8020

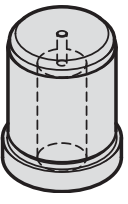
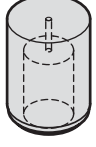
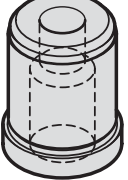
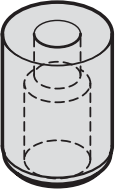

2271. E118
Pilot pin with parabolic tip, ISO 8020

Contents

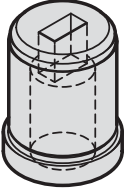
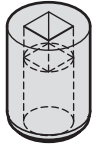
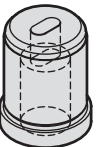
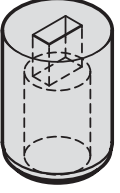
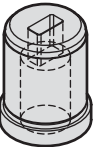
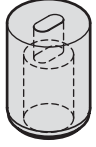
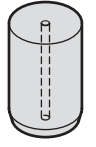
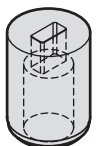
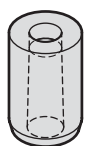
	2276. Pilot unit to Mercedes-Benz Standard	E119		2607. Matrix with shoulder, blank, ISO 8977	E135
	2606. Matrix without shoulder, blank, ISO 8977	E123		2617. Matrix with shoulder, round, ISO 8977	E136
	2616. Matrix without shoulder, round, ISO 8977	E124		2627. Matrix with shoulder, square, ISO 8977	E138
	Anti-rotation elements	E125-145		2637. Matrix with shoulder, rectangular, ISO 8977	E140
	2626. Matrix without shoulder, square, ISO 8977	E126		2647. Matrix with shoulder, slot, ISO 8977	E142
	2636. Matrix without shoulder, rectangular, ISO 8977	E128		2657. Matrix with shoulder, rectangle with radiussed corners, ISO 8977	E144
	2646. Matrix without shoulder, slot, ISO 8977	E130		2605. Matrix without shoulder, blank, Automotive Standard	E146
	2656. Matrix without shoulder, rectangle with radiussed corners, ISO 8977	E132		2615. Matrix without shoulder, round, Automotive Standard	E147

Contents

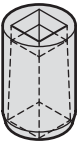
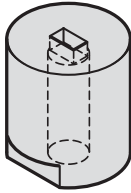
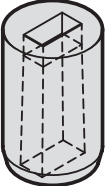
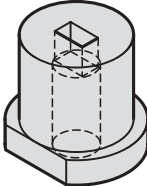
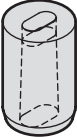
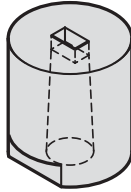
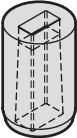
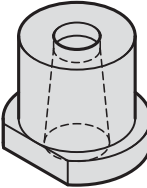
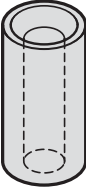
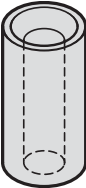
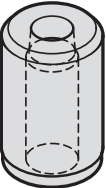
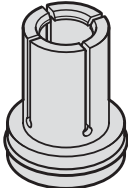
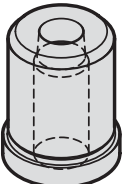
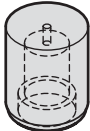
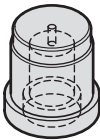
	2625. Matrix without shoulder, square, Automotive Standard	E148		2602. Matrix without collar, cylindrical	E156
	2635. Matrix without shoulder, rectangular, Automotive Standard	E149		2612. Matrix with collar, cylindrical	E157
	2645. Matrix without shoulder, slot, Automotive Standard	E150		2601. Matrix without collar, conical	E158
	2655. Matrix without shoulder, rectangle with radiused corners, Automotive Standard	E151		2611. Matrix with collar, conical	E159
	262. Guide bush for punch DIN 9845, Shape C	E152	E161-165 Standardised special shapes		
	2621. Guide bush for punch ISO 8978	E153			
	260. Matrix without collar, DIN 9845 Shape A	E154		2618. Dynamic stripping element (DAE)	E166
	261. Matrix with collar, DIN 9845 Shape B	E155		2618.06. Matrix without collar for dynamic stripper (DAE), blank	E169
				2618.07. Matrix with collar for dynamic stripper (DAE), blank	E170

Contents

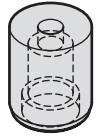

2618.16. **E171**

Matrix without collar for dynamic stripper (DAE), round

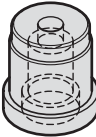

2618.17. **E172**

Matrix with collar for dynamic stripper (DAE), round

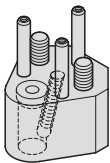

2664.05. **E174**

Triangle retainer for ball-lock punches, light duty

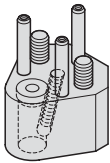

2664.06. **E175**

Triangle retainer for ball-lock punches, heavy duty

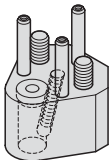

2664.07. **E176**

Triangle retainer for ball-lock punches, light duty

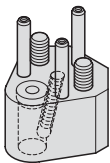

2664.10. **E177**

Triangle retainer for ball-lock punches, heavy duty

E178

Accessories for Retainers, triangular, for Ball-Lock Punches

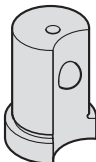

2668.2. **E179**

ACCU-LOCK Fixture device for ball-lock punches, light duty

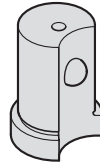

2668.3. **E180**

ACCU-LOCK Fixture device for ball-lock punches, heavy duty

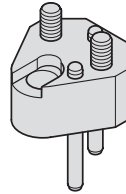

2664.02. **E182**

Triangle retainer, for punches ISO 8020 without anti-rotation element

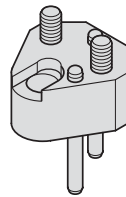

2664.04. **E183**

Triangle retainer, for punches ISO 8020 with anti-rotation element

E184

Accessories for retainers, triangular, for punches ISO 8020

2665.01. **E184**

Pressure plate

E185

Accessories for punches

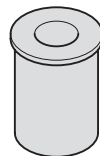

2431.7. **E186**

Stripping unit for punches



2667.1. **E187**

Stripping unit - Pressure plate

Contents

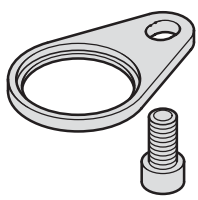

2667.2. E188
Stripping unit - Mounting plate

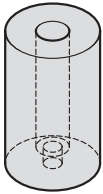

243.7. E190
Elastomer Stripper

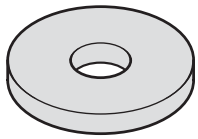

243.7. .1 E191
Washer

High-Precision special parts to customer's drawings
E192-193

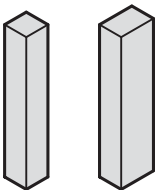

230. E194
Punch without head, square / rectangular, Shape A

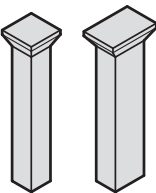

231. E195
Punch with head, square / rectangular, Shape B



236.1. E196
Dowel pin with internal extracting thread, similar to DIN EN ISO 8735



2361.1. E197
Dowel pin with internal extracting thread, according to DIN EN ISO 8735



236.001. E198
FIBROZIPP



265.1. E200
Liner bush for dowel pin, for bonding

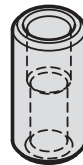

2650.1. E201
Liner bush for dowel pin, for push fit



235.1. E202
Dowel pin similar to DIN EN ISO 8734



2351.1. E203
Dowel pin according to DIN EN ISO 8734

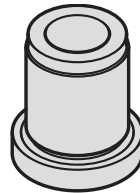

276. E204
Drill bush with collar, DIN 172, Shape A



277. E205
Drill bush without collar, DIN 179, Shape A



240.1./2. E206
Gauge pin DIN 2269

Contents

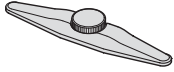

240.45. E208
Gauge pin holder

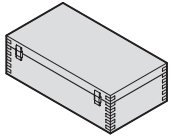

240.91. E208
Wooden box

240.92. E208
Wooden box



240.11. E209
Gauge pin with handle

240.22. E209
Gauge pin with handle

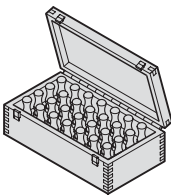

240.31. E209
Gauge pins - boxed set

240.32. E209
Gauge pins - boxed set

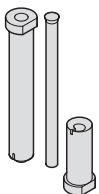

2282.01. E210
Punching and embossing unit with matrix for punched holes and self tapping screws

Comparative Graphs

Compressive strength (0,2 proof stress)

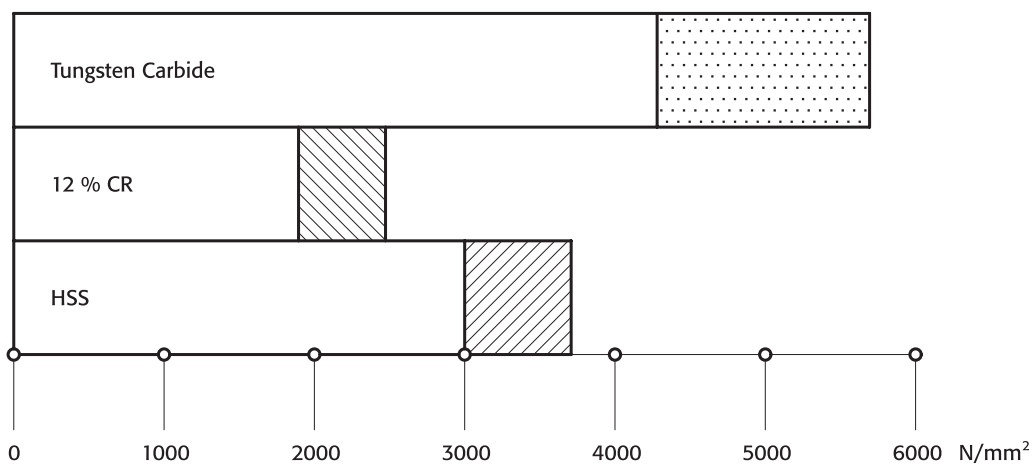

Flexural strength

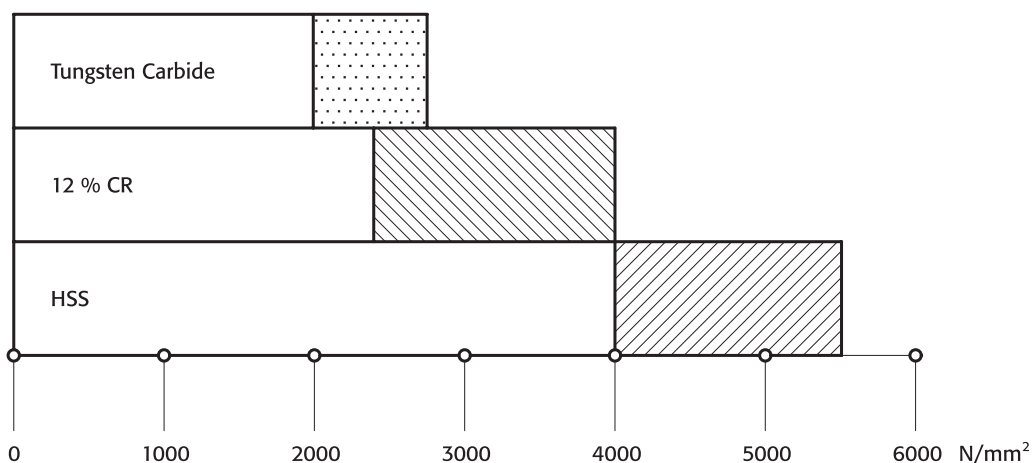

Hardness Vickers

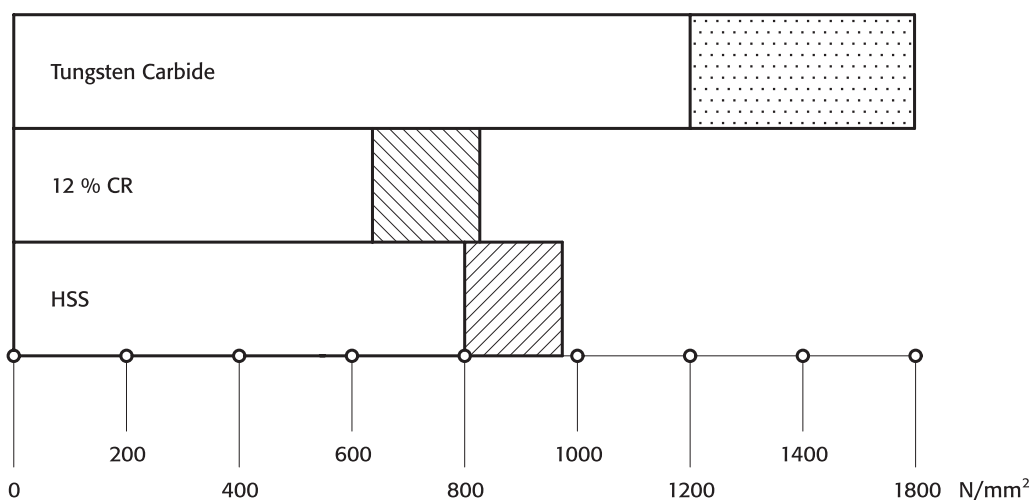

FIBRO Punches and Matrixes – Description of Materials

WS = Alloy Tool Steel

Material No 1.2210, 1.2516, 1.2842 or similar.
 Characteristics: Hard and tough tool steel, medium wear resistance.
 Application Field: Piercing/blanking dies for mild steel, low carbon steels, non-ferrous metals, plastics, paper.

WS = material code number = "1"
 e.g. Order No = 239.1 ...

HWS = High Carbon – High Chrome Tool Steel (12% Cr)

Material No 1.2436, 1.2379 or similar.
 Characteristics: High resistance to wear.
 Application Field: Piercing/blanking dies of all types, trim dies, for all carbon steels, alloy steels, non-ferrous metals, plastics, paper.

HWS = material code number = "2"
 e.g. Order No = 260.2 ...

HSS = High Speed Steel

Material No 1.3343 or similar.
 Characteristics: High wear resistance; high tempering curve permits certain surface treatments.
 Application Field: Piercing/blanking dies of all types – for tough materials e.g. spring steel, lamination steels, and abrasive papers as well as plastics.

HSS = material code number = "3"
 e.g. Order No = 220.3 ...

ASP 23 ASP 2023 = High Speed Steel on Powder-Metallurgic Basis

Characteristics: High wear resistance – greater toughness due to excellent homogeneity.
 Application Field: Same as HSS.

ASP 23
ASP 2023 = material code number = "6"
 e.g. Order No = 223.6 ...

HST = High Speed Steel, Nitrided

Characteristics: High wear resistance – reduced galling tendency on account of nitrides infused into top layer of material.
 Application Field: Piercing/blanking dies of all types – for very hard and abrasive materials.

HST = material code number = "4"
 e.g. Order No = 223.4 ...

FIBRO Punches and Matrixes – Description of Materials

HZ	=	Hard-coated Tooling Components for High-Performance
		HZC Composite Vapour Deposition (CVD) TIC-TIN Coating
Carrier Materials:		HSS Material No 1.3207 and 1.3343 etc. HCHC Material No 1.2379 and 1.2436 etc.
Properties:		The titanium carbide substrate provides a pressure-resistant bond with the carrier metal, while the outer layer of titanium nitride offers the well-known advantages of optimum tribologic behaviour in contact with the stamping stock. By virtue of its outstanding wear resistance, the TIN-layer largely eliminates seizing and cold welding problems in stamping. Surface Hardness: approx. 3500 HV 0,05 Coating Thickness: 5 to 8 µm approx.
Applications:		All tooling components subject to high demands on wear resistance and performance, especially punches in progression/combination tools, as well as cold extrusion punches etc. Owing to distortion problems, TIC-TIN is not recommended for parts with a length/thickness ratio than 20:1.
		TIC-TIN = material code number = "5" e. g. Order No = 223.5 ...
		HZN Titanium Nitride Coating TIN-PVD (physical vapour deposition).
Carrier Material:		HSS Material No 1.3207 and 1.3343 etc. HCHC Material No 1.2379 (HCHC-steels are of conditional suitability)
Properties:		The TIN-coating offers excellent frictional characteristics but its compressive strength remains inferior to TIC-TIN deposits. The TIN-deposition process can be applied to partial, selected areas of the tooling component. Surface Hardness: approx. 2300 HV 0,05 Coating Thickness: 2–4 µm < Ø 20 = 1,5 µm ± 20 %
Applications:		Tooling for thin stamping stock such as cold rolled spring steel, zinc-galvanized sheet and strip, copper-beryllium bronze, german silver, and solenoid lamination steels. Note that the ratio stock thickness to punch point diameter should not exceed 1:3.
		TIN = material code number = "0" e. g. Order No = 223.0 ...
HM	=	Tungsten Carbide
Characteristics:		Hard-sintered carbide on WC-basis and of recognized properties; produced by powder-metallurgic processes, FIBRO's exclusively used HIP-densified carbide exhibits much enhanced flexural strength and reduced residual porosity.
Application Field:		Die components for highest performance and very large stamping volumes – for altogether ultimate demands on tool life.
		HM = material code number = "9" e. g. Order No = 270.9 ...
NWA	=	Hot-Work Tool Steel – Suitable for Nitriding
		Material No 1.2344 or similar.
Characteristics:		Chrome-Molybdenum-Vanadium hot working die steel; core strength: > 1400 N/mm ² ; temperature resistant up to 650°C; surface hardness (nitrided) ≥ 950 HV 0,3.
Application Field:		Ejector pins for pressure diecasting, injection- and compression moulding processes, and generally for work at elevated temperatures.
		NWA = material code number = "8" e. g. Order No = 237.8 ...

Punch DIN 9861 Shape DA



222.

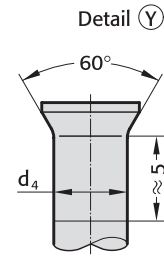
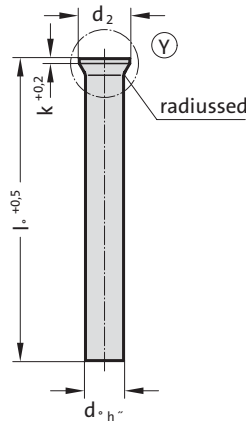

222. Punch DIN 9861 Shape DA

Gradation		d ₂	k	l ₁	71	80	100
d ₁	d ₁						
0.5	0.05	0.9	0.2		●	●	●
0.55	0.05	1	0.2		●	●	●
0.6	0.05	1.1	0.2		●	●	●
0.65	0.05	1.2	0.2		●	●	●
0.7 - 0.75	0.05	1.3	0.2		●	●	●
0.8 - 0.85	0.05	1.4	0.4		●	●	●
0.9 - 0.95	0.05	1.6	0.4		●	●	●
1 - 1.1	0.1	1.8	0.5		●	●	●
1.2 - 1.3	0.1	2	0.5		●	●	●
1.4 - 1.5	0.1	2.2	0.5		●	●	●
1.6 - 1.7	0.1	2.5	0.5		●	●	●
1.8 - 1.9	0.1	2.8	0.5		●	●	●
2	0.1	3	0.5		●	●	●
2.1 - 2.2	0.1	3.2	0.5		●	●	●
2.3 - 2.5	0.1	3.5	0.5		●	●	●
2.6 - 2.9	0.1	4	0.5		●	●	●
3 - 3.4	0.1	4.5	0.5		●	●	●
3.5 - 3.9	0.1	5	0.5		●	●	●
4 - 4.4	0.1	5.5	0.5		●	●	●
4.5 - 4.9	0.1	6	0.5		●	●	●
5 - 5.4	0.1	6.5	0.5		●	●	●
5.5 - 5.9	0.1	7	0.5		●	●	●
6 - 6.4	0.1	8	0.5		●	●	●
6.5 - 7	0.5	9	1		●	●	●
7.5 - 8	0.5	10	1		●	●	●
8.5 - 9	0.5	11	1		●	●	●
9.5 - 10	0.5	12	1		●	●	●
10.5 - 11	0.5	13	1		●	●	●
11.5 - 12	0.5	14	1		●	●	●
12.5 - 13	0.5	15	1		●	●	●
13.5 - 14	0.5	16	1.5		●	●	●
14.5 - 15	0.5	17	1.5		●	●	●
15.5 - 16	0.5	18	1.5		●	●	●

Material:

HSS
 Order No 222.3.
 Hardness:
 Shaft 64 ± 2 HRC
 Head 52 ± 3 HRC

HST
 Order No 222.4.
 Hardness:
 Surface ≥ 950 HV 0,3
 Head 52 ± 3 HRC

HZ - TIN (HSS)
 Order No 222.0.
 Hardness:
 Surface 2300 HV 0,05
 Head 52 ± 3 HRC

Description of FIBRO materials for tool and die components see at the beginning of Chapter E.

Execution:

Shaft precision ground. Head hot upset-forged and tempered. Residual upset bulge below head normally much smaller than permissible acc. to DIN 9861.

d₄: For d₁ < 1 mm d₄=d₁ + 0,02
 For d₁ ≥ 1 mm d₄=d₁ + 0,03

Stock lengths: 71, 80, 100 mm.
 other lengths and diameters on request!

Note:

Punches are also available without head

Ordering Code (example):

Punch DIN 9861 Shape DA	= 222.
Material MAT	HSS = 3.
Shaft diameter d ₁	0.5 mm = 0050.
Length l ₁	71 mm = 071
Order No	= 222. 3. 0050. 071

Punch DIN 9861 Shape D / ISO 6752



223.

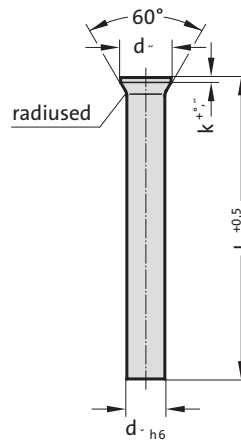

Material:

HSS
Order No 223.3.
Hardness:
Shaft 64 ± 2 HRC
Head 52 ± 3 HRC

HST
Order No 223.4.
Hardness:
Surface ≥ 950 HV 0,3
Head 52 ± 3 HRC

HZ - TIN (HSS)
Order No 223.0.
Hardness:
Surface 2300 HV 0,05
Head 52 ± 3 HRC

ASP 23 - ASP 2023
Order No 223.6.
Hardness:
Shaft 64 ± 2 HRC
Head 52 ± 3 HRC

Description of FIBRO materials for tool and die components see at the beginning of Chapter E.

Execution:

Head hot upset-forged and tempered. Shaft and head subsequently precision plunge-ground for perfect concentricity and full interchangeability with replacement punches.

Stock lengths: 71, 80, 100 mm.
other lengths and diameters on request!

223. Punch DIN 9861 Shape D / ISO 6752

Gradation		d ₂	k	l ₁	71	80	100
d ₁	d ₁						
0.5	0.05	0.9	0.2		●	●	●
0.55	0.05	1	0.2		●	●	●
0.6	0.05	1.1	0.2		●	●	●
0.65	0.05	1.2	0.2		●	●	●
0.7 - 0.75	0.05	1.3	0.2		●	●	●
0.8 - 0.85	0.05	1.4	0.4		●	●	●
0.9 - 0.95	0.05	1.6	0.4		●	●	●
1 - 1.1	0.1	1.8	0.5		●	●	●
1.2 - 1.3	0.1	2	0.5		●	●	●
1.4 - 1.5	0.1	2.2	0.5		●	●	●
1.6 - 1.7	0.1	2.5	0.5		●	●	●
1.8 - 1.9	0.1	2.8	0.5		●	●	●
2	0.1	3	0.5		●	●	●
2.1 - 2.2	0.1	3.2	0.5		●	●	●
2.3 - 2.5	0.1	3.5	0.5		●	●	●
2.6 - 2.9	0.1	4	0.5		●	●	●
3 - 3.4	0.1	4.5	0.5		●	●	●
3.5 - 3.9	0.1	5	0.5		●	●	●
4 - 4.4	0.1	5.5	0.5		●	●	●
4.5 - 4.9	0.1	6	0.5		●	●	●
5 - 5.4	0.1	6.5	0.5		●	●	●
5.5 - 5.9	0.1	7	0.5		●	●	●
6 - 6.4	0.1	8	0.5		●	●	●
6.5 - 7	0.5	9	1		●	●	●
7.5 - 8	0.5	10	1		●	●	●
8.5 - 9	0.5	11	1		●	●	●
9.5 - 10	0.5	12	1		●	●	●
10.5 - 11	0.5	13	1		●	●	●
11.5 - 12	0.5	14	1		●	●	●
12.5 - 13	0.5	15	1		●	●	●
13.5 - 14	0.5	16	1.5		●	●	●
14.5 - 15	0.5	17	1.5		●	●	●
15.5 - 16	0.5	18	1.5		●	●	●
16.5 - 17	0.5	19	1.5		●	●	●
17.5 - 18	0.5	20	1.5		●	●	●
18.5 - 19	0.5	21	1.5		●	●	●
19.5 - 20	0.5	22	1.5		●	●	●

Ordering Code (example):

Punch DIN 9861 Shape D / ISO 6752	= 223.
Material MAT	HSS = 3.
Shaft diameter d ₁	0.5 mm = 0050.
Length l ₁	71 mm = 071
Order No	= 223. 3.0050. 071

Punch DIN 9861 Shape CA



224.

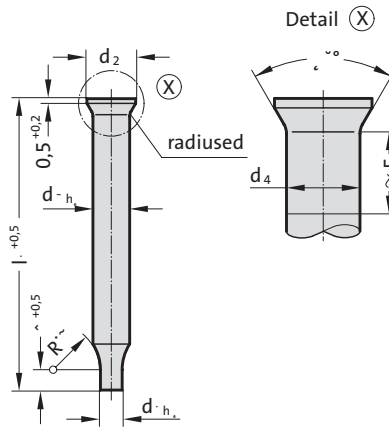

224. Punch DIN 9861 Shape CA

d_1	Gradation	d_2	d_3	d_4	l_1
0.1 - 1.5	0.05	3	2	2.03	71
1.55 - 2.95	0.05	4.5	3	3.03	71

Material:

HSS
 Order No 224.3.
 Hardness:
 Shaft 64 ± 2 HRC
 Head 52 ± 3 HRC

HZ - TIN (HSS)
 Order No 224.0.
 Hardnes:
 Surface 2300 HV 0,05
 Head 52 ± 3 HRC

Description of FIBRO materials for tool and die components see at the beginning of Chapter E.

Execution:

Shaft precision ground. Head subsequently hot upset-forged and tempered; residual upset-buge below head normally much smaller than permissible acc. to DIN 9861.

Stock lengths: 71 mm.
 Other lengths and diameters on request!

Ordering Code (example):

Punch DIN 9861 Shape CA	= 224.
Material MAT	HSS = 3.
Cutting diameter d_1	0.1 mm = 0010.
Length l_1	71 mm = 071
Order No	= 224. 3.0010. 071

Punch DIN 9861 Shape C



225.

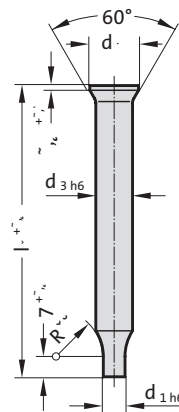

Material:

HSS
 Order No 225.3.
 Hardness:
 Shaft 64 ± 2 HRC
 Head 52 ± 3 HRC

HST
 Order No 225.4.
 Hardness:
 Surface ≥ 950 HV 0,3
 Head 52 ± 3 HRC

HZ - TIN (HSS)
 Order No 225.0.
 Hardness:
 Surface 2300 HV 0,05
 Head 52 ± 3 HRC

ASP 23 - ASP 2023
 Order No 225.6.
 Hardness:
 Shaft 64 ± 2 HRC
 Head 52 ± 3 HRC

Description of FIBRO materials for tool and die components see at the beginning of Chapter E.

Execution:

Head hot upset-forged and tempered. Shaft and head subsequently precision plunge-ground for perfect concentricity and full interchangeability with replacement punches.

Stock lengths: 71 mm.
 Other lengths and diameters on request!

225. Punch DIN 9861 Shape C

Gradation		d_2	d_3	l_1
d_1	d_1			
0.1 - 1.5	0.05	3	2	71
1.55 - 2.95	0.05	4.5	3	71

Ordering Code (example):

Punch DIN 9861 Shape C	= 225.
Material MAT	HSS = 3.
Cutting diameter d_1	0.1 mm = 0010.
Length l_1	71 mm = 071
Order No	= 225. 3. 0010. 071

Punch similar to DIN 9861 Shape CA



274.

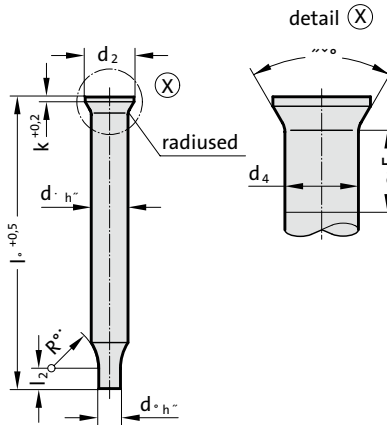

274. Punch similar to DIN 9861 Shape CA

Gradation		d_1	d_2	d_3	d_4	l_2	k	l_1	71	80	100
1 - 3.9	0.05	5.5	4	4.03	5 - 20	0.5			●	●	●
1.5 - 4.9	0.05	6.5	5	5.03	5 - 20	0.5			●	●	●
1.6 - 5.9	0.05	8	6	6.03	5 - 20	0.5			●	●	●
2.5 - 7.9	0.05	10	8	8.03	5 - 20	1			●	●	●
4 - 9.9	0.05	12	10	10.03	5 - 20	1			●	●	●
5 - 12.9	0.05	15	13	13.03	5 - 20	1			●	●	●
8 - 15.9	0.05	18	16	16.03	5 - 20	1.5			●	●	●

Description:

DIN 9861 restricts the range of stepped punches with conical head to shanks of 3 mm max. diameter and points of 2,95 mm max. diameter. Stepped punches of larger size are, however, quite popular owing to their rigidity and ability to sustain considerable stripping forces. In accommodation of this demand we supply larger sizes which are ground from stock sizes of the 222.-series.

Please select from those ranges and complete your order in accordance with the example on the right.

Material:

HSS
 Order No 274.3.
 Hardness:
 Shaft 64 ± 2 HRC
 Head 52 ± 3 HRC

HST
 Order No 274.4.
 Hardness:
 Surface ≥ 950 HV 0,3
 Head 52 ± 3 HRC

HZ - TIN (HSS)
 Order No 274.0.
 Hardness:
 Surface 2300 HV 0,05
 Head 52 ± 3 HRC

Description of FIBRO materials for tool and die components see at the beginning of Chapter E.

Execution:

Shaft precision ground. Head subsequently hot upset-forged and tempered; residual upset-buge below head normally much smaller than permissible acc. to DIN 9861.

Stock lengths: 71, 80, 100 mm.
 other lengths and diameters on request!

Ordering Code (example):

Punch similar to DIN 9861 Shape CA	= 274.
Material MAT	HSS = 3.
Shaft diameter d_s	8 mm = 0800.
Length l_1	71 mm = 071.
Cutting diameter d_1	2.5 mm = 0250.
Punch cutting length l_2	5 mm = 05
Order No	= 274. 3. 0800. 071. 0250. 05



Punch similar to DIN 9861 Shape C

275.

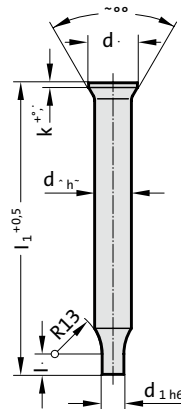

Description:

DIN 9861 restricts the range of stepped punches with conical head to shanks of 3 mm max. diameter and points of 2,95 mm max. diameter. Stepped punches of larger size are, however, quite popular owing to their rigidity and ability to sustain considerable stripping forces. In accommodation of this demand we supply larger sizes which are ground from stock sizes of the 223.-series
Please select from those ranges and complete your order in accordance with the example on the right.

Material:

HSS
Order No 275.3.
Hardness: Shaft 64 ± 2 HRC; Head 52 ± 3 HRC

HST
Order No 275.4.
Hardness: Surface ≥ 950 HV 0,3; Head 52 ± 3 HRC

HZ - TIN (HSS)
Order No 275.0.
Hardness: Surface 2300 HV 0,05; Head 52 ± 3 HRC

ASP 23 - ASP 2023
Order No 275.6.
Hardness: Shaft 64 ± 2 HRC; Head 52 ± 3 HRC

Description of FIBRO materials for tool and die components see at the beginning of Chapter E.

Execution:

Head hot upset-forged and tempered. Shaft and head subsequently precision plunge-ground for perfect concentricity and full interchangeability with replacement punches.
Stock lengths: 71, 80, 100 mm.
other lengths and diameters on request!

275. Punch similar to DIN 9861 Shape C

d ₁	Gradation			l ₂	k	l ₁	71	80	100
	d ₁	d ₂	d ₃						
1 - 3.9	0.05	5.5	4	5 - 20	0.5		●	●	●
1.5 - 4.9	0.05	6.5	5	5 - 20	0.5		●	●	●
1.6 - 5.9	0.05	8	6	5 - 20	0.5		●	●	●
2.5 - 7.9	0.05	10	8	5 - 20	1		●	●	●
4 - 9.9	0.05	12	10	5 - 20	1		●	●	●
5 - 12.9	0.05	15	13	5 - 20	1		●	●	●
8 - 15.9	0.05	18	16	5 - 20	1.5		●	●	●

Ordering Code (example):

Punch similar to DIN 9861 Shape C	= 275.
Material MAT	HSS = 3.
Shaft diameter d ₁	8 mm = 0800.
Length l ₁	71 mm = 071.
Cutting diameter d ₁	2.5 mm = 0250.
Punch cutting length l ₂	5 mm = 05
Order No	= 275. 3.0800. 071. 0250. 05

Punch VDI 3374



232.

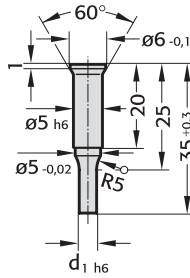

232. Punch VDI 3374

d_1	Gradation
2 - 5	0.1

Material:

HSS
 Order No 232.3.
 Hardness:
 Shaft 64 ± 2 HRC
 Head 52 ± 3 HRC

Description of FIBRO materials for tool and die components see at the beginning of Chapter E.

Execution:

Punch head hot upset-forged.
 Shaft and shoulder precision plunge-ground.

Note:

Matching insert sleeves 233. and 234.

Ordering Code (example):

Punch VDI 3374	= 232.
Material MAT HSS	= 3.
Cutting diameter d_1 2 mm	= 0200
Order No	= 232. 3.0200



Insert sleeve with thrust pin VDI 3374 Shape A

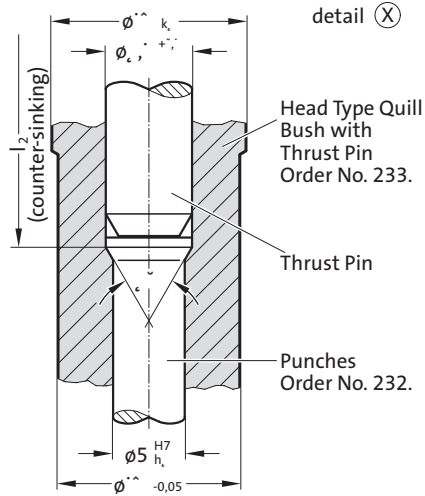

233.

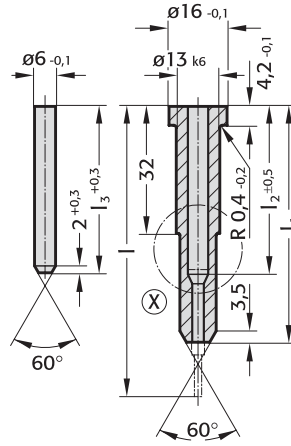

Material:

Insert sleeve:
Steel C 45 heat treated to 800 N/mm²
Thrust pin:
HWS, hardened 62 ± 2 HRC

Execution:

Insert sleeve: shaft precision ground
Thrust pin: ground

Note:

Matching punch 232.

233. Insert sleeve with thrust pin VDI 3374 Shape A

Order No	l	l ₁	l ₂	l ₃
233.7.048	63	48	29	29
233.7.057	71	57	37	37
233.7.065	80	65	46	46

Insert sleeve with thrust pin VDI 3374 Shape B



234.

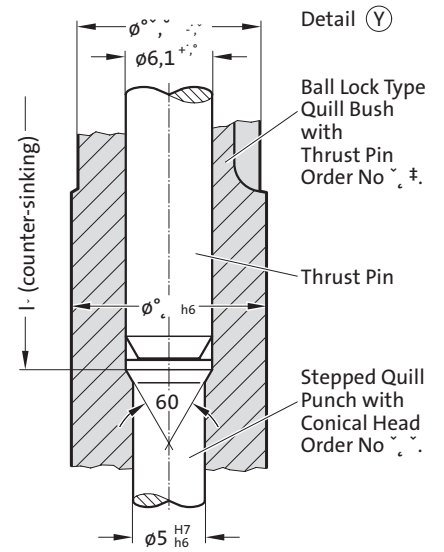
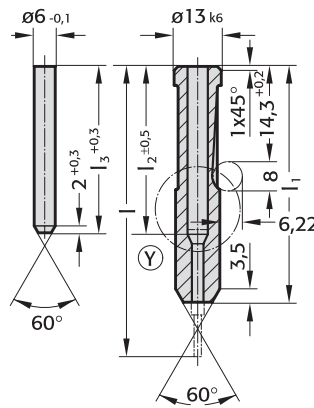

234. Insert sleeve with thrust pin VDI 3374 Shape B

Order No	l	l ₁	l ₂	l ₃
234.7.048	63	48	29	29
234.7.057	71	57	37	37
234.7.065	80	65	46	46

Material:

Insert sleeve:
Steel C 45 heat treated to 800 N/mm²
Thrust pin:
HWS, hardened 62 ± 2 HRC

Execution:

Insert sleeve: shaft precision ground
Thrust pin: ground

Note:

Matching punch 232.



Punch with tapered head 30°, Shape D

2281.

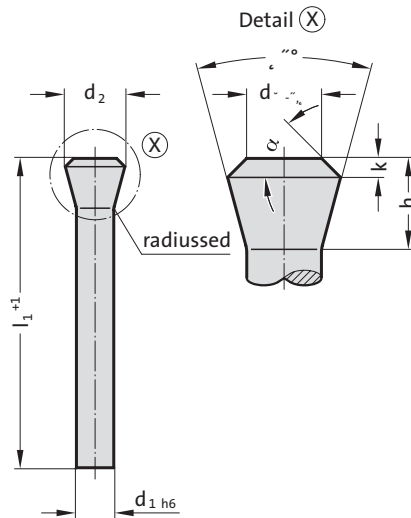

Material:

HSS
 Order No 2281.3.
 Hardness:
 Shaft 58 + 2 HRC
 Head ≤ 50 HRC

Description of FIBRO materials for tool and die components see at the beginning of Chapter E.

Execution:

Head hot upset-forged and tempered. Shaft and head subsequently precision plunge-ground for perfect concentricity and full interchangeability with replacement punches.

2281. Punch with tapered head 30°, Shape D

d ₁	d ₂	d ₄	h	k	α ± 1°	l ₁ 100	l ₁ 120
5.5	8.98	5.5	7.5	1	30	●	●
6	9.75	6	8	1	28	●	●
8	12.8	8	10	1	22.5	●	●
9	14.4	9	11	1	20	●	●
10	15.9	10	12	1	19	●	●
12	18.7	12	14	1.5	24	●	●
14	21.8	14	16	1.5	21	●	●
16	24.6	16	18	2	25	●	●

Ordering Code (example):

Punch with tapered head 30°, Shape D	= 2281.
Material MAT	HSS = 3.
Shaft diameter d ₁	5.5 mm = 0550.
Length l ₁	100 mm = 100
Order No	= 2281. 3. 0550. 100

Punch with tapered head 30°, Shape C

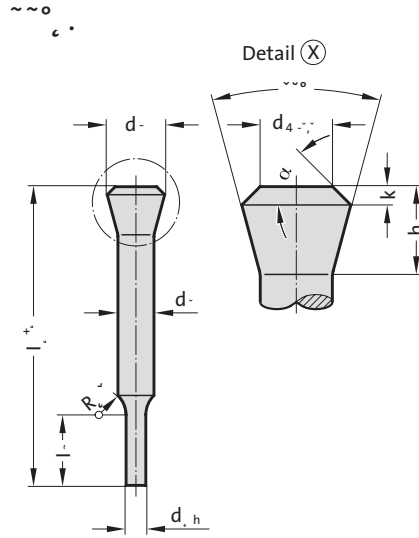

2291. Punch with tapered head 30°, Shape C

d ₃	d ₂	d ₄	h	k	α ±1°	l ₁	l ₂
5.5	8.98	5.5	7.5	1	30	100	120
6	9.75	6	8	1	28	●	●
8	12.8	8	10	1	22.5	●	●
9	14.4	9	11	1	20	●	●
10	15.9	10	12	1	19	●	●
12	18.7	12	14	1.5	24	●	●
14	21.8	14	16	1.5	21	●	●
16	24.6	16	18	2	25	●	●

Material:

HSS
 Order No 2291.3.
 Hardness:
 Shaft 58 + 2 HRC
 Head ≤ 50 HRC

Description of FIBRO materials for tool and die components see at the beginning of Chapter E.

Execution:

Head hot upset-forged and tempered. Shaft and head subsequently precision plunge-ground for perfect concentricity and full interchangeability with replacement punches.

d₁ and l₂ to customer's specifications!

Ordering Code (example):

Punch with tapered head 30°, Shape C	=2291.
Material MAT	HSS = 3.
Shaft diameter d ₃	5.5 mm = 0550.
Length l ₁	100 mm = 100.
Cutting diameter d ₁	2.75 mm = 0275.
Punch cutting length l ₂	5 mm = 005
Order No	=2291. 3. 0550. 100. 0275. 005

PUNCH WITH TAPERED HEAD, DIN 5118 SHAPE A

2284.3. Punch with tapered head, DIN 5118 Shape A

d ₁	d ₂	a	k	r	l	71	80	100	110
2	3	1	3	3.5		●	●	●	
2.1	3.2	1	3	5		●	●	●	
2.2	3.2	1	3	5		●	●	●	
2.3	3.5	1	3	5		●	●	●	
2.4	3.5	1	3	5		●	●	●	
2.5	3.5	1	3	5		●	●	●	
2.6	4	1	3	6.5		●	●	●	
2.7	4	1	3	6.5		●	●	●	
2.8	4	1	3	6.5		●	●	●	
2.9	4	1	3	6.5		●	●	●	
3.1	4.5	1	3	6.5		●	●	●	
3.2	4.5	1	3	6.5		●	●	●	
3.3	4.5	1	3	6.5		●	●	●	
3.4	4.5	1	3	6.5		●	●	●	
3.5	5	1	3	8		●	●	●	
3.6	5	1	3	8		●	●	●	
3.7	5	1	3	8		●	●	●	
3.8	5	1	3	8		●	●	●	
4.1	5.5	1.5	4	8		●	●	●	
4.2	5.5	1.5	4	8		●	●	●	
4.3	5.5	1.5	4	8		●	●	●	
4.4	5.5	1.5	4	8		●	●	●	
4.5	6	1.5	4	8		●	●	●	
4.6	6	1.5	4	8		●	●	●	
4.7	6	1.5	4	8		●	●	●	
4.8	6	1.5	4	8		●	●	●	
4.9	6	1.5	4	8		●	●	●	
5.1	7	1.5	4	10		●	●	●	
5.2	7	1.5	4	10		●	●	●	
5.5	8	1.5	4	10		●	●	●	
5.6	8	1.5	4	10		●	●	●	
6.1	9	1.5	4	10		●	●	●	
6.2	9	1.5	4	10		●	●	●	
6.3	9	1.5	4	10		●	●	●	
6.4	9	1.5	4	10		●	●	●	
6.5	10	1.5	4	12		●	●	●	●
7	10	1.5	4	12		●	●	●	
7.5	11	1.5	4	12		●	●	●	
7.7	11	1.5	4	12		●	●	●	
8.1	11	1.5	4	12		●	●	●	
8.5	13	1.5	4	15		●	●	●	●
9	13	1.5	4	15		●	●	●	●
9.5	14	1.5	4	15		●	●	●	
10.5	15	1.5	4	15		●	●	●	
11	15	1.5	4	15		●	●	●	
11.5	16	1.5	4	15		●	●	●	
12	16	1.5	4	15		●	●	●	●
12.5	17	1.5	4	15		●	●	●	
13.5	18	1.5	4	15		●	●	●	
14	18	1.5	4	15		●	●	●	●
14.5	19	1.5	4	15		●	●	●	
15	19	1.5	4	15		●	●	●	●
15.5	20	1.5	4	15		●	●	●	
17	21	1.5	4	15		●	●	●	●
18	22	1.5	4	15		●	●	●	●
19	23	1.5	4	15		●	●	●	
19.5	25	1.5	4	15		●	●	●	



2284.3.

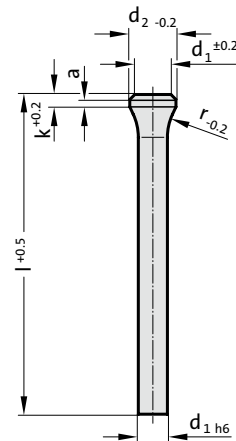

Material:

HSS
Order No 2284.3.
Hardness:
Shaft 62-66 HRC
Head 45-55 HRC

☞ Description of FIBRO materials for tool and die components see at the beginning of Chapter E.

Execution:

Shaft precision ground. Head subsequently hot upset-forged and tempered.

Note:

Matching piloted counterbore 2284.00.

Ordering Code (example):

Punch with tapered head, DIN 5118
Shape A = 2284.3.
Shaft diameter d₁ 5.2 mm = 0520.
Length l 80 mm = 080
Order No = 2284.3. 0520. 080



Piloted counterbore for tapered-head punch

2284.00. Piloted counterbore for tapered-head punch

d ₁	d ₅	d ₃	r ₁	l ₁
2	3.3	3.3	3.5	5
2.1	3.5	3.5	5	5
2.2	3.5	3.5	5	5
2.3	3.8	3.8	5	5
2.4	3.8	3.8	5	5
2.5	3.8	3.8	5	5
2.6	4.3	4.3	6.5	7
2.7	4.3	4.3	6.5	7
2.8	4.3	4.3	6.5	7
2.9	4.3	4.3	6.5	7
3	4.9	4.9	6.5	7
3.1	4.9	4.9	6.5	7
3.2	4.9	4.9	6.5	7
3.3	4.9	4.9	6.5	7
3.4	4.9	4.9	6.5	7
3.5	5.4	5.4	8	8
3.6	5.4	5.4	8	8
3.7	5.4	5.4	8	8
3.8	5.4	5.4	8	8
4	5.9	5.9	8	8
4.1	5.9	5.9	8	8
4.2	5.9	5.9	8	8
4.3	5.9	5.9	8	8
4.4	5.9	5.9	8	8
4.5	6.4	6.4	8	8
4.6	6.4	6.4	8	8
4.7	6.4	6.4	8	8
4.8	6.4	6.4	8	8
4.9	6.4	6.4	8	8
5	7.4	7.4	10	10
5.1	7.4	7.4	10	10
5.2	7.4	7.4	10	10
5.5	8.5	8.5	10	10
5.6	8.5	8.5	10	10
6	9.5	9.5	10	10
6.1	9.5	9.5	10	10
6.2	9.5	9.5	10	10
6.3	9.5	9.5	10	10
6.4	9.5	9.5	10	10
6.5	10.5	10.5	12	12
7	10.5	10.5	12	12
7.5	11.5	11.5	12	12
7.7	11.5	11.5	12	12
8	11.5	11.5	12	12
8.1	11.5	11.5	12	12
8.5	13.5	13	15	12
9	13.5	13	15	12
9.5	14.5	13	15	12
10	14.5	13	15	12
10.5	15.5	13	15	15
11	15.5	13	15	15
11.5	16.5	13	15	15
12	16.5	13	15	15
12.5	17.5	13	15	15
13	17.5	13	15	15
13.5	18.5	13	15	15
14	18.5	13	15	15
14.5	19.5	13	15	15
15	19.5	13	15	15
15.5	20.5	13	15	15
16	20.5	13	15	15
17	21.5	16	15	15
18	22.5	16	15	15
19	23.5	16	15	15
19.5	25.5	16	15	15
20	25.5	16	15	15

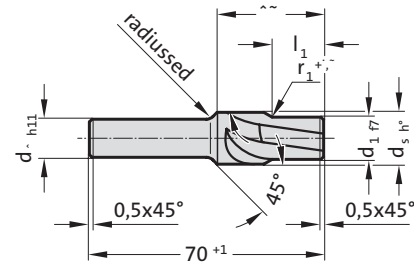

Material:
HSS, hardened 62-66 HRC

Execution:
Tempered and ground.

Ordering Code (example):

Piloted counterbore for tapered-head punch =2284.00.
 Shaft diameter d₁ 2 mm = 0200
 Order No =2284.00. 0200



PUNCH WITH TAPERED HEAD, BLANK, DIN 5118 SHAPE A



2206.

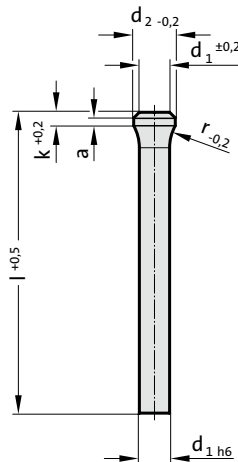

2206. Punch with tapered head, blank, DIN 5118 Shape A

d ₁ / Order No	d ₂	a	k	r	l (Order Code character)	71 (D)	80 (E)	90 (F)	100 (G)	120 (J)	150 (M)	200 (N)
3/(1)	4.5	1	3	6.5		●	●	●	●	●		
4/(2)	5.5	1.5	4	8		●	●	●	●	●		
5/(3)	7	1.5	4	10		●	●	●	●	●		
6/(4)	9	1.5	4	10		●	●	●	●	●		
8/(5)	11	1.5	4	12		●	●	●	●	●		
10/(6)	14	1.5	4	15		●	●	●	●	●	●	
13/(7)	17	1.5	4	15		●	●	●	●	●	●	●
16/(8)	20	1.5	4	15		●	●	●	●	●	●	●
20/(9)	25	1.5	4	15		●	●	●	●	●	●	●

Material:

HSS

Hardness:

Shaft 62-66 HRC

Head 45-55 HRC

☞ Description of FIBRO materials for tool and die components see at the beginning of Chapter E.

Execution:

Shaft precision ground. Head subsequently hot upset-forged and tempered.

Note:

Matching piloted counterbore 2284.00.

Matching retainer ring 2284.00.01.

Ordering Code (example):

2206.7G

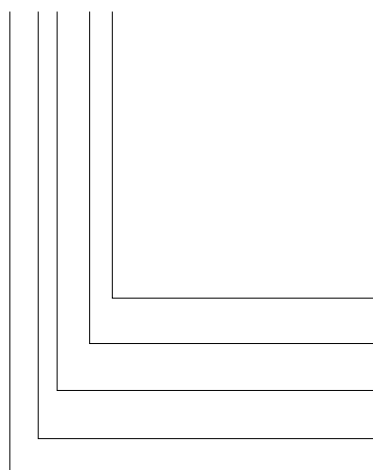

Length: l
100 mm
Diameter: d₁
13 mm
Type:
with tapered head
Execution:
blank
Punch:
without ejector pin

Order Code character
= (G)
Order No
= (7)
Order No
= (6)
Order No
= (0)
= 22



PUNCH WITH TAPERED HEAD, STEPPED, ROUND, DIN 5118 SHAPE B

2216.

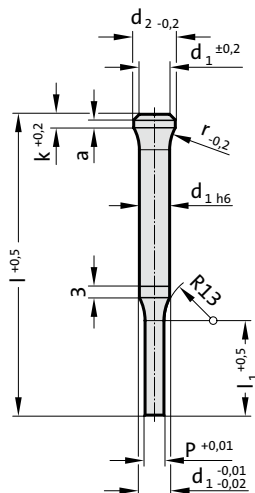

2216. Punch with tapered head, stepped, round, DIN 5118 Shape B

d ₁ / Order No	d ₂	p	l ₁ / Order No	a	k	r	l (Order Code character)	71 (D)	80 (E)	90 (F)	100 (G)	120 (J)	150 (M)	200 (N)
3 / (1)	4.5	0.8-2.9	8(1) 10(2)	1	3	6.5		●	●	●	●	●		
4 / (2)	5.5	1.0-3.9	8(1) 13(3)	1.5	4	8		●	●	●	●	●		
5 / (3)	7	1.5-4.9	13(3) 19(4)	1.5	4	10		●	●	●	●	●		
6 / (4)	9	1.6-5.9	13(3) 19(4)	1.5	4	10		●	●	●	●	●		
8 / (5)	11	2.5-7.9	19(4) 25(5)	1.5	4	12		●	●	●	●	●		
10 / (6)	14	4.0-9.9	19(4) 25(5)	1.5	4	15		●	●	●	●	●	●	
13 / (7)	17	5.0-12.9	19(4) 25(5)	1.5	4	15		●	●	●	●	●	●	●
16 / (8)	20	8.0-15.9	19(4) 25(5)	1.5	4	15		●	●	●	●	●	●	●
20 / (9)	25	12.0-19.9	19(4) 25(5)	1.5	4	15		●	●	●	●	●	●	●

Ordering Code (example):

2216.7G4.0720

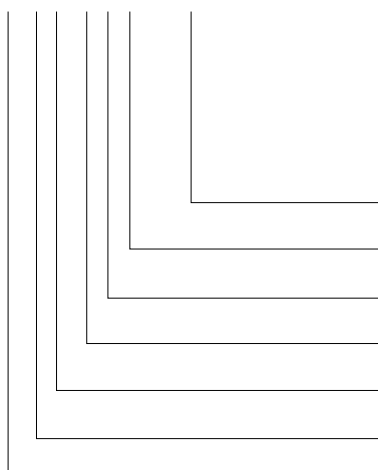

Shape: round
P = ø7,2 mm
Punch cutting length: l₁
19 mm
Length: l
100 mm
Diameter: d₁
13 mm
Type:
with tapered head
Execution:
round
Punch:
without ejector pin

= 0720
Order No
= (4)
Order Code character
= (G)
Order No
= (7)
Order No
= (6)
Order No
= (1)
= 22

Material:

HSS
Hardness:
Shaft 62-66 HRC
Head 45-55 HRC

☞ Description of FIBRO materials for tool and die components see at the beginning of Chapter E.

Execution:

Shaft precision ground. Head subsequently hot upset-forged and tempered.

Note:

Matching piloted counterbore 2284.00.
Matching retainer ring 2284.00.01.

PUNCH WITH TAPERED HEAD, BLANK, WITH EJECTOR PIN, DIN 5118 SHAPE E



2706.

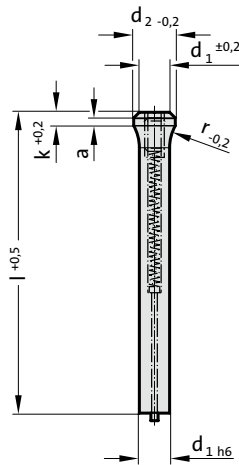

2706. Punch with tapered head, blank, with ejector pin, DIN 5118 Shape E

d ₁ / Order No	d ₂	a	k	r	l (Order Code character)	71 (D)	80 (E)	90 (F)	100 (G)	120 (J)
5 / (3)	7	1.5	4	10		●	●	●	●	●
6 / (4)	9	1.5	4	10		●	●	●	●	●
8 / (5)	11	1.5	4	12		●	●	●	●	●
10 / (6)	14	1.5	4	15		●	●	●	●	●
13 / (7)	17	1.5	4	15		●	●	●	●	●
16 / (8)	20	1.5	4	15		●	●	●	●	●
20 / (9)	25	1.5	4	15		●	●	●	●	●

Material:

HSS

Hardness:

Shaft 62-66 HRC

Head 45-55 HRC

Description of FIBRO materials for tool and die components see at the beginning of Chapter E.

Execution:

Shaft precision ground. Head subsequently hot upset-forged and tempered.

Note:

Matching piloted counterbore 2284.00.

Matching retainer ring 2284.00.01.

Ordering Code (example):

2706.7G

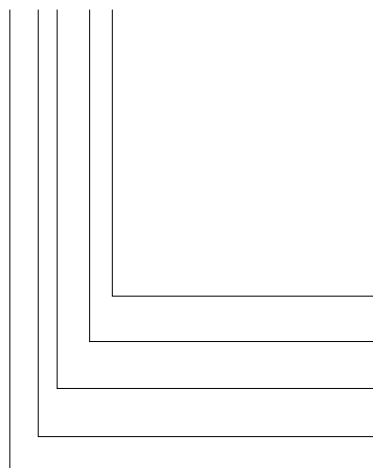

Length: l
100 mm
Diameter: d₁
13 mm
Type:
with tapered head
Execution:
blank
Punch:
with ejector pin

Order Code character
= (G)
Order No
= (7)
Order No
= (6)
Order No
= (0)
= 27

PUNCH WITH TAPERED HEAD, STEPPED, ROUND, WITH EJECTOR PIN, DIN 5118 SHAPE F



2716.

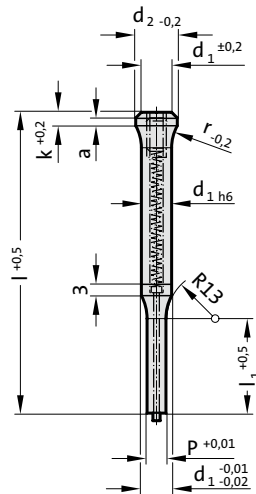

2716. Punch with tapered head, stepped, round, with ejector pin, DIN 5118 Shape F

d ₁ / Order No	d ₂	p	l ₁ / Order No	a	k	r	l (Order Code character)	71 (D)	80 (E)	90 (F)	100 (G)	120 (J)
5 / (3)	7	1.6-4.9	13 (3) 19 (4)	1.5	4	10		●	●	●	●	●
6 / (4)	9	2.5-5.9	13 (3) 19 (4)	1.5	4	10		●	●	●	●	●
8 / (5)	11	2.5-7.9	19 (4) 25 (5)	1.5	4	12		●	●	●	●	●
10 / (6)	14	4.0-9.9	19 (4) 25 (5)	1.5	4	15		●	●	●	●	●
13 / (7)	17	5.0-12.9	19 (4) 25 (5)	1.5	4	15		●	●	●	●	●
16 / (8)	20	8.0-15.9	19 (4) 25 (5)	1.5	4	15		●	●	●	●	●
20 / (9)	25	12.0-19.9	19 (4) 25 (5)	1.5	4	15		●	●	●	●	●

Ordering Code (example):

2716.7G4.0720

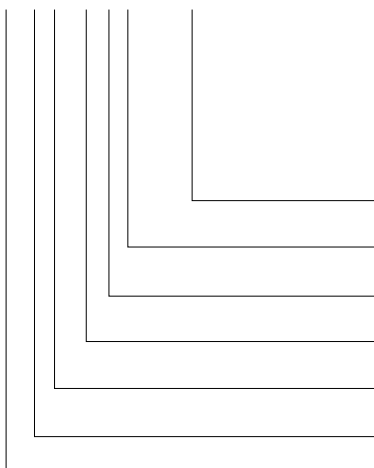

Shape: round

P = ø7,2 mm

Punch cutting length: l₁
19 mm

Length: l
100 mm

Diameter: d₁
13 mm

Type:
with tapered head

Execution:
round

Punch:
with ejector pin

= 0720

Order No
= (4)

Order Code character
= (G)

Order No
= (7)

Order No
= (6)

Order No
= (1)

= 27

Material:

HSS

Hardness:

Shaft 62-66 HRC

Head 45-55 HRC

Description of FIBRO materials for tool and die components see at the beginning of Chapter E.

Execution:

Shaft precision ground. Head subsequently hot upset-forged and tempered.

Note:

Matching piloted counterbore 2284.00.

Matching retainer ring 2284.00.01.

MOUNTING RING FOR PUNCH WITH TAPERED HEAD

2284.00.01.

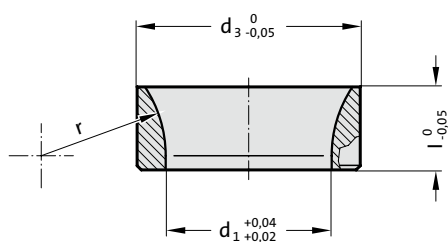

2284.00.01. Mounting ring for punch with tapered head

Order No	d ₁	d ₂	d ₃	d ₄	l	l ₁	r
2284.00.01.0300	3	4.5	5.9	6	4	7	6.5
2284.00.01.0400	4	5.5	6.9	7	4	8	8
2284.00.01.0500	5	7	8.9	9	7	11	10
2284.00.01.0600	6	9	10.9	11	7	11	10
2284.00.01.0800	8	11	12.9	13	8	12	12
2284.00.01.1000	10	14	15.9	16	9	13	15
2284.00.01.1300	13	17	18.9	19	9	13	15
2284.00.01.1600	16	20	21.9	22	9	13	15
2284.00.01.2000	20	25	26.9	27	10	14	15

Mounting example

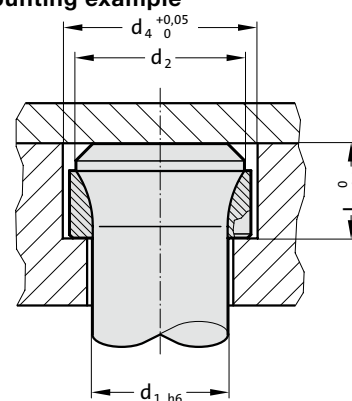

Material:

Tool steel, heat-treated

Note:

Used for punch with tapered neck

Assembly Guide Lines for Head Type Punches with Round Points

Description:

Head type punches with round point (DIN 9844) are intended for floating assembly in the punch retainer. Radial guiding is to be provided by the stripper.

This type of punch assembly eliminates alignment errors caused by distorted mounting of the die set and faulty press geometry.

With punches held in this manner, a clear separation between transmission of perforation force and guiding is achieved.

In order to facilitate assembly of punches of different diameters, the height of the heads is standardized to $4_{+0,2}$ mm (DIN 9844).

Guide Lines:

(excerpts from DIN 9844, page 5)

d_1 max. = stock thickness

stripping force*, for d_1 from 1 to 5 mm: approx. 20 % of piercing force
ditto . . . , for d_1 from 5 to 16 mm: approx. 10 % of piercing force

*applicable to stock not exceeding 400 N/mm² shear strength

Punch retainer: steel of at least 300 N/mm² tensile strength

Retaining hole in punch retainer = 1,05 times d_1 or d_2 respectively

Clearance punch head/percussion plate = 0,02 mm.

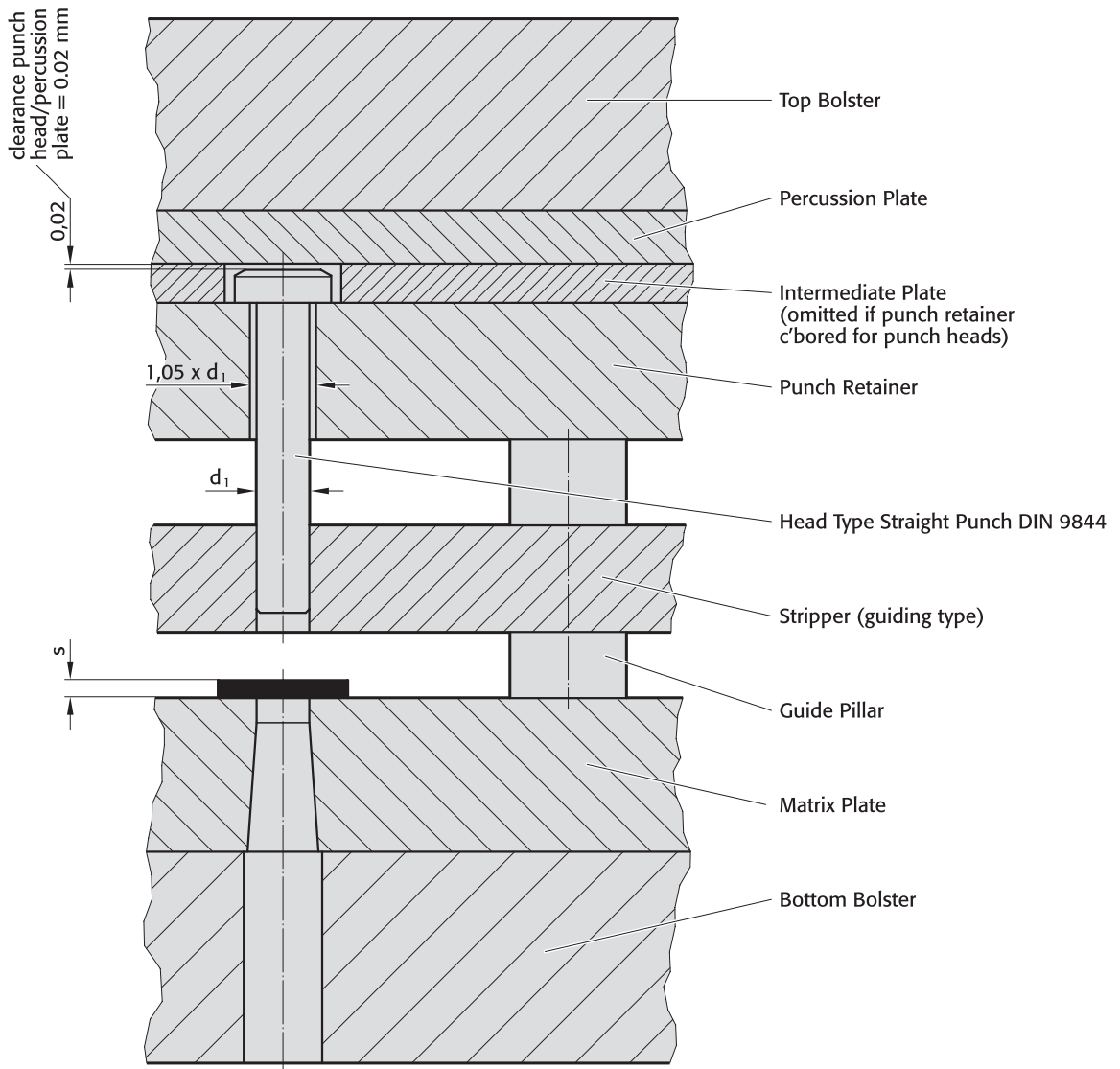

Punch DIN 9844, Shape A

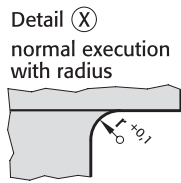

220.

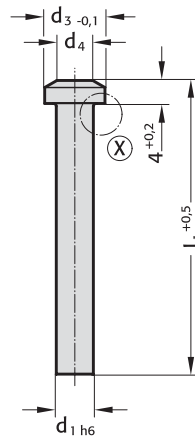

$$d_4 = d_1^{+0,5}$$



Material:

HSS
Order No 220.3.
Hardness:
Shaft 64 ± 2 HRC
Head 52 ± 3 HRC

HST
Order No 220.4.
Hardness:
Surface ≥ 950 HV 0,3
Head 52 ± 3 HRC

Description of FIBRO materials for tool and die components see at the beginning of Chapter E.

Execution:

Punch head hot upset-forged.
Shaft and shoulder precision plunge-ground.

Stock lengths: 71, 90, 112 mm.
other lengths and diameters on request!

220. Punch DIN 9844, Shape A

Gradation								
d_1	d_1	d_3	r	l_1	71	90	112	
2 - 2.2	0.1	3.6	0.2		●	●	●	
2.3 - 2.5	0.1	4	0.2		●	●	●	
2.6 - 2.8	0.1	4.5	0.3		●	●	●	
2.9 - 3.2	0.1	5	0.3		●	●	●	
3.3 - 3.5	0.1	6	0.3		●	●	●	
3.6 - 4	0.1	7	0.3		●	●	●	
4.1 - 4.5	0.1	8	0.5		●	●	●	
4.6 - 5	0.1	8.5	0.5		●	●	●	
5.1 - 5.4	0.1	9	0.5		●	●	●	
5.5 - 5.9	0.1	9.5	0.5		●	●	●	
6 - 6.4	0.1	10	0.5		●	●	●	
6.5 - 7	0.5	10.8	0.7		●	●	●	
7.5 - 8	0.5	12	0.7		●	●	●	
8.5 - 9	0.5	13	0.7		●	●	●	
9.5 - 10	0.5	14.5	0.7		●	●	●	
10.5 - 11	0.5	16	1		●	●	●	
11.5 - 12.5	0.5	18	1		●	●	●	
13 - 14.5	0.5	20	1		●	●	●	
15 - 16	0.5	22	1		●	●	●	

Ordering Code (example):

Punch DIN 9844, Shape A	= 220.
Material MAT	HSS = 3.
Cutting diameter d_1	2 mm = 0200.
Length l_1	71 mm = 071
Order No	= 220. 3. 0200. 071

Punch DIN 9844, Shape B

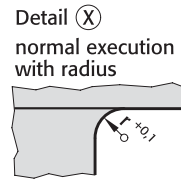
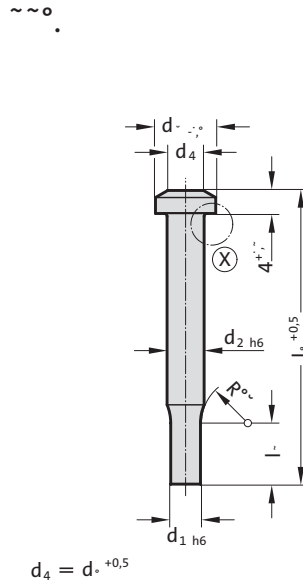

221. Punch DIN 9844, Shape B

Gradation		d_1	d_2	d_3	l_2	r	l_1	71	90	112
0.1 - 1.9	0.05	2	3.6	7	0.2			●	●	●
1.95 - 2.4	0.05	2.5	4	7	0.2			●	●	●
2.5 - 3.1	0.1	3.2	5	7	0.3			●	●	●
3.2 - 3.9	0.1	4	7	7	0.3			●	●	●
4 - 4.9	0.1	5	8.5	7	0.5			●	●	●
5 - 6.2	0.1	6.3	10	7	0.5			●	●	●
6.3 - 7.9	0.1	8	12	16	0.7			●	●	●
8 - 9.9	0.1	10	14.5	16	0.7			●	●	●
10 - 12.4	0.1	12.5	18	16	1			●	●	●
12.5 - 15.9	0.1	16	22	16	1			●	●	●

Material:

HSS
Order No 221.3.
Hardness:
Shaft 64 ± 2 HRC
Head 52 ± 3 HRC

HST
Order No 221.4.
Hardness:
Surface ≥ 950 HV 0,3
Head 52 ± 3 HRC

Description of FIBRO materials for tool and die components see at the beginning of Chapter E.

Execution:

Punch head hot upset-forged.
Shaft and shoulder precision plunge-ground.

Stock lengths: 71, 90, 112 mm.
other lengths and diameters on request!

Ordering Code (example):

Punch DIN 9844, Shape B	= 221.
Material MAT	HSS = 3.
Cutting diameter d_1	0.1 mm = 0010.
Length l_1	71 mm = 071
Order No	= 221. 3. 0010. 071

Punch similar to VDI 3374



266.

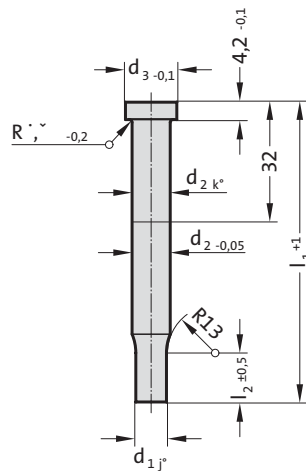

Material:

HSS
 Order No 266.3.
 Hardness:
 Shaft 62 ± 2 HRC
 Head 45 ± 5 HRC

Description of FIBRO materials for tool and die components see at the beginning of Chapter E.

Execution:

Punch head hot upset-forged.
 Shaft and shoulder precision plunge-ground.

Stock lengths: 71, 80 mm.
 other lengths and diameters on request!

266. Punch similar to VDI 3374

d ₁	Gradation		d ₂	d ₃	l ₂	l ₁ ⁺¹	71	80
	d ₁							
5 - 8.9	0.1		10	13	13		●	●
9 - 11.9	0.1		13	16	13		●	●
12 - 15.9	0.1		16	19	13		●	●
16 - 19.5	0.5		20	24	13		●	●
20 - 24.5	0.5		25	29	13		●	●

Ordering Code (example):

Punch similar to VDI 3374	=266.
Material MAT	HSS = 3.
Cutting diameter d ₁	5 mm = 0500.
Length l ₁	71 mm = 071
Order No	=266. 3.0500. 071

Punch with ejector pin



267.

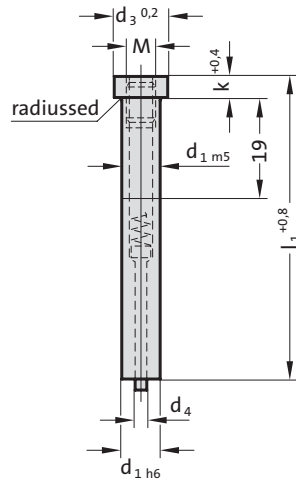

267. Punch with ejector pin

d_{1h6}	d_3	d_4	k	l_1	l_1	l_1	l_1	M
5	8	0.45	5	●	●			M2.5
6	9	0.7	5	●	●	●	●	M3
8	11	1.04	5	●	●	●	●	M4
10	13	1.47	5	●	●	●	●	M5
13	16	1.47	5	●	●	●	●	M5
16	19	2.26	6.4	●	●	●	●	M6
20	23	2.26	6.4	●	●	●	●	M6
25	28	2.26	6.4	●	●	●	●	M6

Material:

HSS
 Order No 267.3.
 Hardness:
 Shaft 64 ± 2 HRC
 Head 52 ± 3 HRC

Description of FIBRO materials for tool and die components see at the beginning of Chapter E.

Execution:

Punch head hot upset-forged.
 Shaft and shoulder precision plunge-ground.

Ordering Code (example):

Punch with ejector pin	= 267.
Material MAT	HSS = 3.
Shaft diameter d_1	5 mm = 0500.
Length l_1	60 mm = 060
Order No	= 267. 3.0500. 060



Punch with ejector pin, stepped, short point

268.

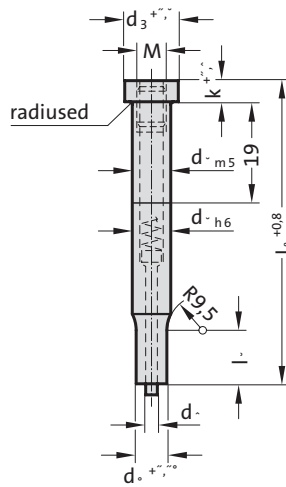
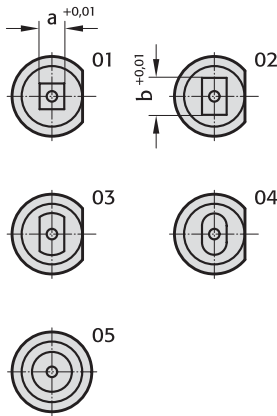

Material:

HSS
 Order No 268.3.
 Hardness:
 Shaft 64 ± 2 HRC
 Head 52 ± 3 HRC

Description of FIBRO materials for tool and die components see at the beginning of Chapter E.

Execution:

Punch head hot upset-forged.
 Shaft and shoulder precision plunge-ground.

Key flats parallel with longest size of shape, unless otherwise specified.

268. Punch with ejector pin, stepped, short point

d ₁	d ₂	d ₃	d ₄	k	l ₂	l ₁	l ₁	l ₁	l ₁	a _{min}	M
1.6 - 4.9	5	8	0.45	5	7	●	●			1.6	M2.5
2.3 - 5.9	6	9	0.7	5	7	●	●	●	●	2.3	M3
3.2 - 7.9	8	11	1.04	5	13	●	●	●	●	3.2	M4
4.8 - 9.9	10	13	1.47	5	13	●	●	●	●	4.8	M5
4.8 - 12.9	13	16	1.47	5	13	●	●	●	●	4.8	M5
5.5 - 15.9	16	19	2.26	6.4	13	●	●	●	●	5.5	M6
5.5 - 19.9	20	23	2.26	6.4	13	●	●	●	●	5.5	M6
6.5 - 24.9	25	28	2.26	6.4	13	●	●	●	●	6.5	M6

Ordering Code (example):

Punch with ejector pin, stepped, short point	=268.3.
Shaft diameter d ₂	5 mm = 0500.
Length l ₁	60 mm = 060.
Die shape FORM	Square = 01.
Die shape width a	1.6 mm = 0160.
Die shape length b	1.6 mm = 0160.
Order No	=268.3. 0500. 060. 01. 0160. 0160

Punch with ejector pin, stepped, long point



269.

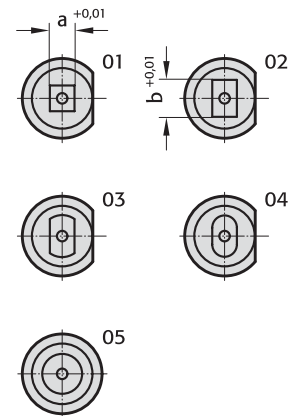
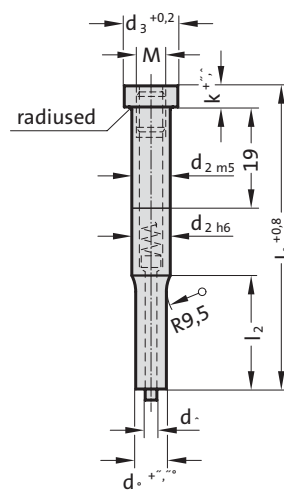

269. Punch with ejector pin, stepped, long point

d ₁	d ₂	d ₃	d ₄	k	l ₂	l ₁	l ₁	l ₁	l ₁	a _{min}	M
2.3 - 5.9	6	9	0.7	5	17.5	60	71	80	90	2.3	M3
3.2 - 7.9	8	11	1.04	5	25	●	●	●	●	3.2	M4
4.8 - 9.9	10	13	1.47	5	28	●	●	●	●	4.8	M5
4.8 - 12.9	13	16	1.47	5	28	●	●	●	●	4.8	M5
5.5 - 15.9	16	19	2.26	6.4	28	●	●	●	●	5.5	M6
5.5 - 19.9	20	23	2.26	6.4	28	●	●	●	●	5.5	M6
6.5 - 24.9	25	28	2.26	6.4	28	●	●	●	●	6.5	M6

Material:

HSS
 Order No 269.3.
 Hardness:
 Shaft 64 ± 2 HRC
 Head 52 ± 3 HRC

Description of FIBRO materials for tool and die components see at the beginning of Chapter E.

Execution:

Punch head hot upset-forged.
 Shaft and shoulder precision plunge-ground.

Key flats parallel with longest size of shape, unless otherwise specified.

Ordering Code (example):

Punch with ejector pin, stepped, long point	= 269.3.
Shaft diameter d ₂	6 mm = 0600.
Length l ₁	60 mm = 060.
Die shape FORM	Square = 01.
Die shape width a	2.3 mm = 0230.
Die shape length b	2.3 mm = 0230
Order No	= 269.3. 0600. 060. 01. 0230. 0230

Sintered Hard Metal HIP-densified

The HIP process (hot isostatic pressing) consists of a special densification treatment.

Applied after the sintering stage, this widely used process involves compacting, at very high temperature and pressure, of the carbide structure. It yields an appreciable reduction in porosity, better strength properties and thus longer die life of press tool members.

As can be seen from the diagrams and tables, both compressive and flexural strength are improved.

For stamping die tooling, hard metal types of medium tungsten particle size, with a cobalt content of 9 to 12%, have been found successful in a wide field of applications.

Tensile strength of Tungsten – 6% Cobalt Carbide in the sintered-only versus HIP-densified state, in dependence of Crystallite particle size

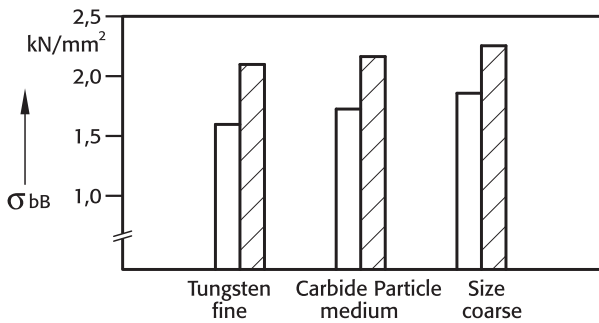

a) influence of crystallite size of hard metal phase
(left: sintered only – right: sintered and HIP-treated)

Tensile strength of Tungsten – Cobalt Carbide in the sintered-only versus HIP-densified state, in dependence of total Cobalt content

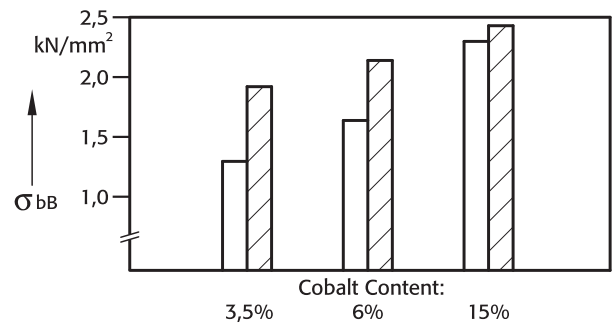

b) influence of cobalt content
Porosity in the sintered-only state: $\geq A1$
(left: sintered only – right: sintered and HIP-treated)

Flexural strength and HV30-hardness of Tungsten-Cobalt Carbides with/without HIP-treatment and in dependence of Tungsten Carbide particle size and Cobalt content.

Change of Sintered Hard Metal by hot isostatic pressing

Tungsten carbide – particle size	Co %	HV ₃₀ -Hardness		Flexural Strength N/mm ²	
		befor	after	befor	after
fine	3	1800	no changes	1200	1700
	6	1650		1500	2300
	9	1400		2000	2600
medium	6	1600	no changes	2000	2600
	9	1450		2350	2700
	12	1300		2450	2900
coarse	15	1200	no changes	2700	2850
	6	1400		1900	2250
	8	1350		2300	2600
	10	1200		2650	2850

Punch similar DIN 9844, Shape A



270.

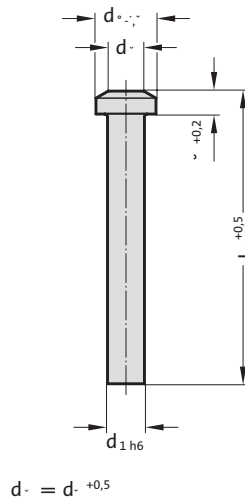

Material:

Tungsten-Cobalt-Carbide
Order No 270.9.

Execution:

Shaft precision ground.
Head: Steel, brazed to shaft or Tungsten-Cobalt Carbide.

Other diameters and lengths on request.

270. Punch similar DIN 9844, Shape A

d ₁	Gradation			l ₁	71	90	112
	d ₁	d ₃	r				
1 - 2.2	0.1	3.6	0.2		●	●	●
2.3 - 2.5	0.1	4	0.2		●	●	●
2.6 - 2.8	0.1	4.5	0.3		●	●	●
2.9 - 3.2	0.1	5	0.3		●	●	●
3.3 - 3.5	0.1	6	0.3		●	●	●
3.6 - 4	0.1	7	0.3		●	●	●
4.1 - 4.5	0.1	8	0.5		●	●	●
4.6 - 5	0.1	8.5	0.5		●	●	●
5.1 - 5.4	0.1	9	0.5		●	●	●
5.5 - 5.9	0.1	9.5	0.5		●	●	●
6 - 6.4	0.1	10	0.5		●	●	●
6.5 - 7	0.5	10.8	0.7		●	●	●
7.5 - 8	0.5	12	0.7		●	●	●
8.5 - 9	0.5	13	0.7		●	●	●
9.5 - 10	0.5	14.5	0.7		●	●	●
10.5 - 11	0.5	16	1		●	●	●
11.5 - 12.5	0.5	18	1		●	●	●
13 - 14.5	0.5	20	1		●	●	●
15 - 16	0.5	22	1		●	●	●

Ordering Code (example):

Punch similar DIN 9844, Shape A	= 270.9.
Shaft diameter d ₁	1 mm = 0100.
Length l ₁	71 mm = 071
Order No	= 270.9. 0100. 071

Punch similar DIN 9844, Shape B

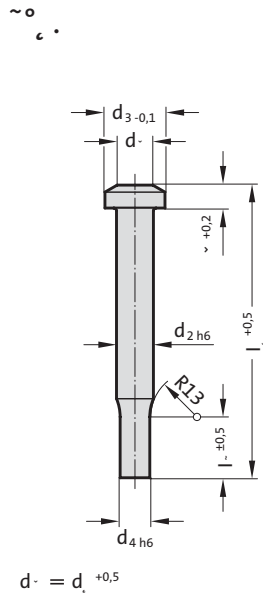

271. Punch similar DIN 9844, Shape B

Gradation		d_1	d_2	d_3	l_2	r	l_1	71	90	112
0.5 - 1.9	0.05	2	3.6	7	0.2		●	●	●	
1.95 - 2.4	0.05	2.5	4	7	0.2		●	●	●	
2.5 - 3.1	0.1	3.2	5	7	0.3		●	●	●	
3.2 - 3.9	0.1	4	7	7	0.3		●	●	●	
4 - 4.9	0.1	5	8.5	7	0.5		●	●	●	
5 - 6.2	0.1	6.3	10	7	0.5		●	●	●	
6.3 - 7.9	0.1	8	12	16	0.7		●	●	●	
8 - 9.9	0.1	10	14.5	16	0.7		●	●	●	
10 - 12.4	0.1	12.5	18	16	1		●	●	●	
12.5 - 15.9	0.1	16	22	16	1		●	●	●	

Material:
Tungsten-Cobalt-Carbide
Order No 271.9.

Execution:
Shaft precision ground.
Head: Steel, brazed to shaft or Tungsten-Cobalt Carbide.

Other diameters and lengths on request.

Ordering Code (example):

Punch similar DIN 9844, Shape B	= 271.9.
Cutting diameter d_1	0.5 mm = 0050.
Length l_1	71 mm = 071
Order No	= 271.9. 0050. 071

Punch similar DIN 9861, Shape D

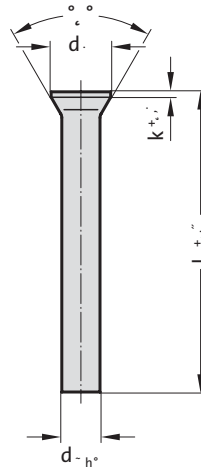

Material:

Tungsten-Cobalt-Carbide
Order No 272.9.

Execution:

Shaft precision ground.
Head: Steel, brazed to shaft or Tungsten-Cobalt Carbide.

Other diameters and lengths on request.

272. Punch similar DIN 9861, Shape D

		Gradation					
d ₁	d ₁	d ₂	k	l ₁	71	80	100
1.5	0.1	2.2	0.5		●	●	●
1.6 - 1.7	0.1	2.5	0.5		●	●	●
1.8 - 1.9	0.1	2.8	0.5		●	●	●
2	0.1	3	0.5		●	●	●
2.1 - 2.2	0.1	3.2	0.5		●	●	●
2.3 - 2.5	0.1	3.5	0.5		●	●	●
2.6 - 2.9	0.1	4	0.5		●	●	●
3 - 3.4	0.1	4.5	0.5		●	●	●
3.5 - 3.9	0.1	5	0.5		●	●	●
4 - 4.4	0.1	5.5	0.5		●	●	●
4.5 - 4.9	0.1	6	0.5		●	●	●
5 - 5.4	0.1	6.5	0.5		●	●	●
5.5 - 5.9	0.1	7	0.5		●	●	●
6 - 6.4	0.1	8	0.5		●	●	●
6.5 - 7	0.5	9	1		●	●	●
7.5 - 8	0.5	10	1		●	●	●
8.5 - 9	0.5	11	1		●	●	●
9.5 - 10	0.5	12	1		●	●	●
10.5 - 11	0.5	13	1		●	●	●
11.5 - 12	0.5	14	1		●	●	●
12.5 - 13	0.5	15	1		●	●	●
13.5 - 14	0.5	16	1.5		●	●	●
14.5 - 15	0.5	17	1.5		●	●	●
15.5 - 16	0.5	18	1.5		●	●	●

Ordering Code (example):

Punch similar DIN 9861, Shape D	= 272.9.
Shaft diameter d ₁	1.5 mm = 0150.
Length l ₁	71 mm = 071
Order No	= 272.9. 0150. 071

Punch similar DIN 9861, Shape C



273.

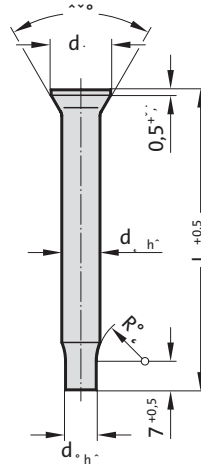

273. Punch similar DIN 9861, Shape C

d_1	Gradation	d_2	d_3	l_1
0.5 - 1.5	0.05	3	2	71
1.55 - 2.95	0.05	4.5	3	71

Material:

Tungsten-Cobalt-Carbide
Order No 273.9.

Execution:

Shaft precision ground.
Head: Steel, brazed to shaft or Tungsten-Cobalt Carbide.

Other diameters and lengths on request.

Ordering Code (example):

Punch similar DIN 9861, Shape C	= 273.9.
Cutting diameter d_1	0.5 mm = 0050.
Length l_1	71 mm = 071
Order No	= 273.9. 0050. 071



Ball-Lock Punches



Ordering example Ball-Lock Punches

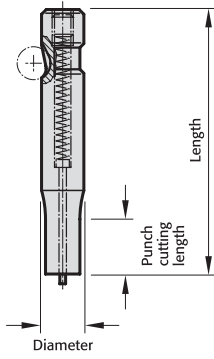

Note: See table for standard dimensions
Special dimensions to order

2 2 4 2 . 2 F 1 . 0 6 5 0 . 0 4 5 0 B

Punch:
22 without ejector pin
27 with ejector pin

Version:	Order No
○ blank	= 0
⊙ round	= 1
□ square	= 2
▭ rectangular	= 3
◻ slot	= 4
◻ rectangle with radiused corners	= 5
▽ pilot pin with tapered tip	= 6
∩ pilot pin parabolic tip	= 7
special shapes	= 9

Type:	Order No
light	= 2
heavy	= 3
punch larger, light	= 4
punch larger, heavy	= 5

Punch cutting length: l_1	Order No
13	= 1
19	= 2
25	= 3
30	= 4
special	= X

Format: Slot length P = 6,5 mm

Format: Slot width W = 4,5 mm

Length: l	Order Code character
50	= A
56	= B
63	= C
71	= D
80	= E
90	= F
100	= G
110	= H
125	= J
140	= K
150	= L
175	= M
200	= N
special	= X

Angle:	Order Code character
0°	= A
90°	= B
180°	= C
270°	= D
special	= X

Diameter: d_2	Order No
6 (light duty only)	= 1
10	= 2
13	= 3
16	= 4
20	= 5
25	= 6
32	= 7
38 (light duty only)	= 8
40 (heavy duty only)	= 9

Ordering Code (Example):

2 2 4 2 . 2 F 1 . 0 6 5 0 . 0 4 5 0 B

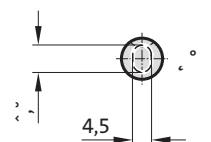
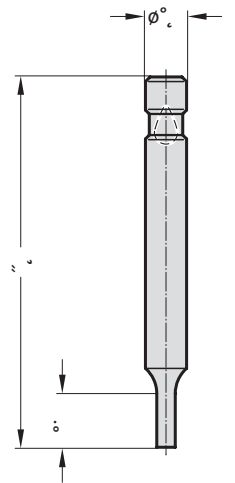
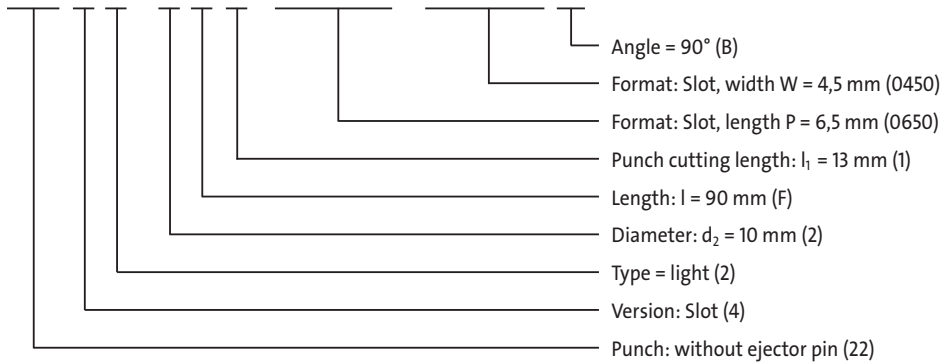

Ball lock punch, blank, light duty



2202.

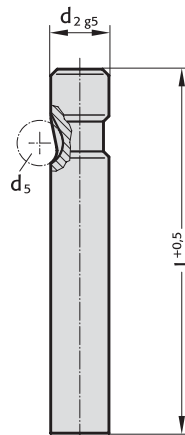

2202. Ball lock punch, blank, light duty

d ₂ / (Order No)	d ₅	l / (Order Code character)	63 (C)	71 (D)	80 (E)	90 (F)	100 (G)	110 (H)	125 (J)	140 (K)	150 (L)	175 (M)	200 (N)
6 / (1)	6		●	●	●	●	●	●	●	●	●	●	●
10 / (2)	8		●	●	●	●	●	●	●	●	●	●	●
13 / (3)	8		●	●	●	●	●	●	●	●	●	●	●
16 / (4)	8		●	●	●	●	●	●	●	●	●	●	●
20 / (5)	8		●	●	●	●	●	●	●	●	●	●	●
25 / (6)	8		●	●	●	●	●	●	●	●	●	●	●
32 / (7)	8		●	●	●	●	●	●	●	●	●	●	●
38 / (8)	8		●	●	●	●	●	●	●	●	●	●	●

Ordering code (example):

2202.7G

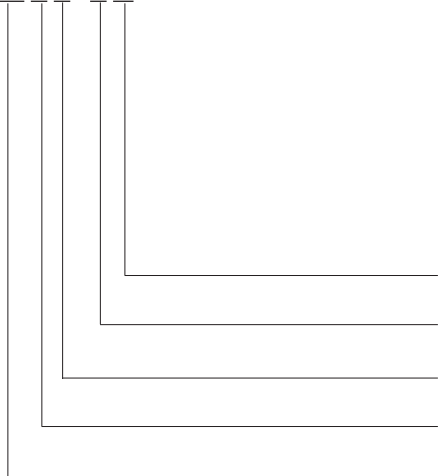

Length: l
100 mm
Diameter: d₂
32 mm
Type:
light
Version:
blank
Punch:
without ejector pin

Order Code character
= (G)
Order No
= (7)
Order No
= (2)
Order No
= (0)

Material:

HSS
Hardness 62 ± 2 HRC

Execution:

Shaft fine ground.
Special dimensions on request.

Ball lock punch, stepped, round, light duty

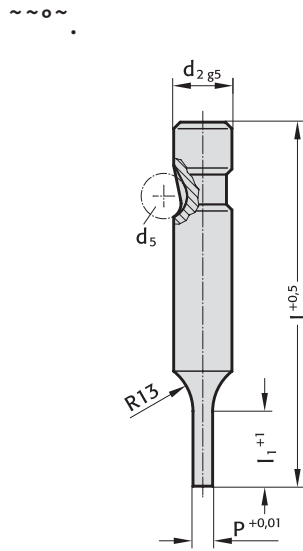

2212. Ball lock punch, stepped, round, light duty

d ₂ / (Order No)	d ₅	P	l ₁ / (Order No)*	l / (Order Code character)	63 (C)	71 (D)	80 (E)	90 (F)	100 (G)
6 / (1)	6	1,6-5,9	13 (1)		●	●	●	●	●
10 / (2)	8	1,6-9,9	13 (1) 19 (2)		●	●	●	●	●
13 / (3)	8	5,0-12,9	13 (1) 19 (2)		●	●	●	●	●
16 / (4)	8	8,0-15,9	13 (1) 19 (2) 25 (3)		●	●	●	●	●
20 / (5)	8	12,0-19,9	13 (1) 19 (2) 25 (3)		●	●	●	●	●
25 / (6)	8	16,0-24,9	13 (1) 19 (2) 25 (3)		●	●	●	●	●
32 / (7)	8	24,0-31,9	13 (1) 19 (2) 25 (3)			●	●	●	●
38 / (8)	8	30,0-37,9	19 (2) 25 (3) 30 (4)				●	●	●

*l₁=10 where P < 2.20

Material:

HSS
Hardness 62 ± 2 HRC

Execution:

Shaft and punch diameter fine ground.
Special dimensions on request.

Ordering-code (example):

2 2 1 2 . 7 G 2 . 2 4 5 0

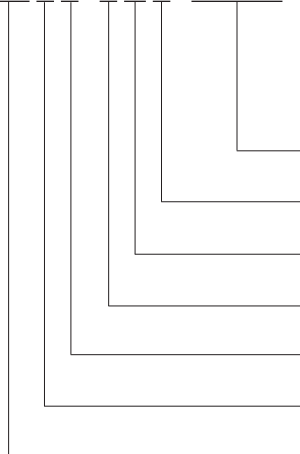

Format: Round
P = ø24,5 mm
Punch cutting length: l₁
19 mm
length: l
100 mm
diameter: d₂
32 mm
Type:
light
Version:
Round
Punch:
without ejector pin

= 2450
Order No
= (2)
Order code character
= (G)
Order No
= (7)
Order No
= (2)
Order No
= (1)
= 22



Ball lock punch, stepped, square, light duty

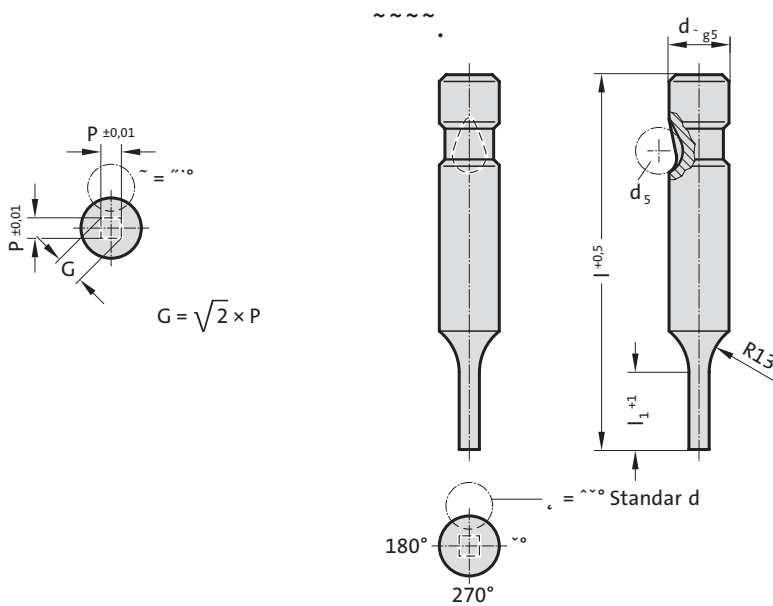

2222. Ball lock punch, stepped, square, light duty

d_2 / (Order No)	d_5	P_{min}	G_{max}	l_1 / (Order No)*	l / (Order Code character)	63 (C)	71 (D)	80 (E)	90 (F)	100 (G)
6 / (1)	6	1.6	5.9	13 (1)		●	●	●	●	●
10 / (2)	8	1.6	9.9	13 (1) 19 (2)		●	●	●	●	●
13 / (3)	8	4.5	12.9	13 (1) 19 (2)		●	●	●	●	●
16 / (4)	8	6	15.9	13 (1) 19 (2) 25 (3)		●	●	●	●	●
20 / (5)	8	8	19.9	13 (1) 19 (2) 25 (3)		●	●	●	●	●
25 / (6)	8	10	24.9	13 (1) 19 (2) 25 (3)		●	●	●	●	●
32 / (7)	8	12.5	31.9	13 (1) 19 (2) 25 (3)		●	●	●	●	●
38 / (8)	8	14	37.9	19 (2) 25 (3) 30 (4)		●	●	●	●	●

* $l_1=10$ where $P < 2.20$

Ordering-code (example):

2 2 2 2 . 2 F 1 . 0 6 5 0 B

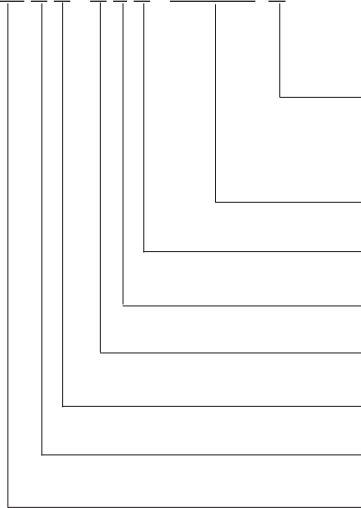

Angle:
 90°

Format: Square, length P

$P = 6,5$ mm

Punch cutting length: l_1

13 mm

Length: l

90 mm

Diameter: d_2

10 mm

Type:

light

Version:

Square

Punch:

without ejector pin

Order code character
= (B)

= 0650

Order No

= (1)

Order code character

= (F)

Order No

= (2)

Order No

= (2)

Order No

= (2)

= 22

Material:

HSS

Hardness 62 ± 2 HRC

Execution:

Shaft and punch shape fine ground.
Special dimensions on request.

Ball lock punch, stepped, rectangular, light duty



2232.

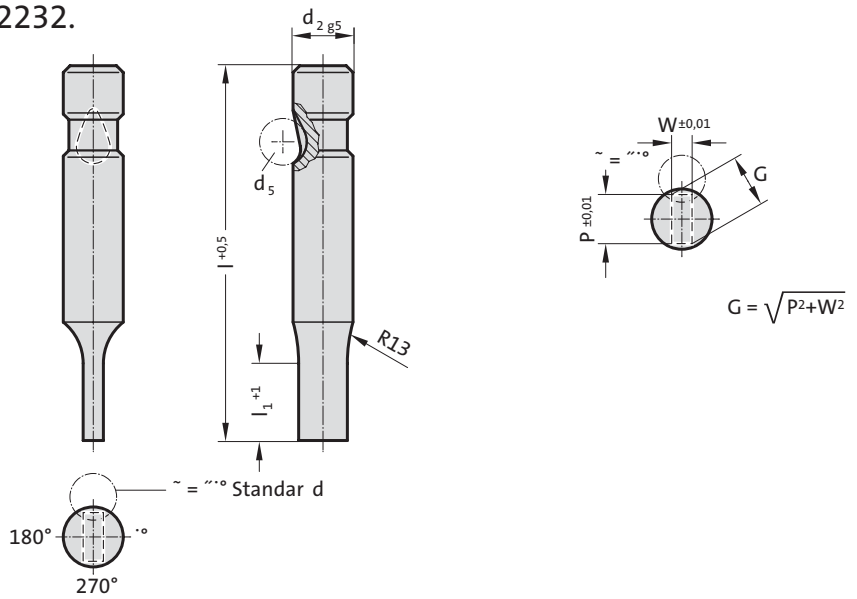

2232. Ball lock punch, stepped, rectangular, light duty

d ₂ / (Order No)	d ₅	W _{min}	G _{max}	l ₁ / (Order No)*	l / (Order Code character)	63 (C)	71 (D)	80 (E)	90 (F)	100 (G)
6 / (1)	6	1.6	5.9	13 (1)		●	●	●	●	●
10 / (2)	8	1.6	9.9	13 (1) 19 (2)		●	●	●	●	●
13 / (3)	8	4.5	12.9	13 (1) 19 (2)		●	●	●	●	●
16 / (4)	8	6	15.9	13 (1) 19 (2) 25 (3)		●	●	●	●	●
20 / (5)	8	8	19.9	13 (1) 19 (2) 25 (3)		●	●	●	●	●
25 / (6)	8	10	24.9	13 (1) 19 (2) 25 (3)		●	●	●	●	●
32 / (7)	8	12.5	31.9	13 (1) 19 (2) 25 (3)		●	●	●	●	●
38 / (8)	8	14	37.9	19 (2) 25 (3) 30 (4)		●	●	●	●	●

*l₁=10 where W < 2.20

Material:

HSS
Hardness 62 ± 2 HRC

Execution:

Shaft and punch shape fine ground.
Special dimensions on request.

Ordering-code (example):

2 2 3 2 . 2 F 1 . 0 6 5 0 . 0 4 5 0 B

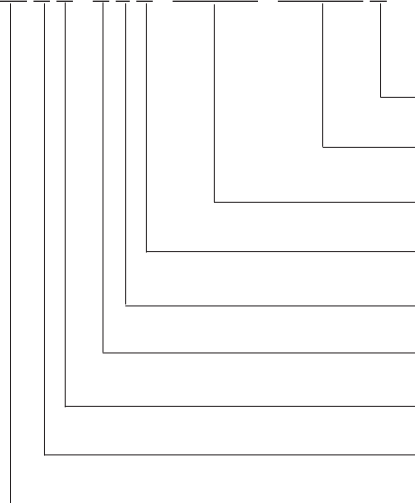

- Angle:** 90° **Order code character** = (B)
- Format:** Rectangular, width W
W = 4,5 mm **Order code character** = 0450
- Format:** Rectangular, length P
P = 6,5 mm **Order code character** = 0650
- Punch cutting length:** l₁
13 mm **Order No** = (1)
- Length:** l
90 mm **Order code character** = (F)
- Diameter:** d₂
10 mm **Order No** = (2)
- Type:** light **Order No** = (2)
- Version:** Rectangular **Order No** = (3)
- Punch:** without ejector pin **Order No** = 22



Ball lock punch, stepped, slot, light duty

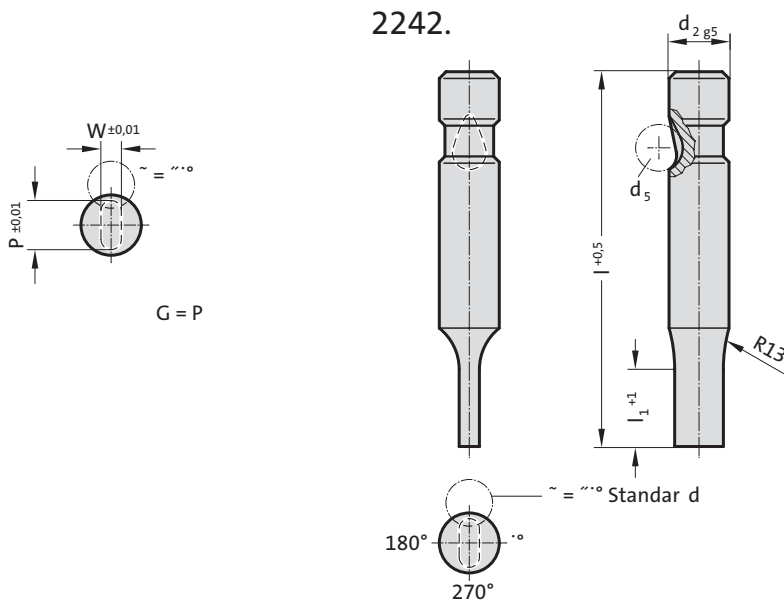

2242. Ball lock punch, stepped, slot, light duty

d ₂ / (Order No)	d ₅	W _{min}	G _{max}	l ₁ / (Order No)*	l / (Order Code character)	63 (C)	71 (D)	80 (E)	90 (F)	100 (G)
6 / (1)	6	1.6	5.9	13 (1)		●	●	●	●	●
10 / (2)	8	1.6	9.9	13 (1) 19 (2)		●	●	●	●	●
13 / (3)	8	4.5	12.9	13 (1) 19 (2)		●	●	●	●	●
16 / (4)	8	6	15.9	13 (1) 19 (2) 25 (3)		●	●	●	●	●
20 / (5)	8	8	19.9	13 (1) 19 (2) 25 (3)		●	●	●	●	●
25 / (6)	8	10	24.9	13 (1) 19 (2) 25 (3)		●	●	●	●	●
32 / (7)	8	12.5	31.9	13 (1) 19 (2) 25 (3)		●	●	●	●	●
38 / (8)	8	14	37.9	19 (2) 25 (3) 30 (4)				●	●	●

*l₁=10 where W < 2.20

Ordering-code (example):

22 42 . 2 F 1 . 0 6 5 0 . 0 4 5 0 B

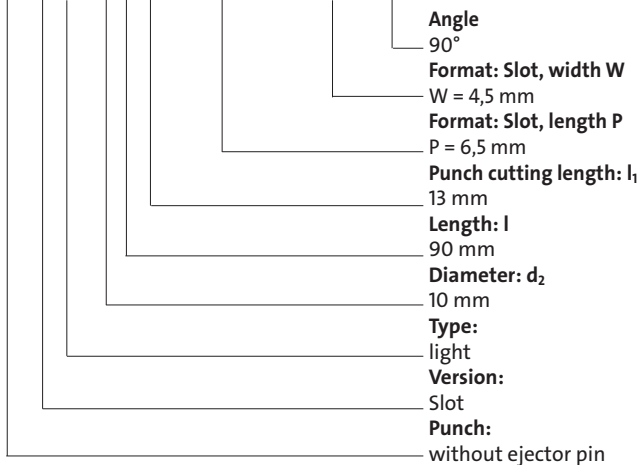

Order code character
 = (B)
 = 0450
 = 0650
Order No
 = (1)
Order code character
 = (F)
Order No
 = (2)
Order No
 = (2)
Order No
 = (4)
 = 22

Material:

HSS
 Hardness 62 ± 2 HRC

Execution:

Shaft and punch shape fine ground.
 Special dimensions on request.

Ball lock punch, stepped, rectangle with radiussed corners, light duty



2252.

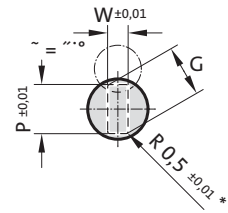
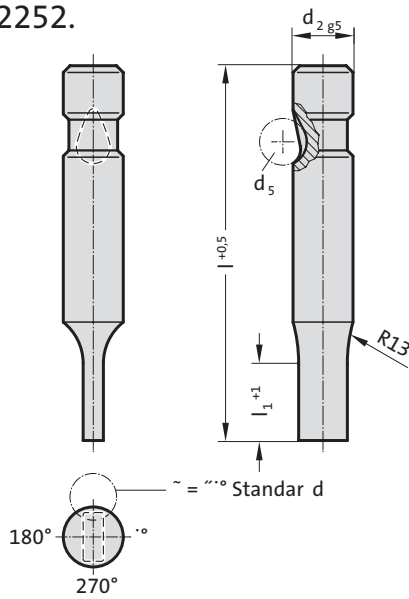

$$G = \sqrt{(P-1.0)^2 + (W-1.0)^2} + 1$$

2252. Ball lock punch, stepped, rectangle with radiussed corners, light duty

d ₂ / (Order No)	d ₅	W _{min}	G _{max}	l ₁ / (Order No)*	l / (Order Code character)	63 (C)	71 (D)	80 (E)	90 (F)	100 (G)
6 / (1)	6	1.6	5.9	13 (1)		●	●	●	●	●
10 / (2)	8	1.6	9.9	13 (1) 19 (2)		●	●	●	●	●
13 / (3)	8	4.5	12.9	13 (1) 19 (2)		●	●	●	●	●
16 / (4)	8	6	15.9	13 (1) 19 (2) 25 (3)		●	●	●	●	●
20 / (5)	8	8	19.9	13 (1) 19 (2) 25 (3)		●	●	●	●	●
25 / (6)	8	10	24.9	13 (1) 19 (2) 25 (3)		●	●	●	●	●
32 / (7)	8	12.5	31.9	13 (1) 19 (2) 25 (3)		●	●	●	●	●
38 / (8)	8	14	37.9	19 (2) 25 (3) 30 (4)		●	●	●	●	●

*l₁=10 where W < 2.20



Material:

HSS
Hardness 62 ± 2 HRC

Execution:

Shaft and punch shape fine ground.
Special dimensions on request.
* For other radius options, see standardised special shapes.

Ordering-code (example):

2 2 5 2 . 2 F 1 . 0 6 5 0 . 0 4 5 0 B

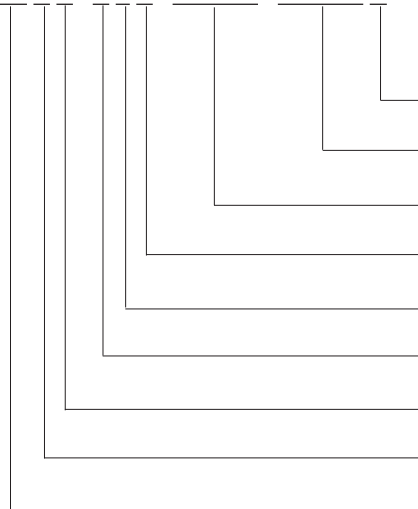

Angle: 90°
Order code character = (B)

Format: Rectangle with radiussed corners, width W
W = 4,5 mm = 0450

Format: Rectangle with radiussed corners, length P
P = 6,5 mm = 0650

Punch cutting length: l₁
13 mm = (1)

Length: l
90 mm = (F)

Diameter: d₂
10 mm = (2)

Type: light = (2)

Version: Rectangle with radiussed corners = (5)

Punch: without ejector pin = 22

Ball lock punch, blank, with ejector pin, light duty

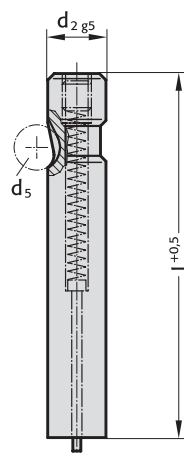

2702. Ball lock punch, blank, with ejector pin, light duty

d ₂ / (Order No)	d ₅	l / (Order Code character)	63 (C)	71 (D)	80 (E)	90 (F)	100 (G)
6 / (1)	6		●	●	●	●	●
10 / (2)	8		●	●	●	●	●
13 / (3)	8		●	●	●	●	●
16 / (4)	8		●	●	●	●	●
20 / (5)	8		●	●	●	●	●
25 / (6)	8		●	●	●	●	●
32 / (7)	8		●	●	●	●	●
38 / (8)	8		●	●	●	●	●

Ordering-code (example):

2702.7G

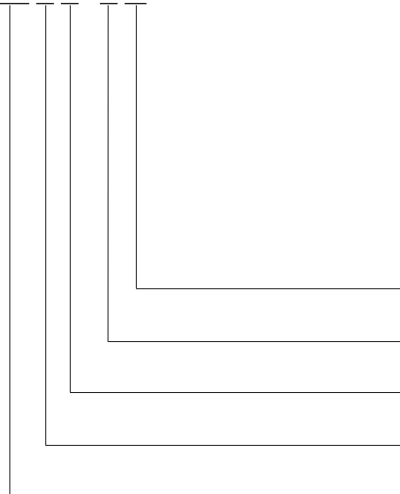

Length: l
100 mm
Diameter: d₂
32 mm
Type:
light
Version:
blank
Punch:
with ejector pin

Order code character
= (G)
Order No
= (7)
Order No
= (2)
Order No
= (0)
= 27

Material:

HSS
Hardness 62 ± 2 HRC

Execution:

Shaft fine ground.
Special dimensions on request.

Ball lock punch, stepped, round, with ejector pin, light duty

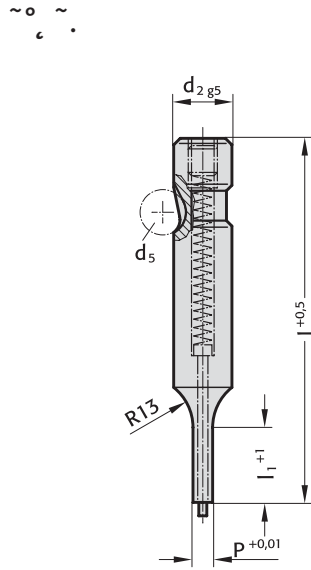

2712. Ball lock punch, stepped, round, with ejector pin, light duty

d ₂ / (Order No)	d ₅	P	l ₁ / (Order No)*	l / (Order Code character)	63 (C)	71 (D)	80 (E)	90 (F)	100 (G)
6 / (1)	6	1,6-5,9	13 (1)		●	●	●	●	●
10 / (2)	8	1,6-9,9	13 (1) 19 (2)		●	●	●	●	●
13 / (3)	8	5,0-12,9	13 (1) 19 (2)		●	●	●	●	●
16 / (4)	8	8,0-15,9	13 (1) 19 (2) 25 (3)		●	●	●	●	●
20 / (5)	8	12,0-19,9	13 (1) 19 (2) 25 (3)		●	●	●	●	●
25 / (6)	8	16,0-24,9	13 (1) 19 (2) 25 (3)		●	●	●	●	●
32 / (7)	8	24,0-31,9	13 (1) 19 (2) 25 (3)			●	●	●	●
38 / (8)	8	30,0-37,9	19 (2) 25 (3) 30 (4)				●	●	●

*l₁=10 where P < 2.20

Material:

HSS
Hardness 62 ± 2 HRC

Execution:

Shaft and punch diameter fine ground.
Special dimensions on request.

Ordering-code (example):

2 7 1 2 . 7 G 2 . 2 4 5 0

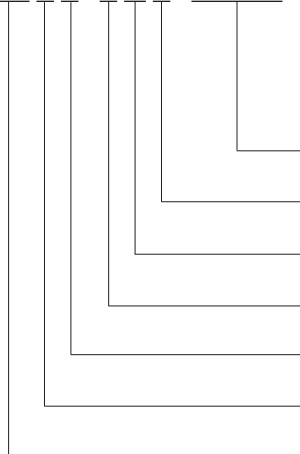

Format: Round
P = ø24,5 mm
Punch cutting length: l₁
19 mm
length: l
100 mm
diameter: d₂
32 mm
Type:
light
Version:
Round
Punch:
with ejector pin

= 2450
Order No
= (2)
Order code character
= (G)
Order No
= (7)
Order No
= (2)
Order No
= (1)
= 27



Ball lock punch, stepped, square, with ejector pin, light duty

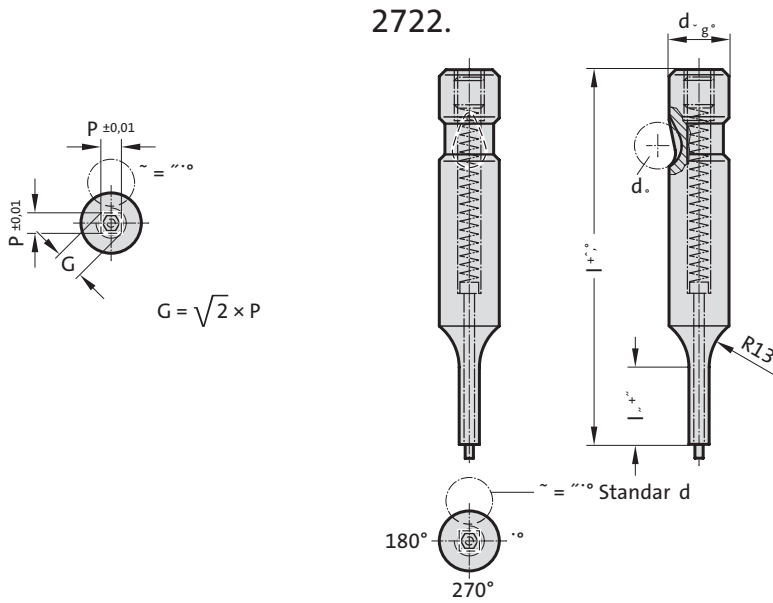

2722. Ball lock punch, stepped, square, with ejector pin, light duty

d ₂ / (Order No)	d ₅	P _{min}	G _{max}	l ₁ / (Order No)*	l / (Order Code character)	63 (C)	71 (D)	80 (E)	90 (F)	100 (G)
6 / (1)	6	1.6	5.9	13 (1)		●	●	●	●	●
10 / (2)	8	1.6	9.9	13 (1) 19 (2)		●	●	●	●	●
13 / (3)	8	4.5	12.9	13 (1) 19 (2)		●	●	●	●	●
16 / (4)	8	6	15.9	13 (1) 19 (2) 25 (3)		●	●	●	●	●
20 / (5)	8	8	19.9	13 (1) 19 (2) 25 (3)		●	●	●	●	●
25 / (6)	8	10	24.9	13 (1) 19 (2) 25 (3)		●	●	●	●	●
32 / (7)	8	12.5	31.9	13 (1) 19 (2) 25 (3)		●	●	●	●	●
38 / (8)	8	14	37.9	19 (2) 25 (3) 30 (4)		●	●	●	●	●

*l₁=10 where P < 2.20

Ordering-code (example):

27 22.2 E 1.0 6 5 0 A

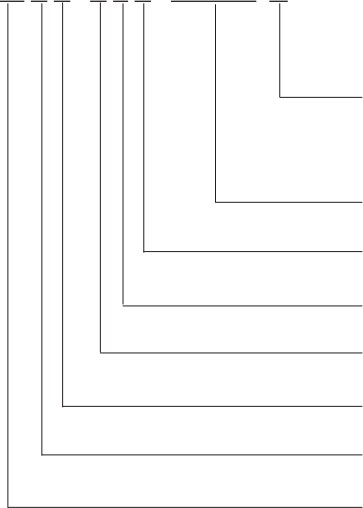

Angle:
0°

Format: Square, length P
P = 6,5 mm

Punch cutting length: l₁
13 mm

Length: l

Diameter: d₂

Type:

light

Version:

Square

Punch:

with ejector pin

Order code character
= (A)

= 0650

Order No

= (1)

Order code character

= (E)

Order No

= (2)

Order No

= (2)

Order No

= (2)

= 27

Material:

HSS

Hardness 62 ± 2 HRC

Execution:

Shaft and punch shape fine ground.
Special dimensions on request.

Ball lock punch, stepped, rectangular, with ejector pin, light duty



2732.

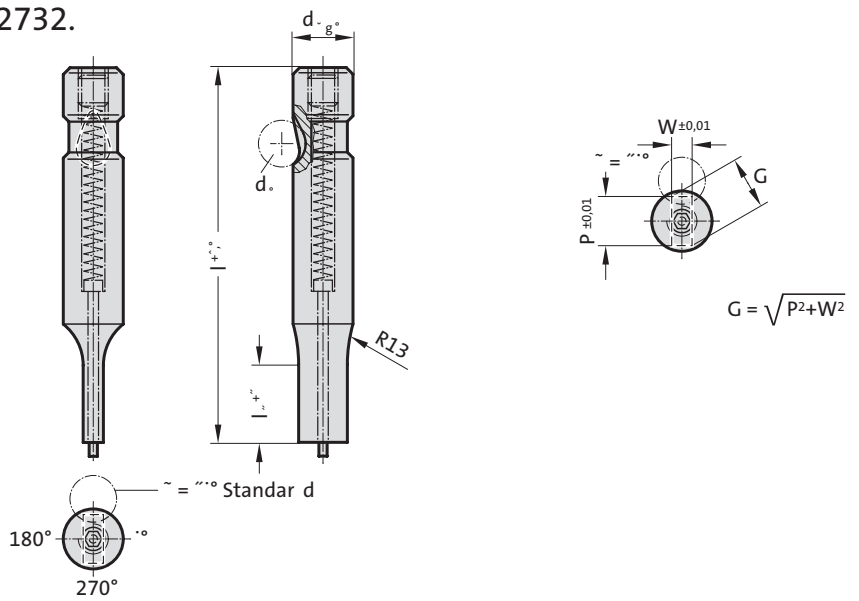

2732. Ball lock punch, stepped, rectangular, with ejector pin, light duty

d_2 / (Order No)	d_s	W_{min}	G_{max}	l_1 / (Order No)*	l / (Order Code character)	63 (C)	71 (D)	80 (E)	90 (F)	100 (G)
6 / (1)	6	1.6	5.9	13 (1)		●	●	●	●	●
10 / (2)	8	1.6	9.9	13 (1) 19 (2)		●	●	●	●	●
13 / (3)	8	4.5	12.9	13 (1) 19 (2)		●	●	●	●	●
16 / (4)	8	6	15.9	13 (1) 19 (2) 25 (3)		●	●	●	●	●
20 / (5)	8	8	19.9	13 (1) 19 (2) 25 (3)		●	●	●	●	●
25 / (6)	8	10	24.9	13 (1) 19 (2) 25 (3)		●	●	●	●	●
32 / (7)	8	12.5	31.9	13 (1) 19 (2) 25 (3)			●	●	●	●
38 / (8)	8	14	37.9	19 (2) 25 (3) 30 (4)				●	●	●

* $l_1=10$ where $W < 2.20$



Material:

HSS
Hardness 62 ± 2 HRC

Execution:

Shaft and punch shape fine ground.
Special dimensions on request.

Ordering-code (example):

2732.2F1.0650.0450B

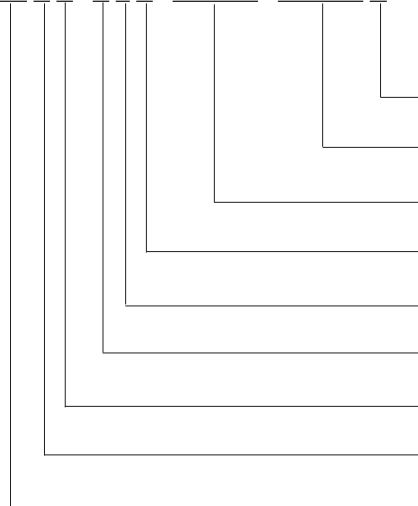

Angle: 90°
Format: Rectangular, width W
 $W = 4,5$ mm
Format: Rectangular, length P
 $P = 6,5$ mm
Punch cutting length: l_1
13 mm
Length: l
90 mm
Diameter: d_2
10 mm
Type: light
Version: Rectangular
Punch: with ejector pin

Order code character = (B)
Order No = 0450
Order No = 0650
Order No = (1)
Order code character = (F)
Order No = (2)
Order No = (2)
Order No = (3)
Order No = 27

Ball lock punch, stepped, slot, with ejector pin, light duty

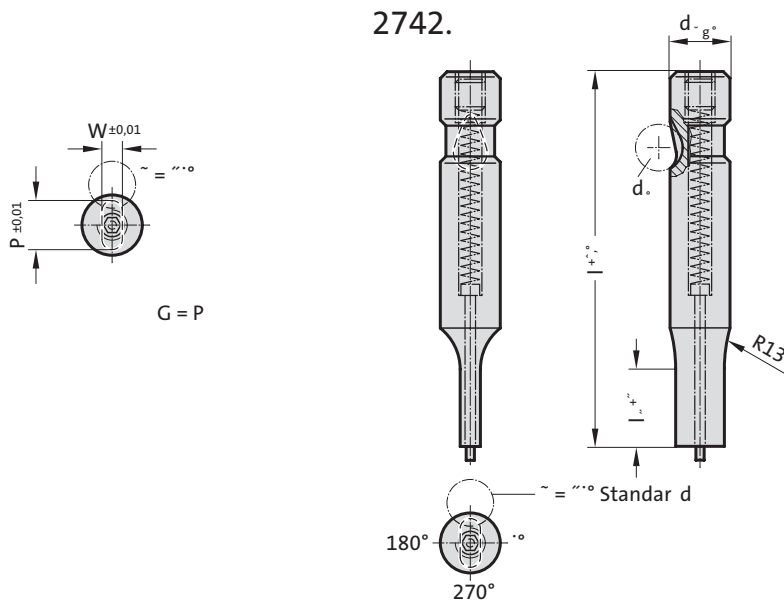

2742. Ball lock punch, stepped, slot, with ejector pin, light duty

d ₂ / (Order No)	d ₅	W _{min}	G _{max}	l ₁ / (Order No)*	l / (Order Code character)	63 (C)	71 (D)	80 (E)	90 (F)	100 (G)
6 / (1)	6	1.6	5.9	13 (1)		●	●	●	●	●
10 / (2)	8	1.6	9.9	13 (1) 19 (2)		●	●	●	●	●
13 / (3)	8	4.5	12.9	13 (1) 19 (2)		●	●	●	●	●
16 / (4)	8	6	15.9	13 (1) 19 (2) 25 (3)		●	●	●	●	●
20 / (5)	8	8	19.9	13 (1) 19 (2) 25 (3)		●	●	●	●	●
25 / (6)	8	10	24.9	13 (1) 19 (2) 25 (3)		●	●	●	●	●
32 / (7)	8	12.5	31.9	13 (1) 19 (2) 25 (3)		●	●	●	●	●
38 / (8)	8	14	37.9	19 (2) 25 (3) 30 (4)		●	●	●	●	●

*l₁=10 where W < 2.20

Ordering-code (example):

2742.2F1.0650.0450B

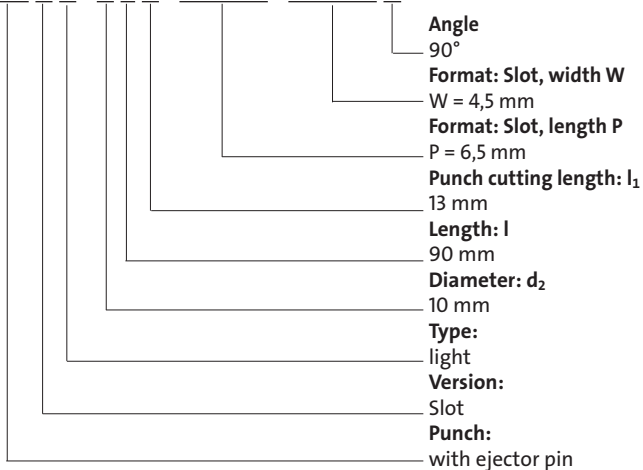

Order code character
 = (B)
 = 0450
 = 0650
Order No
 = (1)
Order code character
 = (F)
Order No
 = (2)
Order No
 = (2)
Order No
 = (4)
 = 27

Material:

HSS
 Hardness 62 ± 2 HRC

Execution:

Shaft and punch shape fine ground.
 Special dimensions on request.

Ball lock punch, stepped, rectangle with radiussed corners, with ejector pin, light duty



2752.

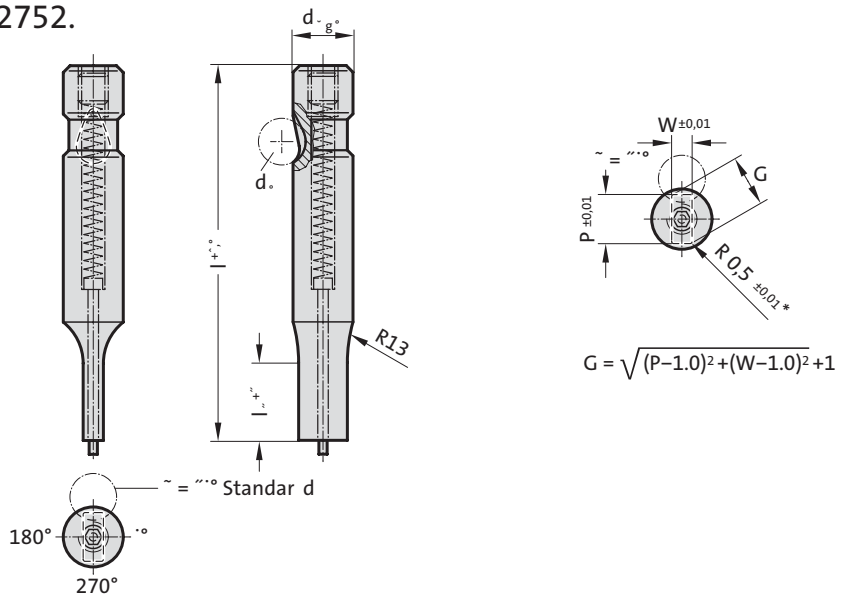

2752. Ball lock punch, stepped, rectangle with radiussed corners, with ejector pin, light duty

d_2 / (Order No)	d_s	W_{\min}	G_{\max}	l_1 / (Order No)*	l / (Order Code character)	63 (C)	71 (D)	80 (E)	90 (F)	100 (G)
6 / (1)	6	1.6	5.9	13 (1)		●	●	●	●	●
10 / (2)	8	1.6	9.9	13 (1) 19 (2)		●	●	●	●	●
13 / (3)	8	4.5	12.9	13 (1) 19 (2)		●	●	●	●	●
16 / (4)	8	6	15.9	13 (1) 19 (2) 25 (3)		●	●	●	●	●
20 / (5)	8	8	19.9	13 (1) 19 (2) 25 (3)		●	●	●	●	●
25 / (6)	8	10	24.9	13 (1) 19 (2) 25 (3)		●	●	●	●	●
32 / (7)	8	12.5	31.9	13 (1) 19 (2) 25 (3)			●	●	●	●
38 / (8)	8	14	37.9	19 (2) 25 (3) 30 (4)				●	●	●

* $l_1=10$ where $W < 2.20$



Material:

HSS
Hardness 62 ± 2 HRC

Execution:

Shaft and punch shape fine ground.
Special dimensions on request.
* For other radius options, see standardised special shapes.

Ordering-code (example):

2752.2F1.0650.0450B

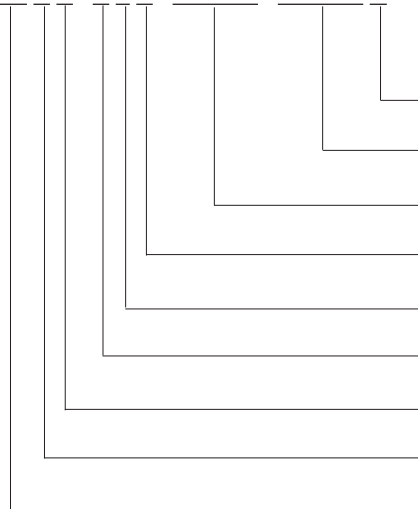

Angle: 90°
Format: Rectangle with radiussed corners, width W
 $W = 4,5$ mm
Format: Rectangle with radiussed corners, length P
 $P = 6,5$ mm
Punch cutting length: l_1
13 mm
Length: l
90 mm
Diameter: d_2
10 mm
Type: light
Version: Rectangle with radiussed corners
Punch: with ejector pin

Order code character = (B)
= 0450
= 0650
Order No = (1)
Order code character = (F)
Order No = (2)
Order No = (2)
Order No = (5)
= 27

Ball lock punch, punch larger than shaft, blank, light duty

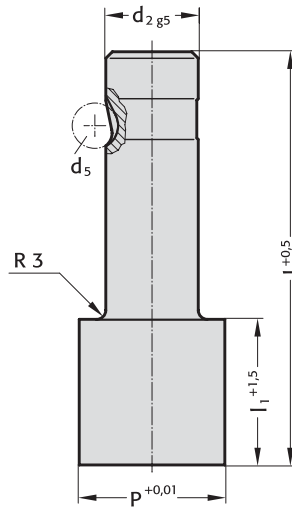
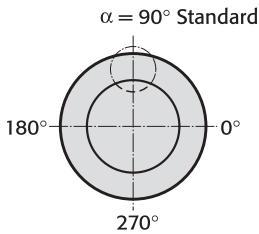

2204. Ball lock punch, punch larger than shaft, blank, light duty

d ₂ / (Order No)	d ₅	P	l ₁ / (Order No)	l / (Order Code character)	80 (E)	90 (F)	100 (G)
13 / (3)	8	32	19 (2) 30 (4)		●	●	●
16 / (4)	8	38	19 (2) 30 (4)		●	●	●
20 / (5)	8	40	19 (2) 30 (4)		●	●	●
25 / (6)	8	44	19 (2) 30 (4)		●	●	●
32 / (7)	8	50	19 (2) 30 (4)		●	●	●

Ordering-code (example):

2 2 0 4 . 4 F 4 . 3 8 0 0

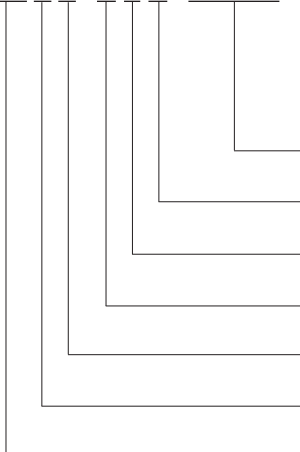

Format: Round
 P = ø38,0 mm
Punch cutting length: l₁
 30 mm
length: l
 90 mm
diameter: d₂
 16 mm
Type:
 punch larger, light duty
Version:
 Blank
Punch:
 without ejector pin

= 3800
Order No
 = (4)
Order code character
 = (F)
Order No
 = (4)
Order No
 = (4)
Order No
 = (0)
 = 22

Material:

HSS
 Hardness 62 ± 2 HRC

Execution:

Shaft and punch diameter fine ground.
 Special dimensions on request.

Ball lock punch, punch larger than shaft, round, light duty

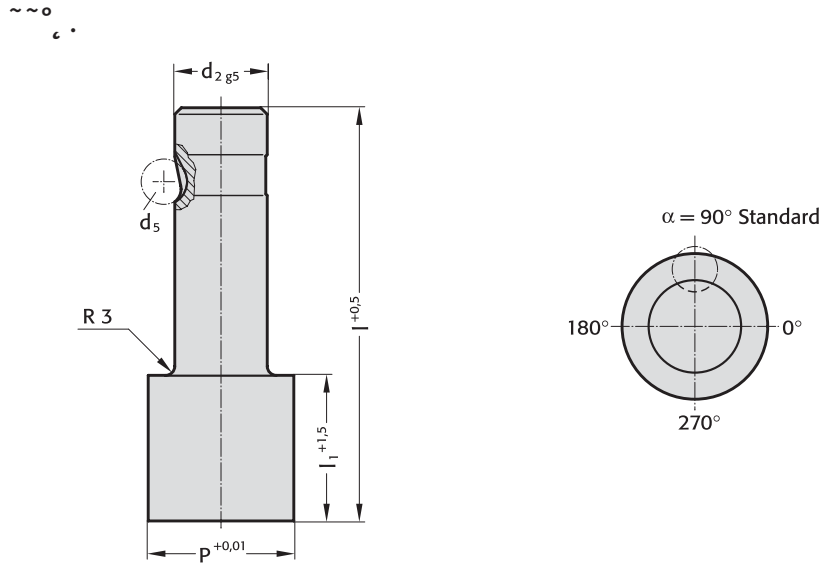

2214. Ball lock punch, punch larger than shaft, round, light duty

d ₂ / (Order No)	d ₅	P	l ₁ / (Order No)	l / (Order Code character)	80 (E)	90 (F)	100 (G)
13 / (3)	8	13 - 32	19 (2) 30 (4)		●	●	●
16 / (4)	8	16 - 38	19 (2) 30 (4)		●	●	●
20 / (5)	8	20 - 40	19 (2) 30 (4)		●	●	●
25 / (6)	8	25 - 44	19 (2) 30 (4)		●	●	●
32 / (7)	8	32 - 50	19 (2) 30 (4)		●	●	●

Material:

HSS
Hardness 62 ± 2 HRC

Execution:

Shaft and punch diameter fine ground.
Special dimensions on request.

Ordering-code (example):

2 2 1 4 . 7 G 2 . 3 8 0 0

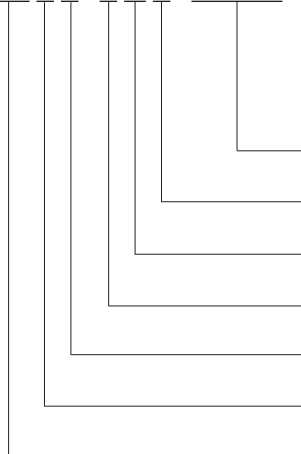

Format: Round
P = Ø 38,0 mm
Punch cutting length: l₁
 19 mm
length: l
 100 mm
diameter: d₂
 32 mm
Type:
 punch larger, light duty
Version:
 Round
Punch:
 without ejector pin

= 3800
Order No
 = (2)
Order code character
 = (G)
Order No
 = (7)
Order No
 = (4)
Order No
 = (1)
 = 22

Ball lock punch, punch larger than shaft, square, light duty

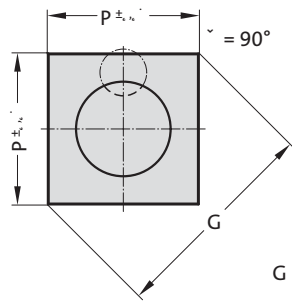

$$G = \sqrt{2} \times P$$

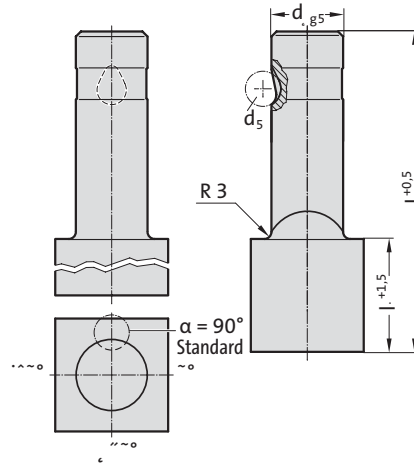

2224. Ball lock punch, punch larger than shaft, square, light duty

d_2 / (Order No)	d_5	P_{min}	G_{max}	l_1 / (Order No)	l / (Order Code character)	80 (E)	90 (F)	100 (G)
13 / (3)	8	9.19	32	19 (2) 30 (4)		●	●	●
16 / (4)	8	11.31	38	19 (2) 30 (4)		●	●	●
20 / (5)	8	14.14	40	19 (2) 30 (4)		●	●	●
25 / (6)	8	17.68	44	19 (2) 30 (4)		●	●	●
32 / (7)	8	22.63	50	19 (2) 30 (4)		●	●	●

Ordering-code (example):

22 24 . 7 F 2 . 35 35 A

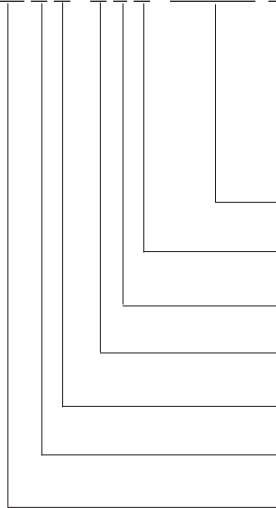

Angle:
0°

Format: Square, length P

P = 35,35 mm

Punch cutting length: l_1

19 mm

Length: l

90 mm

Diameter: d_2

32 mm

Type:

punch larger, light duty

Version:

Square

Punch:

without ejector pin

Order code character
= (A)

= 3535

Order No

= (2)

Order code character

= (F)

Order No

= (7)

Order No

= (4)

Order No

= (2)

= 22

Material:

HSS

Hardness 62 ± 2 HRC

Execution:

Shaft and punch shape fine ground.
Special dimensions on request.

Ball lock punch, punch larger than shaft, rectangular, light duty



2234.

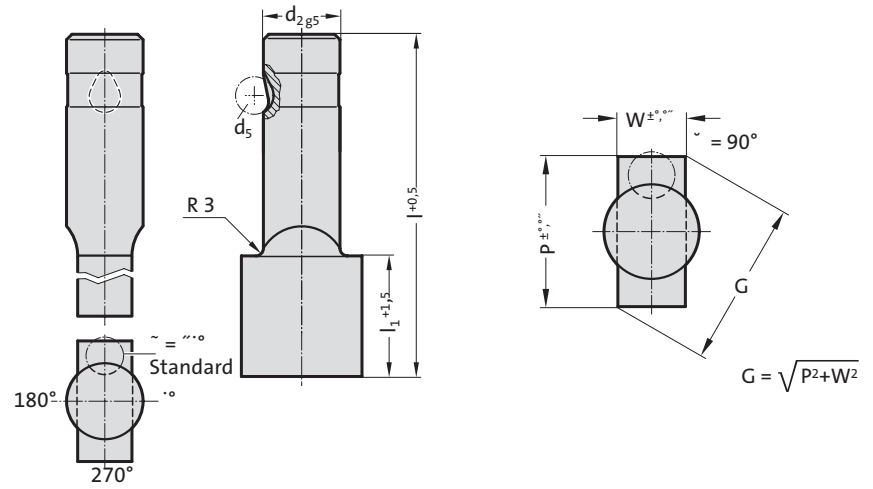

2234. Ball lock punch, punch larger than shaft, rectangular, light duty

d ₂ / (Order No)	d ₅	W _{min}	G _{max}	l ₁ / (Order No)	l / (Order Code character)	80 (E)	90 (F)	100 (G)
13 / (3)	8	5	32	19 (2) 30 (4)		●	●	●
16 / (4)	8	6.5	38	19 (2) 30 (4)		●	●	●
20 / (5)	8	8	40	19 (2) 30 (4)		●	●	●
25 / (6)	8	10	44	19 (2) 30 (4)		●	●	●
32 / (7)	8	11.5	50	19 (2) 30 (4)		●	●	●



Material:

HSS
Hardness 62 ± 2 HRC

Execution:

Shaft and punch shape fine ground.
Special dimensions on request.

Ordering-code (example):

2 2 3 4 . 7 F 2 . 3 8 0 0 . 1 1 5 0 B

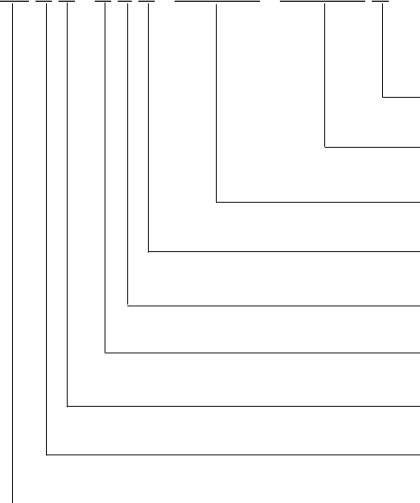

Angle: 90°
Format: Rectangular, width W W = 11,5 mm
Format: Rectangular, length P P = 38 mm
Punch cutting length: l₁ 19 mm
Length: l 90 mm
Diameter: d₂ 32 mm
Type: punch larger, light duty
Version: Rectangular
Punch: without ejector pin

Order code character = (B)
Order No = 1150
Order No = 3800
Order code character = (F)
Order No = (7)
Order No = (4)
Order No = (3)
Order No = 22

Ball lock punch, punch larger than shaft, slot, light duty



2244.

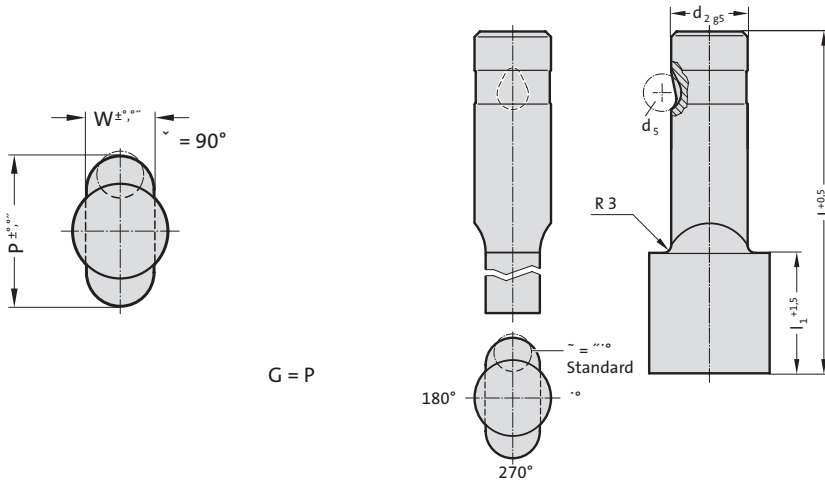

2244. Ball lock punch, punch larger than shaft, slot, light duty

d ₂ / (Order No)	d ₅	W _{min}	G _{max}	l ₁ / (Order No)	l / (Order Code character)	80 (E)	90 (F)	100 (G)
13 / (3)	8	5	32	19 (2) 30 (4)		●	●	●
16 / (4)	8	6.5	38	19 (2) 30 (4)		●	●	●
20 / (5)	8	8	40	19 (2) 30 (4)		●	●	●
25 / (6)	8	10	44	19 (2) 30 (4)		●	●	●
32 / (7)	8	11.5	50	19 (2) 30 (4)		●	●	●

Ordering-code (example):

2244.4F2.3800.0650B

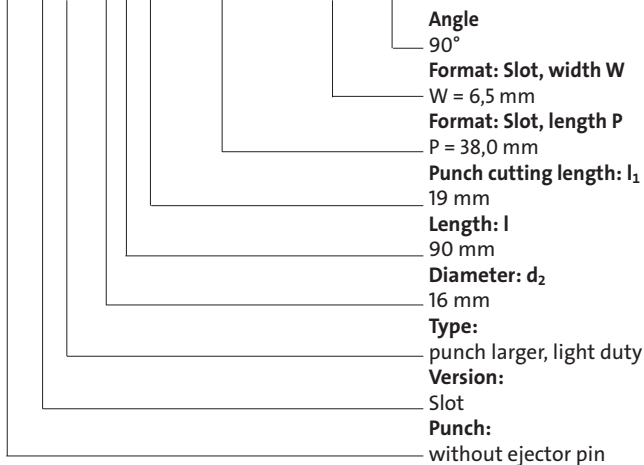

Order code character = (B)
= 0650
= 3800
Order No = (2)
Order code character = (F)
Order No = (4)
Order No = (4)
Order No = (4)
= 22

Material:

HSS
Hardness 62 ± 2 HRC

Execution:

Shaft and punch shape fine ground.
Special dimensions on request.

Ball lock punch, punch larger than shaft, rectangle with radiussed corners, light duty



2254.

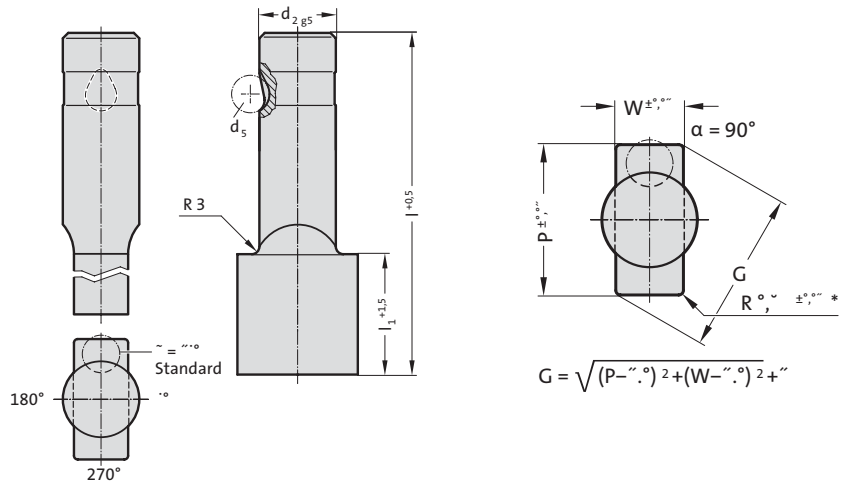

2254. Ball lock punch, punch larger than shaft, rectangle with radiussed corners, light duty

d ₂ / (Order No)	d ₅	W _{min}	G _{max}	l ₁ / (Order No)	l / (Order Code character)	80 (E)	90 (F)	100 (G)
13 / (3)	8	5	32	19 (2) 30 (4)		●	●	●
16 / (4)	8	6.5	38	19 (2) 30 (4)		●	●	●
20 / (5)	8	8	40	19 (2) 30 (4)		●	●	●
25 / (6)	8	10	44	19 (2) 30 (4)		●	●	●
32 / (7)	8	11.5	50	19 (2) 30 (4)		●	●	●



Material:

HSS
Hardness 62 ± 2 HRC

Execution:

Shaft and punch shape fine ground.
Special dimensions on request.
* For other radius options, see standardised special shapes.

Ordering-code (example):

2254.7F2.3800.1150B

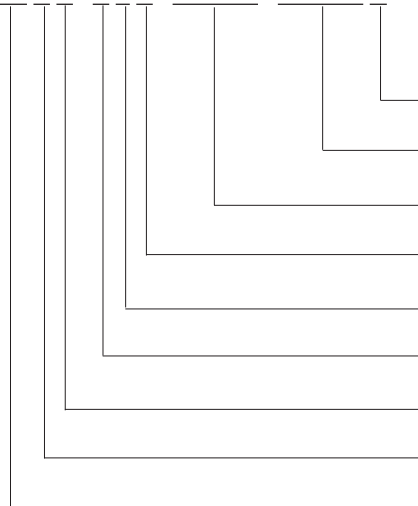

Angle: 90°
Format: Rectangle with radiussed corners, width W = 11,5 mm
Format: Rectangle with radiussed corners, length P = 38,0 mm
Punch cutting length: l₁ = 19 mm
Length: l = 90 mm
Diameter: d₂ = 32 mm
Type: punch larger, light duty
Version: Rectangle with radiussed corners
Punch: without ejector pin

Order code character = (B)
Order No = 1150
Order No = 3800
Order No = (2)
Order code character = (F)
Order No = (7)
Order No = (4)
Order No = (5)
Order No = 22

Ball lock punch, punch larger than shaft, blank, with ejector pin, light duty

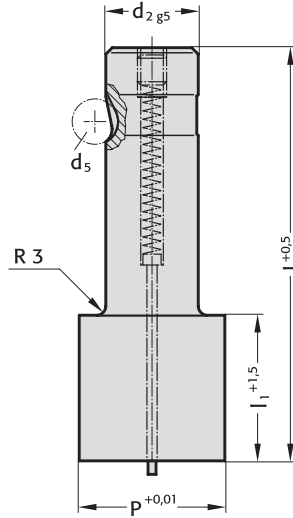
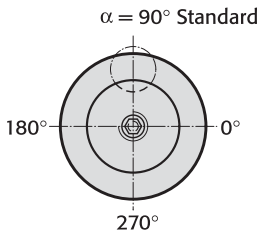

2704. Ball lock punch, punch larger than shaft, blank, with ejector pin, light duty

d ₂ / (Order No)	d ₅	P	l ₁ / (Order No)	l / (Order Code character)	80 (E)	90 (F)	100 (G)
13 / (3)	8	32	19 (2) 30 (4)		●	●	●
16 / (4)	8	38	19 (2) 30 (4)		●	●	●
20 / (5)	8	40	19 (2) 30 (4)		●	●	●
25 / (6)	8	44	19 (2) 30 (4)		●	●	●
32 / (7)	8	50	19 (2) 30 (4)		●	●	●



Ordering-code (example):

2704.4F4.3800

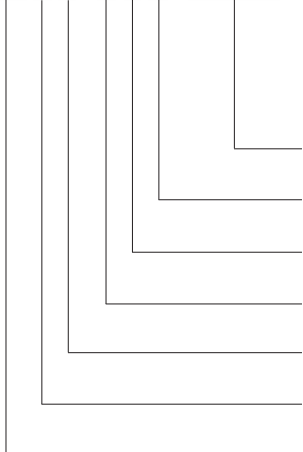

Format: Round
P = ø38,0 mm
Punch cutting length: l₁
30 mm
length: l
90 mm
diameter: d₂
16 mm
Type:
punch larger, light duty
Version:
Blank
Punch:
with ejector pin

= 3800
Order No
= (4)
Order code character
= (F)
Order No
= (4)
Order No
= (4)
Order No
= (0)
= 27

Material:

HSS
Hardness 62 ± 2 HRC

Execution:

Shaft and punch diameter fine ground.
Special dimensions on request.

Ball lock punch, punch larger than shaft, round, with ejector pin, light duty



~ 0 °

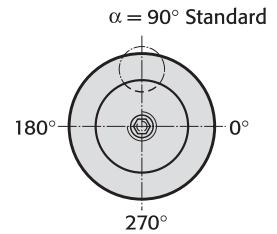
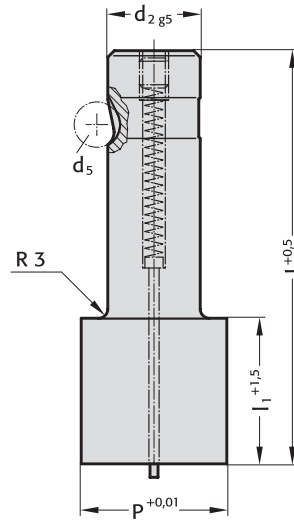

2714. Ball lock punch, punch larger than shaft, round, with ejector pin, light duty

d ₂ / (Order No)	d ₅	P	l ₁ / (Order No)	l / (Order Code character)	80 (E)	90 (F)	100 (G)
13 / (3)	8	13 - 32	19 (2) 30 (4)		●	●	●
16 / (4)	8	16 - 38	19 (2) 30 (4)		●	●	●
20 / (5)	8	20 - 40	19 (2) 30 (4)		●	●	●
25 / (6)	8	25 - 44	19 (2) 30 (4)		●	●	●
32 / (7)	8	32 - 50	19 (2) 30 (4)		●	●	●



Material:

HSS
Hardness 62 ± 2 HRC

Execution:

Shaft and punch diameter fine ground.
Special dimensions on request.

Ordering-code (example):

2 7 1 4 . 7 G 2 . 4 2 5 0

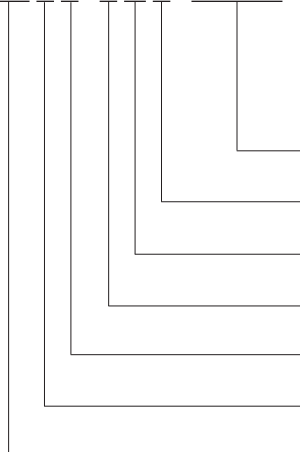

Format: Round
P = Ø 42,5 mm
Punch cutting length: l₁
 19 mm
length: l
 100 mm
diameter: d₂
 32 mm
Type:
 punch larger, light duty
Version:
 Round
Punch:
 with ejector pin

= 4250
Order No
 = (2)
Order code character
 = (G)
Order No
 = (7)
Order No
 = (4)
Order No
 = (1)
 = 27

Ball lock punch, punch larger than shaft, square, with ejector pin, light duty

2724.

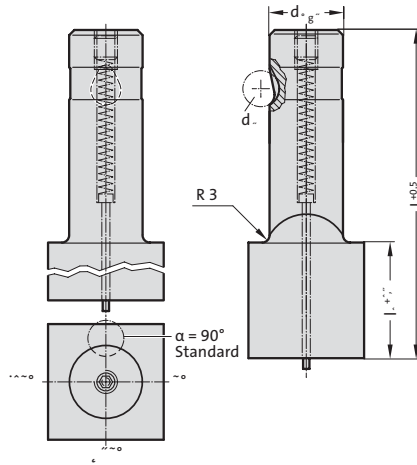
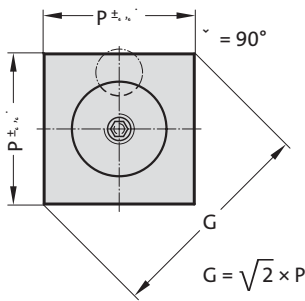

2724. Ball lock punch, punch larger than shaft, square, with ejector pin, light duty

d ₂ / (Order No)	d ₅	P _{min}	G _{max}	l ₁ / (Order No)	l / (Order Code character)	80 (E)	90 (F)	100 (G)
13 / (3)	8	9.19	32	19 (2) 30 (4)		●	●	●
16 / (4)	8	11.31	38	19 (2) 30 (4)		●	●	●
20 / (5)	8	14.14	40	19 (2) 30 (4)		●	●	●
25 / (6)	8	17.68	44	19 (2) 30 (4)		●	●	●
32 / (7)	8	22.63	50	19 (2) 30 (4)		●	●	●



Ordering-code (example):

27 24 . 5 E 2 . 2 8 2 8 A

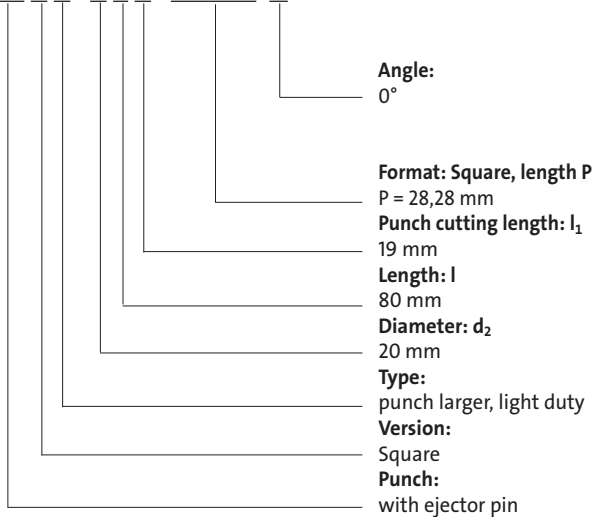

Order code character = (A)

= 2828

Order No = (2)

Order code character = (E)

Order No = (5)

Order No = (4)

Order No = (2)

= 27

Material:

HSS
Hardness 62 ± 2 HRC

Execution:

Shaft and punch shape fine ground.
Special dimensions on request.

Ball lock punch, punch larger than shaft, rectangular, with ejector pin, light duty

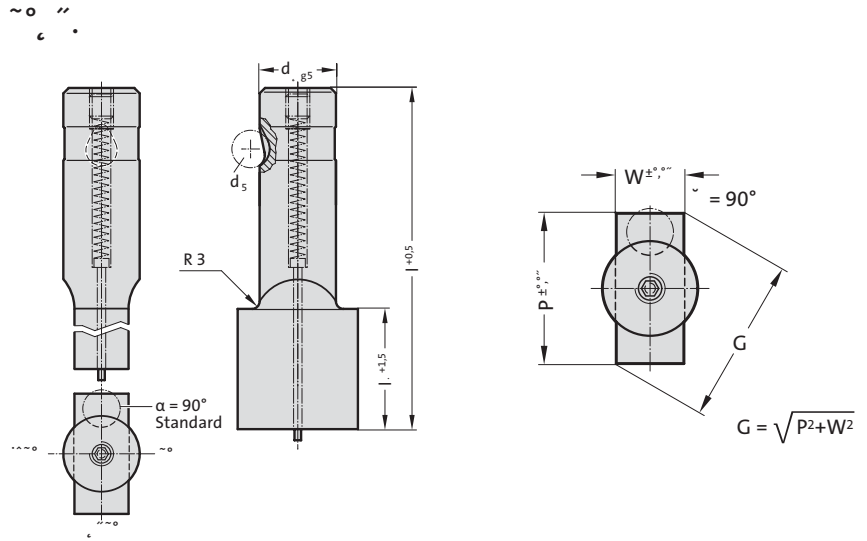

2734. Ball lock punch, punch larger than shaft, rectangular, with ejector pin, light duty

d ₂ / (Order No)	d ₅	W _{min}	G _{max}	l ₁ / (Order No)	l / (Order Code character)	80 (E)	90 (F)	100 (G)
13 / (3)	8	5	32	19 (2) 30 (4)		●	●	●
16 / (4)	8	6.5	38	19 (2) 30 (4)		●	●	●
20 / (5)	8	8	40	19 (2) 30 (4)		●	●	●
25 / (6)	8	10	44	19 (2) 30 (4)		●	●	●
32 / (7)	8	11.5	50	19 (2) 30 (4)		●	●	●



Material:

HSS
Hardness 62 ± 2 HRC

Execution:

Shaft and punch shape fine ground.
Special dimensions on request.

Ordering-code (example):

2734.7F2.3800.1150B

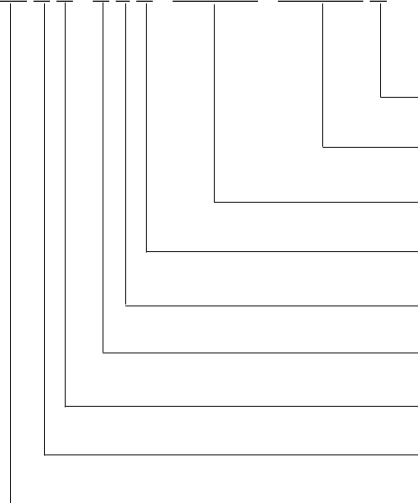

- Angle:** 90° **Order code character** = (B)
- Format: Rectangular, width W** W = 11,5 mm = 1150
- Format: Rectangular, length P** P = 38 mm = 3800
- Punch cutting length: l₁** 19 mm **Order No** = (2)
- Length: l** 90 mm **Order code character** = (F)
- Diameter: d₂** 32 mm **Order No** = (7)
- Type:** punch larger, light duty **Order No** = (4)
- Version:** Rectangular **Order No** = (3)
- Punch:** with ejector pin = 27

Ball lock punch, punch larger than shaft, slot, with ejector pin, light duty

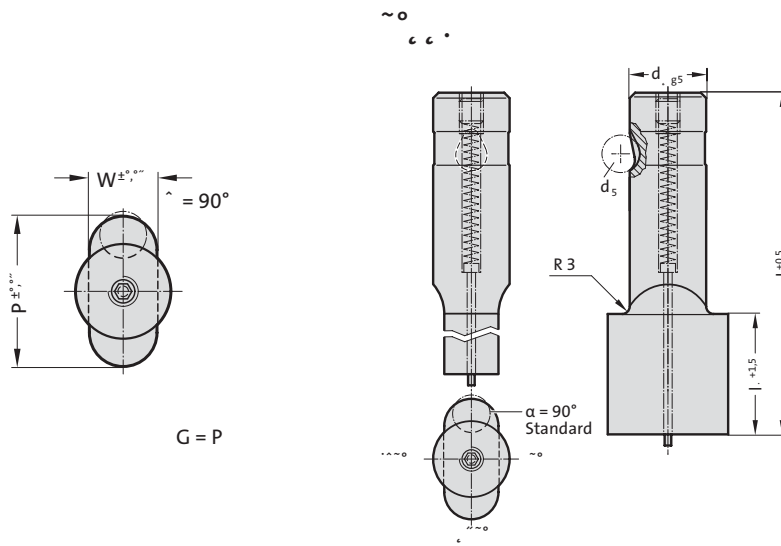

2744. Ball lock punch, punch larger than shaft, slot, with ejector pin, light duty

d ₂ / (Order No)	d ₅	W _{min}	G _{max}	l ₁ / (Order No)	l / (Order Code character)	80 (E)	90 (F)	100 (G)
13 / (3)	8	5	32	19 (2) 30 (4)		●	●	●
16 / (4)	8	6.5	38	19 (2) 30 (4)		●	●	●
20 / (5)	8	8	40	19 (2) 30 (4)		●	●	●
25 / (6)	8	10	44	19 (2) 30 (4)		●	●	●
32 / (7)	8	11.5	50	19 (2) 30 (4)		●	●	●



Ordering-code (example):

2744.7F2.3800.1150B

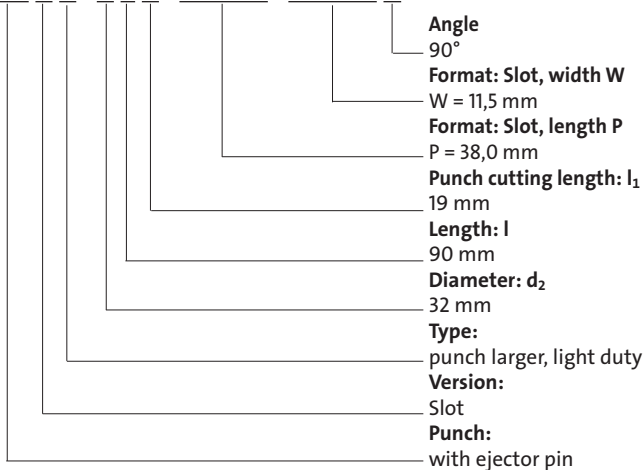

Order code character = (B)
= 1150
= 3800
Order No = (2)
Order code character = (F)
Order No = (7)
Order No = (4)
Order No = (4)
= 27

Material:

HSS
Hardness 62 ± 2 HRC

Execution:

Shaft and punch shape fine ground.
Special dimensions on request.

Ball lock punch, punch larger than shaft, rectangle with radiussed corners, with ejector pin, light duty

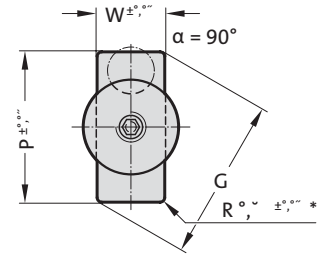
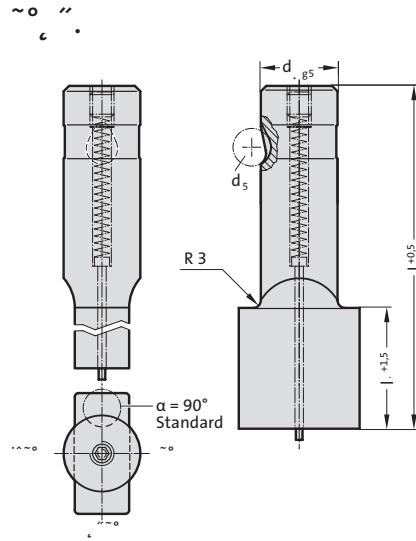

$$G = \sqrt{(P - \dots)^2 + (W - \dots)^2} + \dots$$

2754. Ball lock punch, punch larger than shaft, rectangle with radiussed corners, with ejector pin, light duty

d ₂ / (Order No)	d ₅	W _{min}	G _{max}	l ₁ / (Order No)	l / (Order Code character)	80 (E)	90 (F)	100 (G)
13 / (3)	8	5	32	19 (2) 30 (4)		●	●	●
16 / (4)	8	6.5	38	19 (2) 30 (4)		●	●	●
20 / (5)	8	8	40	19 (2) 30 (4)		●	●	●
25 / (6)	8	10	44	19 (2) 30 (4)		●	●	●
32 / (7)	8	11.5	50	19 (2) 30 (4)		●	●	●



Material:

HSS
Hardness 62 ± 2 HRC

Execution:

Shaft and punch shape fine ground.
Special dimensions on request.
* For other radius options, see standardised special shapes.

Ordering-code (example):

2754.7F2.3800.1150B

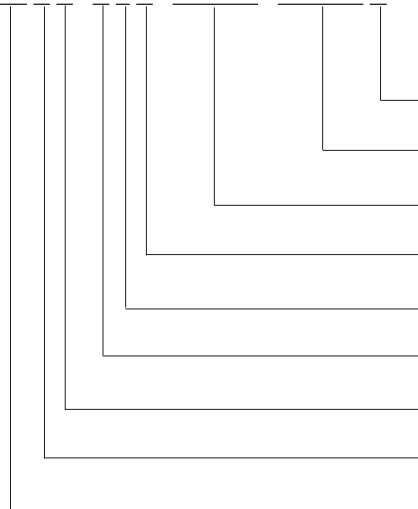

Angle: 90°
Format: Rectangle with radiussed corners, width W = 11,5 mm
Format: Rectangle with radiussed corners, length P = 38,0 mm
Punch cutting length: l₁ = 19 mm
Length: l = 90 mm
Diameter: d₂ = 32 mm
Type: punch larger, light duty
Version: Rectangle with radiussed corners
Punch: with ejector pin

Order code character = (B)
Order No = 1150
Order No = 3800
Order No = (2)
Order code character = (F)
Order No = (7)
Order No = (4)
Order No = (5)
Order No = 27



Ball lock pilot pin, with tapered tip, light duty

2262.

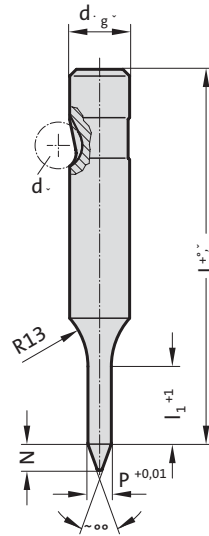

2262. Ball lock pilot pin, with tapered tip, light duty

d ₂ / (Order No)	d ₅	P	l ₁ / (Order No)	N	l / (Order Code character)	71 (D)	80 (E)	90 (F)	100 (G)	110 (H)	125 (J)	140 (K)	150 (I)
10 / (2)	8	5.9 - 9.9	19 (2)	8		●	●	●	●	●			
13 / (3)	8	9.9 - 12.9	19 (2)	10		●	●	●	●	●	●		
16 / (4)	8	12.9 - 15.9	25 (3)	15		●	●	●	●	●	●		●
20 / (5)	8	15.9 - 19.9	25 (3)	20		●	●	●	●	●	●	●	●
25 / (6)	8	19.9 - 24.9	25 (3)	25		●	●	●	●	●	●	●	●
32 / (7)	8	24.9 - 31.9	25 (3)	30			●	●	●	●	●	●	●
38 / (8)	8	31.9 - 37.9	30 (4)	35			●	●	●	●	●	●	●

Ordering-code (example):

2262.4G3.1400

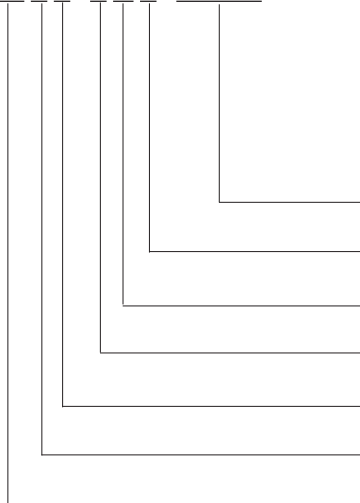

- Format: Round**
- P = Ø 14,0 mm** = 1400
- Punch cutting length: l₁** = 25 mm
- Length: l** = 100 mm
- Diameter: d₂** = 16 mm
- Type:** light
- Version:** Pilot pin with tapered tip
- Punch:** without ejector pin = 22
- Order No** = (3)
- Order code character** = (G)
- Order No** = (4)
- Order No** = (2)
- Order No** = (6)

Material:

HSS
Hardness 62 ± 2 HRC

Execution:

Shaft and pilot pin fine ground.
Special dimensions on request.

Ball lock pilot pin, with parabolic tip, light duty



2272.

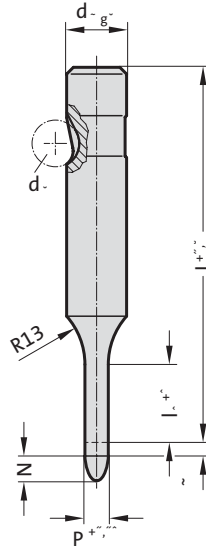

2272. Ball lock pilot pin, with parabolic tip, light duty

d ₂ / (Order No)	d ₅	P	l ₁ / (Order No)	l / (Order Code character)	50 (A)	56 (B)	63 (C)	71 (D)	80 (E)	90 (F)	100 (G)
6 / (1)	6	2,9-5,9	13 (1)		●	●	●	●	●	●	●
10 / (2)	8	5,9-9,9	19 (2)		●	●	●	●	●	●	●
13 / (3)	8	9,9-12,9	19 (2)		●	●	●	●	●	●	●
16 / (4)	8	12,9-15,9	25 (3)				●	●	●	●	●
20 / (5)	8	15,9-19,9	25 (3)				●	●	●	●	●
25 / (6)	8	19,9-24,9	25 (3)				●	●	●	●	●
32 / (7)	8	24,9-31,9	25 (3)					●	●	●	●
38 / (8)	8	31,9-37,9	30 (4)						●	●	●

Material:

HSS
Hardness 62 ± 2 HRC

Execution:

Shaft and pilot pin fine ground.
Special dimensions on request.

Note:

The 2 mm length provides full guidance before the blanking punch contacts the sheet metal.

Length of parabolic tip N:

= 8 mm where P ≤ 10 mm
= 12 mm where P 10,1 mm - 15 mm
= 15 mm where P > 15 mm

Ordering-code (example):

2 2 7 2 . 4 G 3 . 1 4 0 0

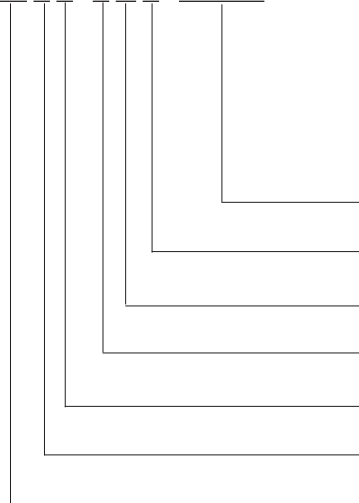

Format: Round

P = Ø 14,0 mm

Punch cutting length: l₁
25 mm

Length: l

100 mm

Diameter: d₂

16 mm

Type:

light

Version:

Pilot pin with parabolic tip

Punch:

without ejector pin

= 1400

Order No

= (3)

Order code character

= (G)

Order No

= (4)

Order No

= (2)

Order No

= (7)

= 22

Ball lock punch, blank, heavy duty

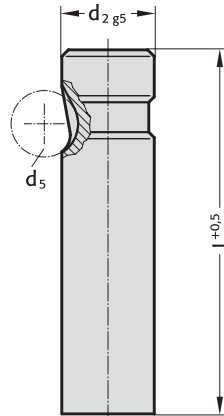

2203. Ball lock punch, blank, heavy duty

d ₂ / (Order No)	d ₅	l / (Order Code character)	63 (C)	71 (D)	80 (E)	90 (F)	100 (G)	110 (H)	125 (J)	140 (K)	150 (L)	175 (M)	200 (N)
10 / (2)	10		●	●	●	●	●	●	●	●	●	●	●
13 / (3)	12		●	●	●	●	●	●	●	●	●	●	●
16 / (4)	12		●	●	●	●	●	●	●	●	●	●	●
20 / (5)	12		●	●	●	●	●	●	●	●	●	●	●
25 / (6)	12			●	●	●	●	●	●	●	●	●	●
32 / (7)	12			●	●	●	●	●	●	●	●	●	●
40 / (9)	12				●	●	●	●	●	●	●	●	●

Ordering code (example):

2203.7G

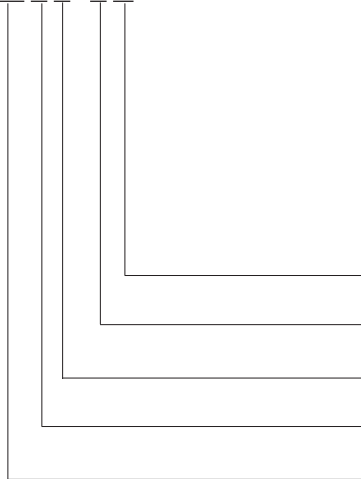

Length: l
100 mm
Diameter: d₂
32 mm
Type:
heavy duty
Version:
blank
Punch:
without ejector pin

Order Code character
= (G)
Order No
= (7)
Order No
= (3)
Order No
= (0)
= 22

Material:

HSS
Hardness 62 ± 2 HRC

Execution:

Shaft fine ground.
Special dimensions on request.

Ball lock punch, stepped, round, heavy duty

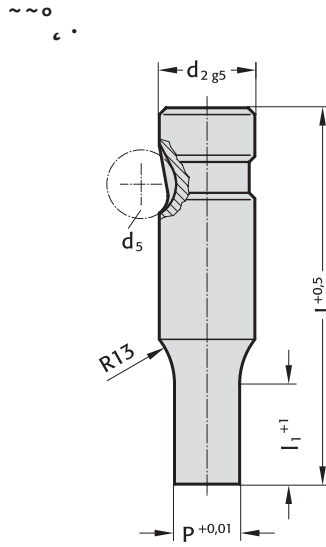

2213. Ball lock punch, stepped, round, heavy duty

d ₂ / (Order No)	d ₅	P	l ₁ / (Order No)*	l / (Order Code character)	63 (C)	71 (D)	80 (E)	90 (F)	100 (G)	110 (H)	125 (J)
10 / (2)	10	1.6 - 9.9	13 (1) 19 (2)		●	●	●	●	●	●	●
13 / (3)	12	5 - 12.9	13 (1) 19 (2)		●	●	●	●	●	●	●
16 / (4)	12	8 - 15.9	13 (1) 19 (2) 25 (3)		●	●	●	●	●	●	●
20 / (5)	12	12 - 19.9	13 (1) 19 (2) 25 (3)		●	●	●	●	●	●	●
25 / (6)	12	16 - 24.9	13 (1) 19 (2) 25 (3)			●	●	●	●	●	●
32 / (7)	12	24 - 31.9	13 (1) 19 (2) 25 (3)			●	●	●	●	●	●
40 / (9)	12	30 - 39.9	19 (2) 25 (3) 30 (4)				●	●	●	●	●

*l₁=10 where P < 2.20

Material:

HSS
Hardness 62 ± 2 HRC

Execution:

Shaft and punch diameter fine ground.
Special dimensions on request.

Ordering-code (example):

2 2 1 3 . 7 G 2 . 2 4 5 0

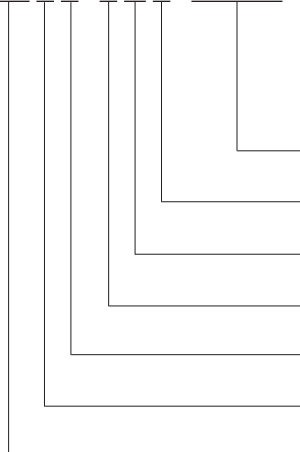

Format: Round
P = ø24,5 mm
Punch cutting length: l₁
19 mm
length: l
100 mm
diameter: d₂
32 mm
Type:
heavy duty
Version:
Round
Punch:
without ejector pin

= 2450
Order No
= (2)
Order code character
= (G)
Order No
= (7)
Order No
= (3)
Order No
= (1)
= 22



Ball lock punch, stepped, square, heavy duty

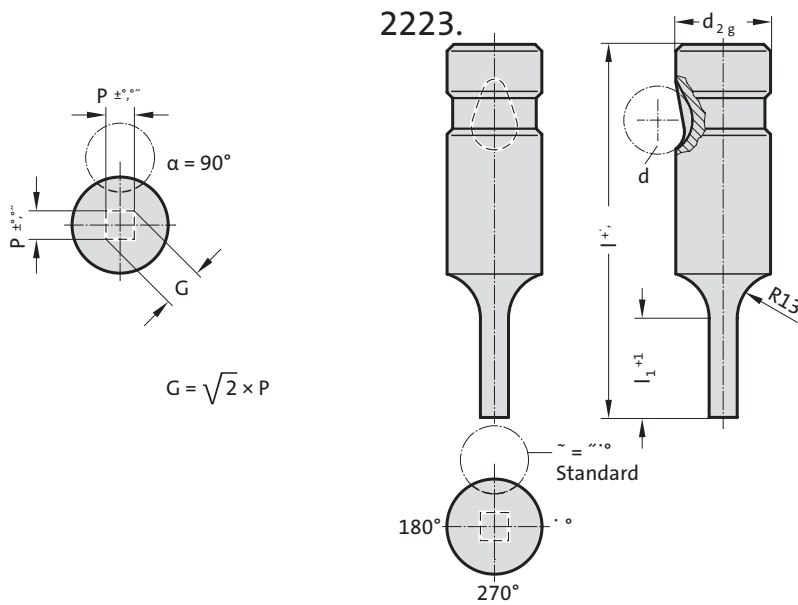

2223. Ball lock punch, stepped, square, heavy duty

d ₂ / (Order No)	d ₅	P _{min}	G _{max}	l ₁ / (Order No)*	l / (Order Code character)	63 (C)	71 (D)	80 (E)	90 (F)	100 (G)	110 (H)	125 (J)
10 / (2)	10	1.6	9.9	13 (1) 19 (2)		●	●	●	●	●	●	●
13 / (3)	12	4.5	12.9	13 (1) 19 (2)		●	●	●	●	●	●	●
16 / (4)	12	6	15.9	13 (1) 19 (2) 25 (3)		●	●	●	●	●	●	●
20 / (5)	12	8	19.9	13 (1) 19 (2) 25 (3)		●	●	●	●	●	●	●
25 / (6)	12	10	24.9	13 (1) 19 (2) 25 (3)			●	●	●	●	●	●
32 / (7)	12	12.5	31.9	13 (1) 19 (2) 25 (3)			●	●	●	●	●	●
40 / (9)	12	14	39.9	19 (2) 25 (3) 30 (4)				●	●	●	●	●

*l₁=10 where P < 2.20

Ordering-code (example):

2223.3F1.0600 B

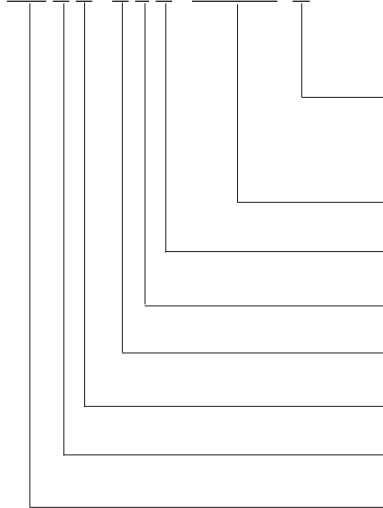

Angle:
90°

Format: Square, length P

P = 6,0 mm

Punch cutting length: l₁

13 mm

Length: l

90 mm

Diameter: d₂

13 mm

Type:

heavy duty

Version:

Square

Punch:

without ejector pin

Order code character
= (B)

= 0600

Order No

= (1)

Order code character

= (F)

Order No

= (3)

Order No

= (3)

Order No

= (2)

= 22

Material:

HSS

Hardness 62 ± 2 HRC

Execution:

Shaft and punch shape fine ground.
Special dimensions on request.

Ball lock punch, stepped, rectangular, heavy duty



2233.

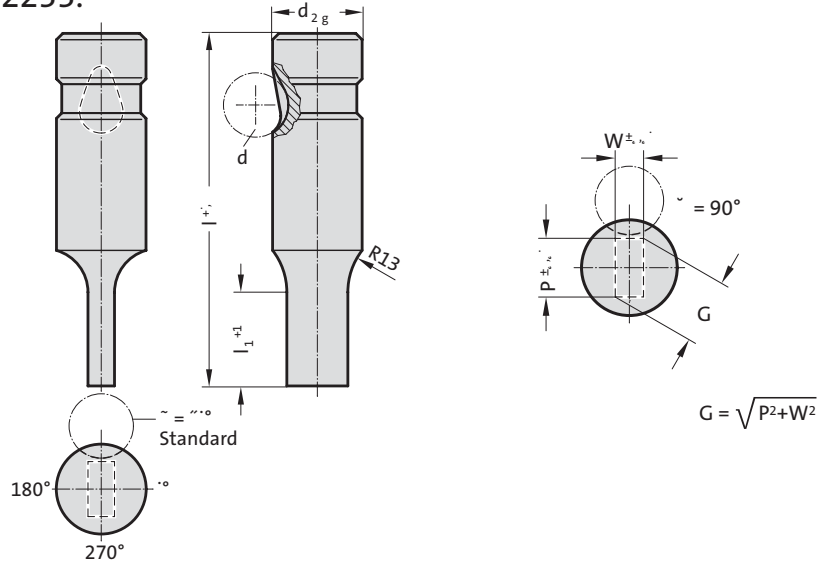

2233. Ball lock punch, stepped, rectangular, heavy duty

d ₂ / (Order No)	d ₅	W _{min}	G _{max}	l ₁ / (Order No)*	l / (Order Code character)	63 (C)	71 (D)	80 (E)	90 (F)	100 (G)	110 (H)	125 (J)
10 / (2)	10	1.6	9.9	13 (1) 19 (2)		●	●	●	●	●	●	●
13 / (3)	12	4.5	12.9	13 (1) 19 (2)		●	●	●	●	●	●	●
16 / (4)	12	6	15.9	13 (1) 19 (2) 25 (3)		●	●	●	●	●	●	●
20 / (5)	12	8	19.9	13 (1) 19 (2) 25 (3)		●	●	●	●	●	●	●
25 / (6)	12	10	24.9	13 (1) 19 (2) 25 (3)			●	●	●	●	●	●
32 / (7)	12	12.5	31.9	13 (1) 19 (2) 25 (3)			●	●	●	●	●	●
40 / (9)	12	14	39.9	19 (2) 25 (3) 30 (4)				●	●	●	●	●

*l₁=10 where W < 2.20

Material:

HSS
Hardness 62 ± 2 HRC

Execution:

Shaft and punch shape fine ground.
Special dimensions on request.

Ordering-code (example):

2 2 3 3 . 2 F 1 . 0 6 5 0 . 0 4 5 0 B

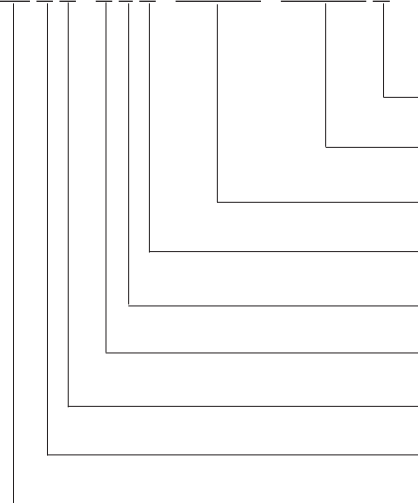

- Angle:** 90° **Order code character** = (B)
- Format: Rectangular, width W** W = 4,5 mm **Order code character** = 0450
- Format: Rectangular, length P** P = 6,5 mm **Order code character** = 0650
- Punch cutting length: l₁** 13 mm **Order No** = (1)
- Length: l** 90 mm **Order code character** = (F)
- Diameter: d₂** 10 mm **Order No** = (2)
- Type:** heavy duty **Order No** = (3)
- Version:** Rectangular **Order No** = (3)
- Punch:** without ejector pin **Order No** = 22



Ball lock punch, stepped, slot, heavy duty

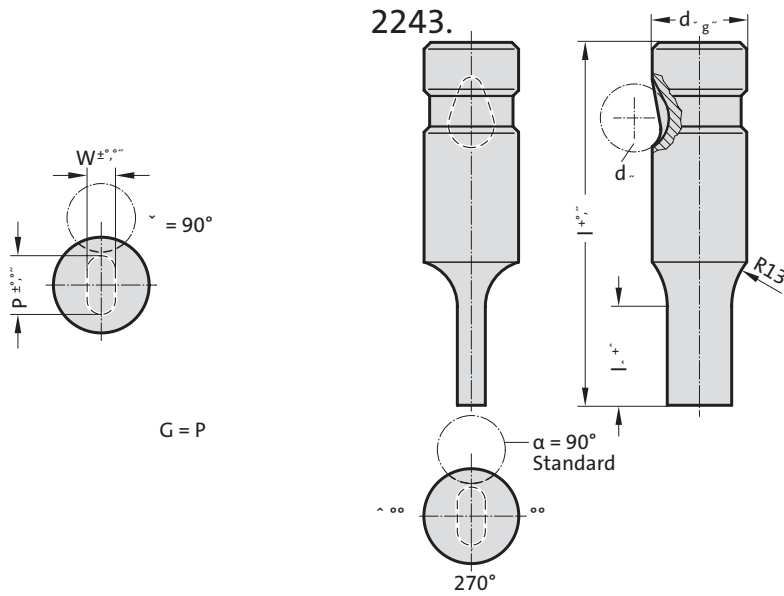

2243. Ball lock punch, stepped, slot, heavy duty

d ₂ / (Order No)	W _{min}	G _{max}	l ₁ / (Order No)*	l / (Order Code character)	63 (C)	71 (D)	80 (E)	90 (F)	100 (G)	110 (H)	125 (J)
10 / (2)	1.6	9.9	13 (1) 19 (2)		●	●	●	●	●	●	●
13 / (3)	4.5	12.9	13 (1) 19 (2)		●	●	●	●	●	●	●
16 / (4)	6	15.9	13 (1) 19 (2) 25 (3)		●	●	●	●	●	●	●
20 / (5)	8	19.9	13 (1) 19 (2) 25 (3)		●	●	●	●	●	●	●
25 / (6)	10	24.9	13 (1) 19 (2) 25 (3)			●	●	●	●	●	●
32 / (7)	12.5	31.9	13 (1) 19 (2) 25 (3)			●	●	●	●	●	●
40 / (9)	14	39.9	19 (2) 25 (3) 30 (4)				●	●	●	●	●

*l₁=10 where W < 2.20

Ordering-code (example):

22 43 . 3 E 2 . 1215 . 0915 B

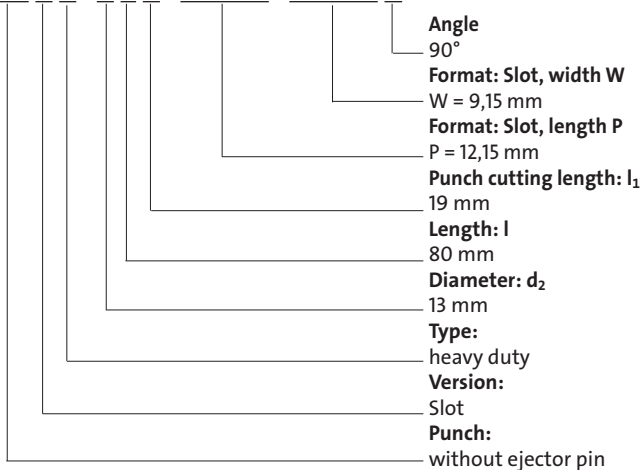

Order code character
 = (B)
 = 0915
 = 1215
Order No
 = (2)
Order code character
 = (E)
Order No
 = (3)
Order No
 = (3)
Order No
 = (4)
 = 22

Material:

HSS
 Hardness 62 ± 2 HRC

Execution:

Shaft and punch shape fine ground.
 Special dimensions on request.

Ball lock punch, stepped, rectangle with radiussed corners, heavy duty

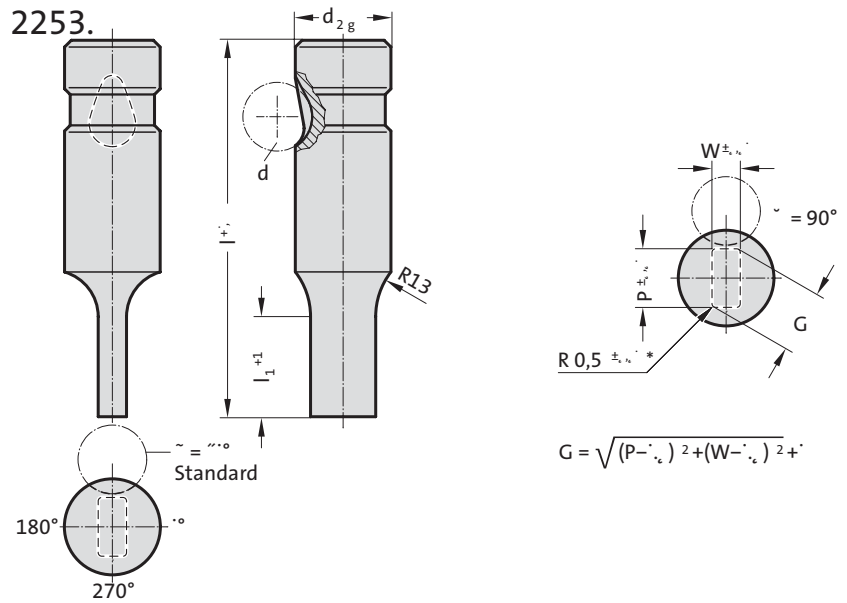

2253. Ball lock punch, stepped, rectangle with radiussed corners, heavy duty

d ₂ / (Order No)	W _{min}	G _{max}	l ₁ / (Order No)*	l / (Order Code character)	63 (C)	71 (D)	80 (E)	90 (F)	100 (G)	110 (H)	125 (J)
10 / (2)	1.6	9.9	13 (1) 19 (2)		●	●	●	●	●	●	●
13 / (3)	4.5	12.9	13 (1) 19 (2)		●	●	●	●	●	●	●
16 / (4)	6	15.9	13 (1) 19 (2) 25 (3)		●	●	●	●	●	●	●
20 / (5)	8	19.9	13 (1) 19 (2) 25 (3)		●	●	●	●	●	●	●
25 / (6)	10	24.9	13 (1) 19 (2) 25 (3)			●	●	●	●	●	●
32 / (7)	12.5	31.9	13 (1) 19 (2) 25 (3)			●	●	●	●	●	●
40 / (9)	14	39.9	19 (2) 25 (3) 30 (4)				●	●	●	●	●

*l₁=10 where W < 2.20



Material:

HSS
Hardness 62 ± 2 HRC

Execution:

Shaft and punch shape fine ground.
Special dimensions on request.
* For other radius options, see standardised special shapes.

Ordering-code (example):

2 2 5 3 . 2 F 1 . 0 6 5 0 . 0 4 5 0 B

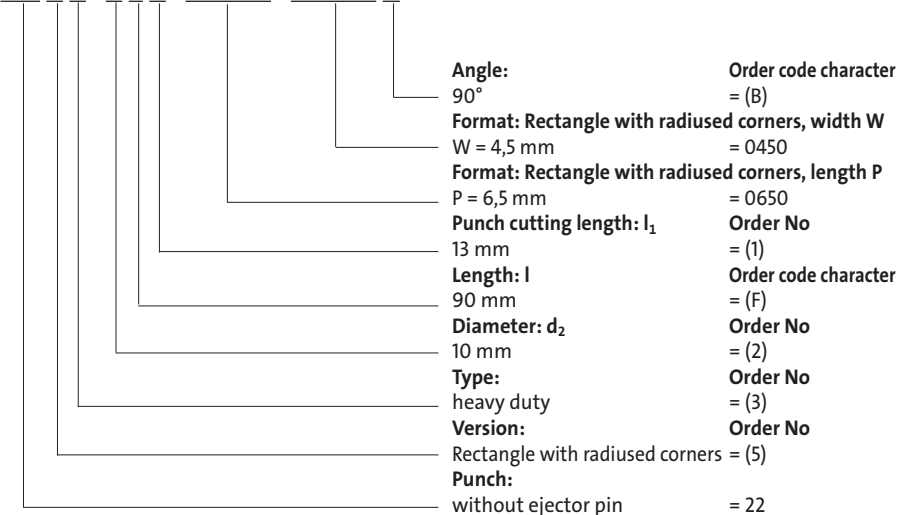

Ball lock punch, blank, with ejector pin, heavy duty

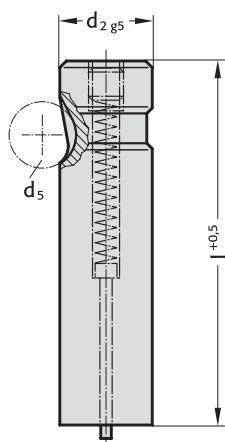

2703. Ball lock punch, blank, with ejector pin, heavy duty

d ₂ / (Order No)	d ₅	l / (Order Code character)	63 (C)	71 (D)	80 (E)	90 (F)	100 (G)	110 (H)	125 (J)
10 / (2)	10		●	●	●	●	●		
13 / (3)	12		●	●	●	●		●	●
16 / (4)	12		●	●	●	●	●	●	●
20 / (5)	12		●	●	●	●	●	●	●
25 / (6)	12			●	●	●	●	●	●
32 / (7)	12			●	●	●	●	●	●
40 / (9)	12				●	●	●	●	●

Ordering-code (example):

2703.7G

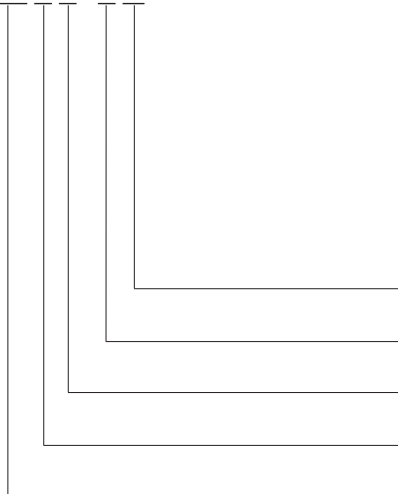

Length: l
100 mm
Diameter: d₂
32 mm
Type:
heavy duty
Version:
blank
Punch:
with ejector pin

Order code character
= (G)
Order No
= (7)
Order No
= (3)
Order No
= (0)
= 27

Material:

HSS
Hardness 62 ± 2 HRC

Execution:

Shaft fine ground.
Special dimensions on request.

Ball lock punch, stepped, round, with ejector pin, heavy duty



2713.

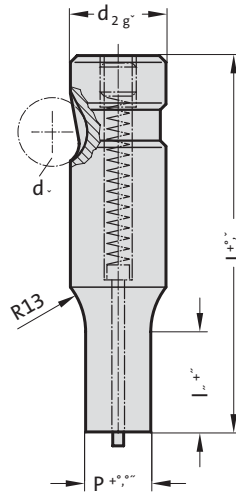

2713. Ball lock punch, stepped, round, with ejector pin, heavy duty

d ₂ / (Order No)	d ₅	P	l ₁ / (Order No)*	l / (Order Code character)	63 (C)	71 (D)	80 (E)	90 (F)	100 (G)	110 (H)	125 (J)
10 / (2)	10	1.6 - 9.9	13 (1) 19 (2)		●	●	●	●	●	●	●
13 / (3)	12	5 - 12.9	13 (1) 19 (2)		●	●	●	●	●	●	●
16 / (4)	12	8 - 15.9	13 (1) 19 (2) 25 (3)		●	●	●	●	●	●	●
20 / (5)	12	12 - 19.9	13 (1) 19 (2) 25 (3)		●	●	●	●	●	●	●
25 / (6)	12	16 - 24.9	13 (1) 19 (2) 25 (3)			●	●	●	●	●	●
32 / (7)	12	24 - 31.9	13 (1) 19 (2) 25 (3)			●	●	●	●	●	●
40 / (9)	12	30 - 39.9	19 (2) 25 (3) 30 (4)				●	●	●	●	●

*l₁=10 where P < 2.20



Material:

HSS
Hardness 62 ± 2 HRC

Execution:

Shaft and punch diameter fine ground.
Special dimensions on request.

Ordering-code (example):

2713.3C1.0550

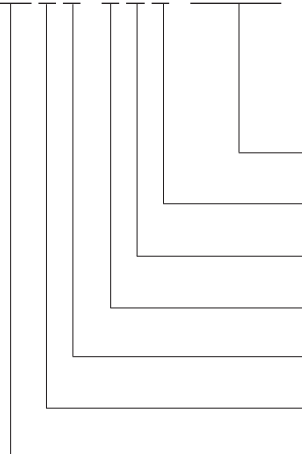

Format: Round
P = Ø 5,5 mm
Punch cutting length: l₁
13 mm
length: l
63 mm
diameter: d₂
13 mm
Type:
heavy duty
Version:
Round
Punch:
with ejector pin

= 0550
Order No
= (1)
Order code character
= (C)
Order No
= (3)
Order No
= (3)
Order No
= (1)
= 27



Ball lock punch, stepped, square, with ejector pin, heavy duty

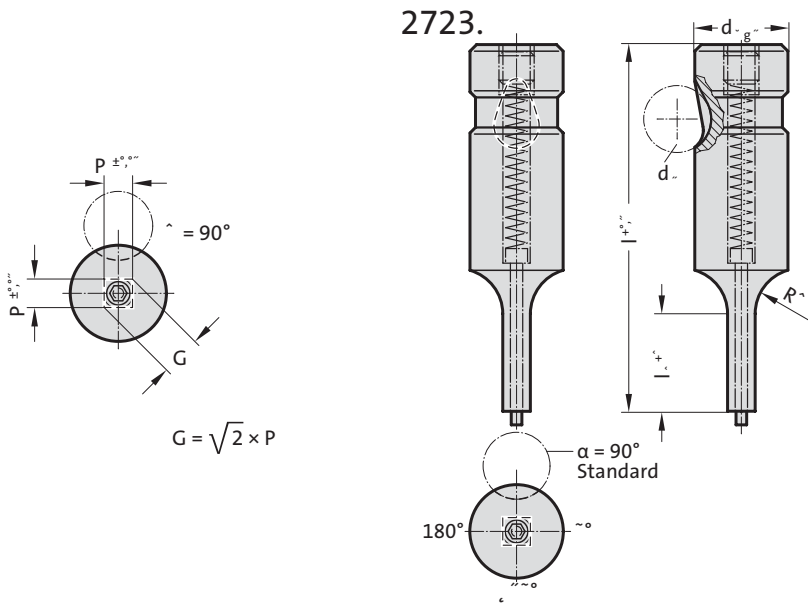

2723. Ball lock punch, stepped, square, with ejector pin, heavy duty

d ₂ / (Order No)	d ₅	P _{min}	G _{max}	l ₁ / (Order No)*	l / (Order Code character)	63 (C)	71 (D)	80 (E)	90 (F)	100 (G)	110 (H)	125 (J)
10 / (2)	10	1.6	9.9	13 (1) 19 (2)		●	●	●	●	●	●	●
13 / (3)	12	4.5	12.9	13 (1) 19 (2)		●	●	●	●	●	●	●
16 / (4)	12	6	15.9	13 (1) 19 (2) 25 (3)		●	●	●	●	●	●	●
20 / (5)	12	8	19.9	13 (1) 19 (2) 25 (3)		●	●	●	●	●	●	●
25 / (6)	12	10	24.9	13 (1) 19 (2) 25 (3)			●	●	●	●	●	●
32 / (7)	12	12.5	31.9	13 (1) 19 (2) 25 (3)			●	●	●	●	●	●
40 / (9)	12	14	39.9	19 (2) 25 (3) 30 (4)			●	●	●	●	●	●

*l₁=10 where P < 2.20

Ordering-code (example):

27 23 . 2 F 1 . 0 6 5 0 B

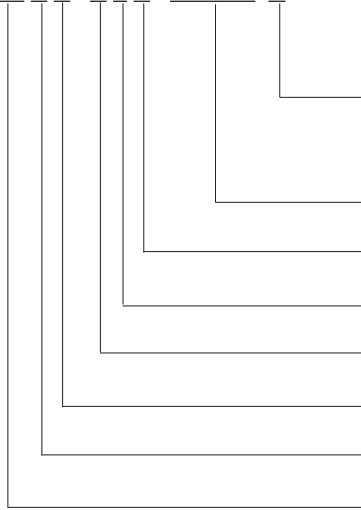

Angle:
90°

Format: Square, length P
P = 6,5 mm

Punch cutting length: l₁
13 mm

Length: l
90 mm

Diameter: d₂
10 mm

Type:
heavy duty

Version:
Square

Punch:
with ejector pin

Order code character
= (B)

= 0650

Order No
= (1)

Order code character
= (F)

Order No
= (2)

Order No
= (3)

Order No
= (2)

= 27

Material:

HSS

Hardness 62 ± 2 HRC

Execution:

Shaft and punch shape fine ground.
Special dimensions on request.

Ball lock punch, stepped, rectangular, with ejector pin, heavy duty

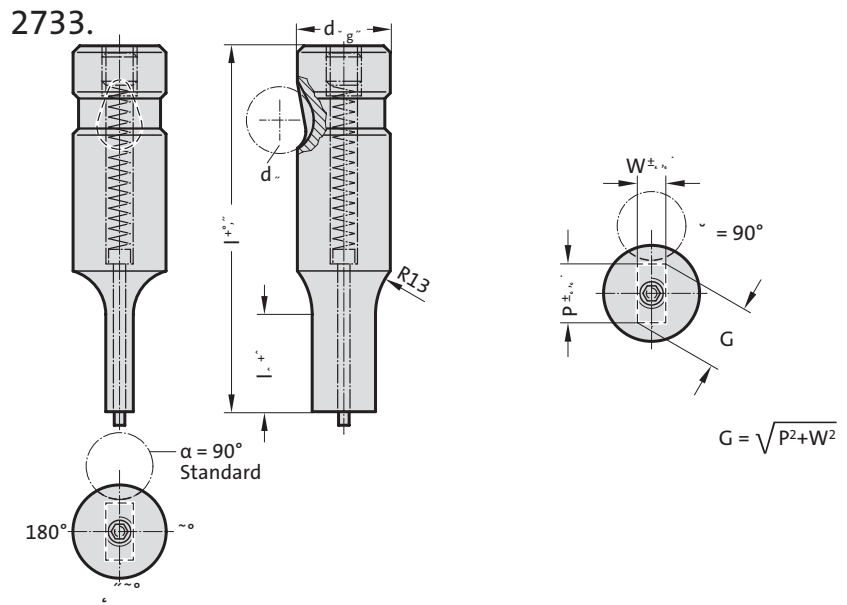

2733. Ball lock punch, stepped, rectangular, with ejector pin, heavy duty

d ₂ / (Order No)	d ₅	W _{min}	G _{max}	l ₁ / (Order No)*	l / (Order Code character)	63 (C)	71 (D)	80 (E)	90 (F)	100 (G)	110 (H)	125 (J)
10 / (2)	10	1.6	9.9	13 (1) 19 (2)		●	●	●	●	●	●	●
13 / (3)	12	4.5	12.9	13 (1) 19 (2)		●	●	●	●	●	●	●
16 / (4)	12	6	15.9	13 (1) 19 (2) 25 (3)		●	●	●	●	●	●	●
20 / (5)	12	8	19.9	13 (1) 19 (2) 25 (3)		●	●	●	●	●	●	●
25 / (6)	12	10	24.9	13 (1) 19 (2) 25 (3)			●	●	●	●	●	●
32 / (7)	12	12.5	31.9	13 (1) 19 (2) 25 (3)			●	●	●	●	●	●
40 / (9)	12	14	39.9	19 (2) 25 (3) 30 (4)			●	●	●	●	●	●

*l₁=10 where W < 2.20



Material:

HSS
Hardness 62 ± 2 HRC

Execution:

Shaft and punch shape fine ground.
Special dimensions on request.

Ordering-code (example):

2733.7F2.1400.1250B

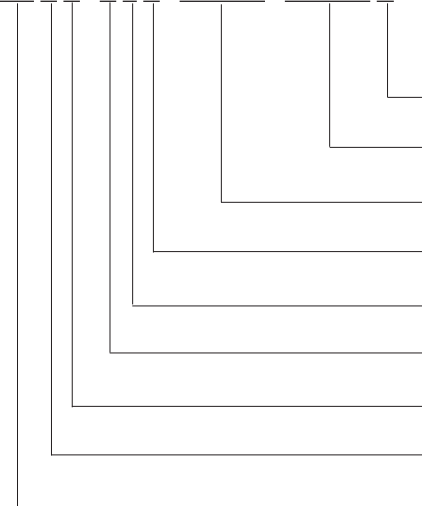

Angle: 90° **Order code character** = (B)
Format: Rectangular, width W W = 12,5 mm = 1250
Format: Rectangular, length P P = 14,0 mm = 1400
Punch cutting length: l₁ 19 mm **Order No** = (2)
Length: l 90 mm **Order code character** = (F)
Diameter: d₂ 32 mm **Order No** = (7)
Type: heavy duty **Order No** = (3)
Version: Rectangular **Order No** = (3)
Punch: with ejector pin = 27

Ball lock punch, stepped, slot, with ejector pin, heavy duty

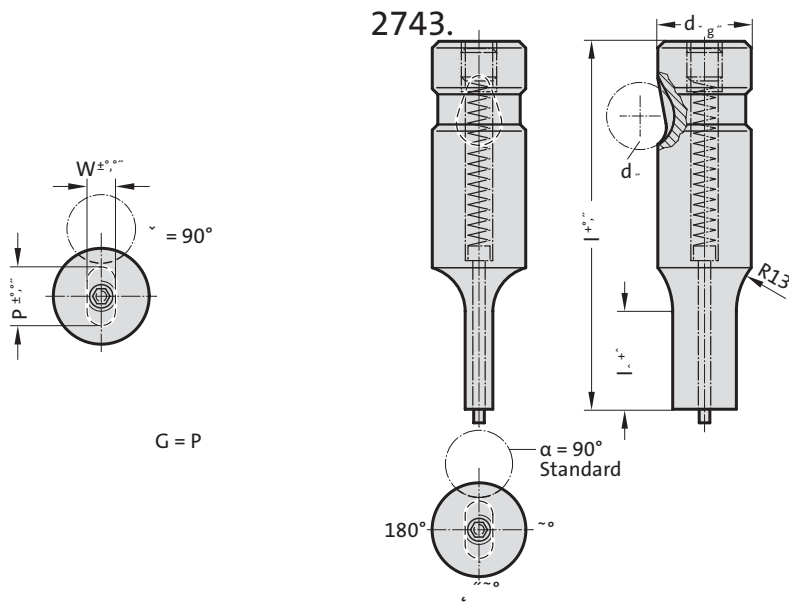

2743. Ball lock punch, stepped, slot, with ejector pin, heavy duty

d ₂ / (Order No)	d ₅	W _{min}	G _{max}	l ₁ / (Order No)*	l / (Order Code character)	63 (C)	71 (D)	80 (E)	90 (F)	100 (G)	110 (H)	125 (J)
10 / (2)	10	1.6	9.9	13 (1) 19 (2)		●	●	●	●	●	●	●
13 / (3)	12	4.5	12.9	13 (1) 19 (2)		●	●	●	●	●	●	●
16 / (4)	12	6	15.9	13 (1) 19 (2) 25 (3)		●	●	●	●	●	●	●
20 / (5)	12	8	19.9	13 (1) 19 (2) 25 (3)		●	●	●	●	●	●	●
25 / (6)	12	10	24.9	13 (1) 19 (2) 25 (3)			●	●	●	●	●	●
32 / (7)	12	12.5	31.9	13 (1) 19 (2) 25 (3)			●	●	●	●	●	●
40 / (9)	12	14	39.9	19 (2) 25 (3) 30 (4)				●	●	●	●	●

*l₁=10 where W < 2.20

Ordering-code (example):

27 43 . 2 F1 . 0 6 50 . 0 4 50 B

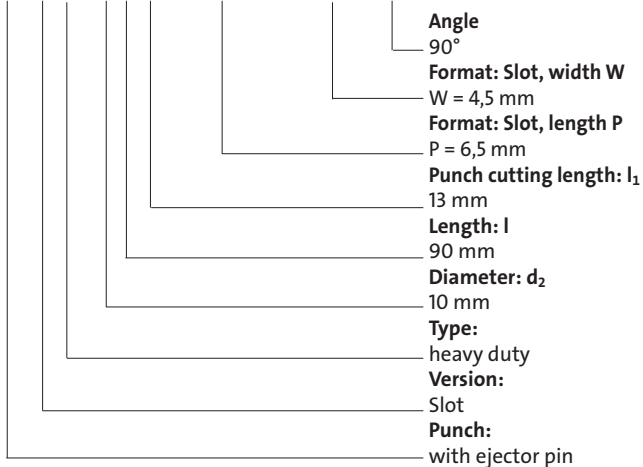

Order code character
= (B)
= 0450
= 0650
Order No
= (1)
Order code character
= (F)
Order No
= (2)
Order No
= (3)
Order No
= (4)
= 27

Material:

HSS
Hardness 62 ± 2 HRC

Execution:

Shaft and punch shape fine ground.
Special dimensions on request.

Ball lock punch, stepped, rectangle with radiussed corners, with ejector pin, heavy duty

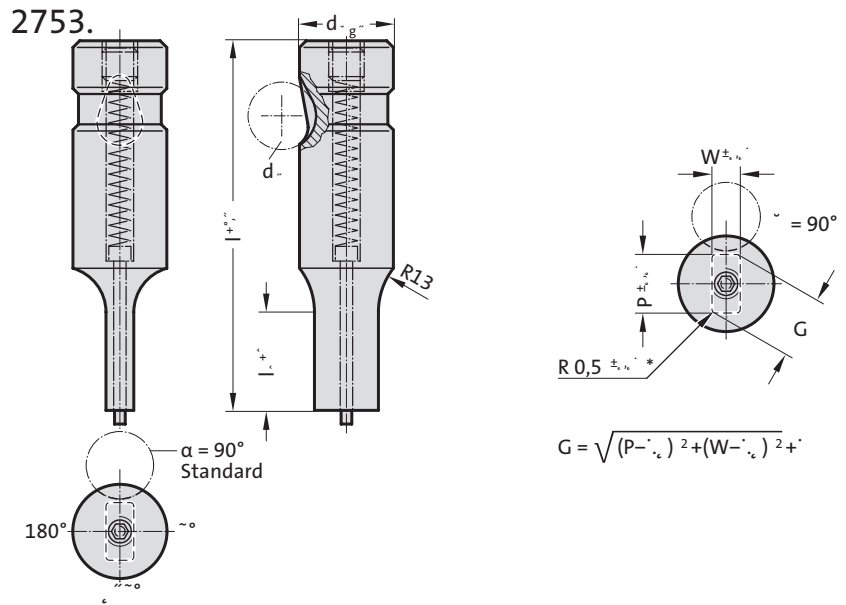

2753. Ball lock punch, stepped, rectangle with radiussed corners, with ejector pin, heavy duty

d ₂ / (Order No)	d ₅	W _{min}	G _{max}	l ₁ / (Order No)*	l / (Order Code character)	63 (C)	71 (D)	80 (E)	90 (F)	100 (G)	110 (H)	125 (J)
10 / (2)	10	1.6	9.9	13 (1) 19 (2)		●	●	●	●	●	●	●
13 / (3)	12	4.5	12.9	13 (1) 19 (2)		●	●	●	●	●	●	●
16 / (4)	12	6	15.9	13 (1) 19 (2) 25 (3)		●	●	●	●	●	●	●
20 / (5)	12	8	19.9	13 (1) 19 (2) 25 (3)		●	●	●	●	●	●	●
25 / (6)	12	10	24.9	13 (1) 19 (2) 25 (3)			●	●	●	●	●	●
32 / (7)	12	12.5	31.9	13 (1) 19 (2) 25 (3)			●	●	●	●	●	●
40 / (9)	12	14	39.9	19 (2) 25 (3) 30 (4)				●	●	●	●	●

*l₁=10 where W < 2.20



Material:

HSS
Hardness 62 ± 2 HRC

Execution:

Shaft and punch shape fine ground.
Special dimensions on request.
* For other radius options, see standardised special shapes.

Ordering-code (example):

2753.3F1.1215.0915B

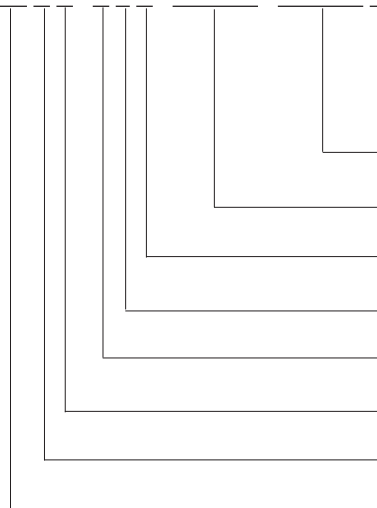

Angle: 90° Order code character = (B)
Format: Rectangle with radiussed corners, width W = 9,15 mm Order code character = 0915
Format: Rectangle with radiussed corners, length P = 12,15 mm Order code character = 1215
Punch cutting length: l₁ = 13 mm Order No = (1)
Length: l = 90 mm Order code character = (F)
Diameter: d₂ = 13 mm Order No = (3)
Type: heavy duty Order No = (3)
Version: Rectangle with radiussed corners = (5)
Punch: with ejector pin = 27

Ball lock punch, punch larger than shaft, blank, heavy duty

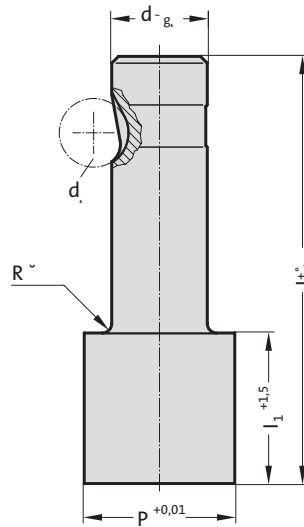
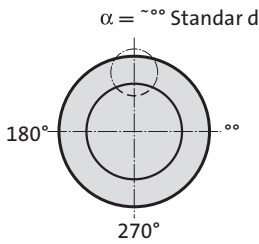

2205. Ball lock punch, punch larger than shaft, blank, heavy duty

d ₂ / (Order No)	d ₅	P	l ₁ / (Order No)	l / (Order Code character)	80 (E)	90 (F)	100 (G)
13 / (3)	12	32	19 (2) 30 (4)		●	●	●
16 / (4)	12	38	19 (2) 30 (4)		●	●	●
20 / (5)	12	40	19 (2) 30 (4)		●	●	●
25 / (6)	12	44	19 (2) 30 (4)		●	●	●
32 / (7)	12	50	19 (2) 30 (4)		●	●	●
40 / (9)	12	56	19 (2) 30 (4)		●	●	●

Ordering-code (example):

2205.7G4.5000

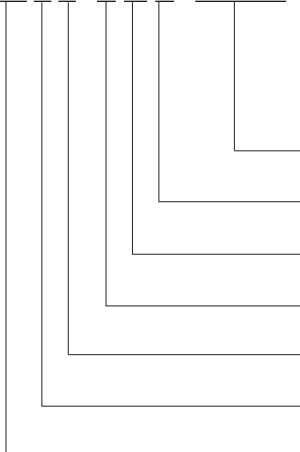

Format: Round
 P = Ø 50,0 mm
Punch cutting length: l₁
 30 mm
length: l
 100 mm
diameter: d₂
 32 mm
Type:
 punch larger, heavy duty
Version:
 Blank
Punch:
 without ejector pin

= 5000
Order No
 = (4)
Order code character
 = (G)
Order No
 = (7)
Order No
 = (5)
Order No
 = (0)
 = 22

Material:

HSS
 Hardness 62 ± 2 HRC

Execution:

Shaft and punch diameter fine ground.
 Special dimensions on request.

Ball lock punch, punch larger than shaft, round, heavy duty

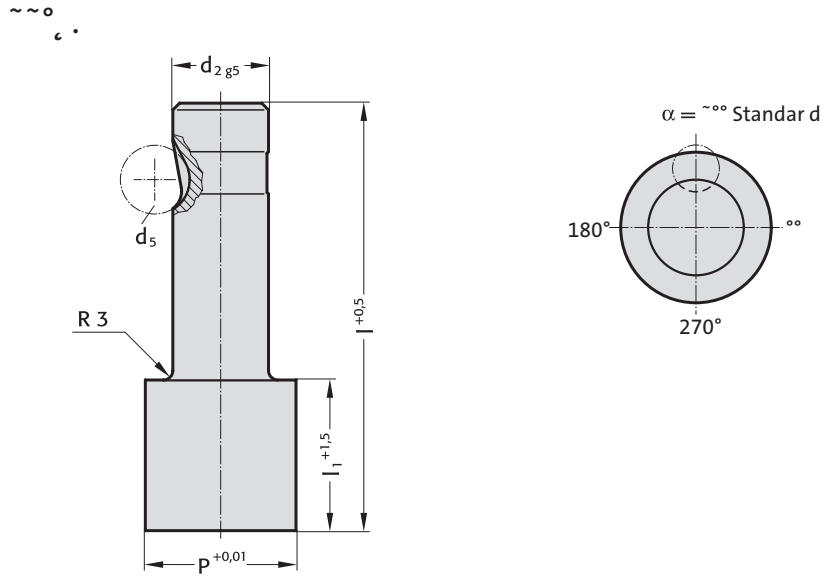

2215. Ball lock punch, punch larger than shaft, round, heavy duty

d ₂ / (Order No)	d ₅	P	l ₁ / (Order No)	l / (Order Code character)	80 (E)	90 (F)	100 (G)
13 / (3)	12	13 - 32	19 (2) 30 (4)		●	●	●
16 / (4)	12	16 - 38	19 (2) 30 (4)		●	●	●
20 / (5)	12	20 - 40	19 (2) 30 (4)		●	●	●
25 / (6)	12	25 - 44	19 (2) 30 (4)		●	●	●
32 / (7)	12	32 - 50	19 (2) 30 (4)		●	●	●
40 / (9)	12	40 - 56	19 (2) 30 (4)		●	●	●

Material:

HSS
Hardness 62 ± 2 HRC

Execution:

Shaft and punch diameter fine ground.
Special dimensions on request.

Ordering-code (example):

2 2 1 5 . 7 G 2 . 3 2 1 0

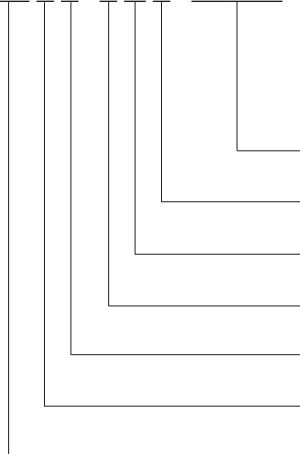

Format: Round
P = Ø 32,1 mm
Punch cutting length: l₁
19 mm
length: l
100 mm
diameter: d₂
32 mm
Type:
punch larger, heavy duty
Version:
Round
Punch:
without ejector pin

= 3210
Order No
= (2)
Order code character
= (G)
Order No
= (7)
Order No
= (5)
Order No
= (1)
= 22



Ball lock punch, punch larger than shaft, square, heavy duty

2225.

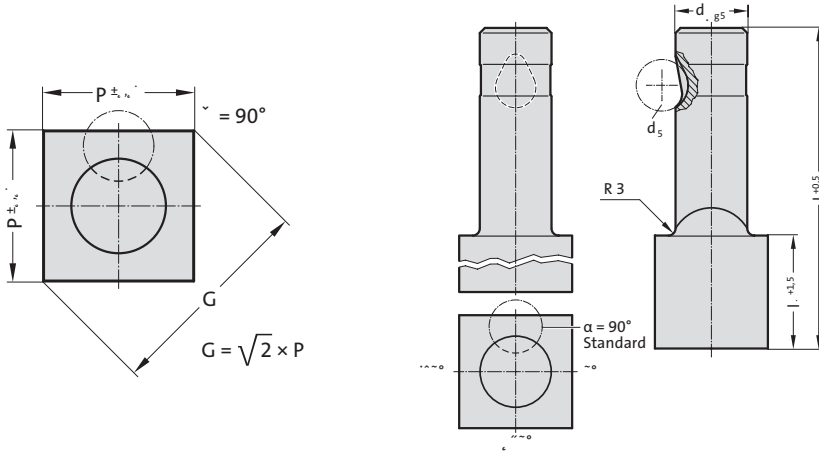

2225. Ball lock punch, punch larger than shaft, square, heavy duty

d ₂ / (Order No)	d ₅	P _{min}	G _{max}	l ₁ / (Order No)	l / (Order Code character)	80 (E)	90 (F)	100 (G)
13 / (3)	12	9.19	32	19 (2) 30 (4)		●	●	●
16 / (4)	12	11.31	38	19 (2) 30 (4)		●	●	●
20 / (5)	12	14.14	40	19 (2) 30 (4)		●	●	●
25 / (6)	12	17.68	44	19 (2) 30 (4)		●	●	●
32 / (7)	12	22.63	50	19 (2) 30 (4)		●	●	●
40 / (9)	12	28.28	56	19 (2) 30 (4)		●	●	●

Ordering-code (example):

22 25.4 F 4.1150 B

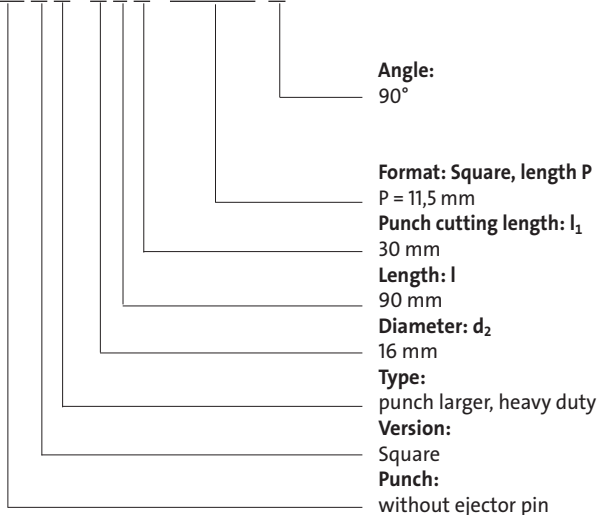

Order code character = (B)

= 1150

Order No = (4)

Order code character = (F)

Order No = (4)

Order No = (5)

Order No = (2)

= 22

Material:

HSS
Hardness 62 ± 2 HRC

Execution:

Shaft and punch shape fine ground.
Special dimensions on request.

Ball lock punch, punch larger than shaft, rectangular, heavy duty



2235.

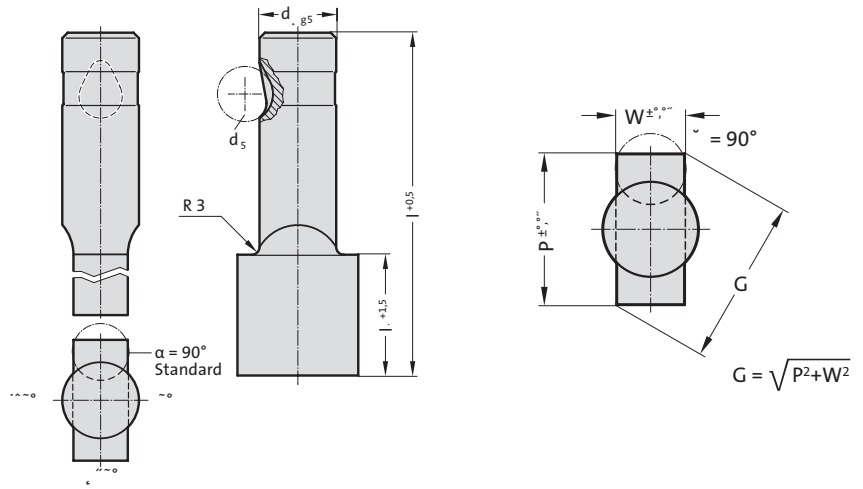

2235. Ball lock punch, punch larger than shaft, rectangular, heavy duty

d ₂ / (Order No)	d ₅	W _{min}	G _{max}	l ₁ / (Order No)	l / (Order Code character)	80 (E)	90 (F)	100 (G)
13 / (3)	12	5	32	19 (2) 30 (4)		●	●	●
16 / (4)	12	6.5	38	19 (2) 30 (4)		●	●	●
20 / (5)	12	8	40	19 (2) 30 (4)		●	●	●
25 / (6)	12	10	44	19 (2) 30 (4)		●	●	●
32 / (7)	12	11.5	50	19 (2) 30 (4)		●	●	●
40 / (9)	12	14	56	19 (2) 30 (4)		●	●	●



Material:

HSS
Hardness 62 ± 2 HRC

Execution:

Shaft and punch shape fine ground.
Special dimensions on request.

Ordering-code (example):

2235.4F4.1400.1100B

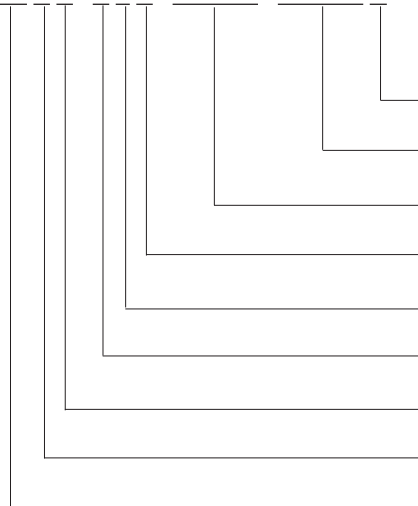

Angle: 90°
Format: Rectangular, width W W = 11,0 mm
Format: Rectangular, length P P = 14 mm
Punch cutting length: l₁ 30 mm
Length: l 90 mm
Diameter: d₂ 16 mm
Type: punch larger, heavy duty
Version: Rectangular
Punch: without ejector pin

Order code character = (B)
Order No = 1100
Order No = 1400
Order code character = (F)
Order No = (4)
Order No = (4)
Order No = (5)
Order No = (3)
Order No = 22

Ball lock punch, punch larger than shaft, slot, heavy duty



2245.

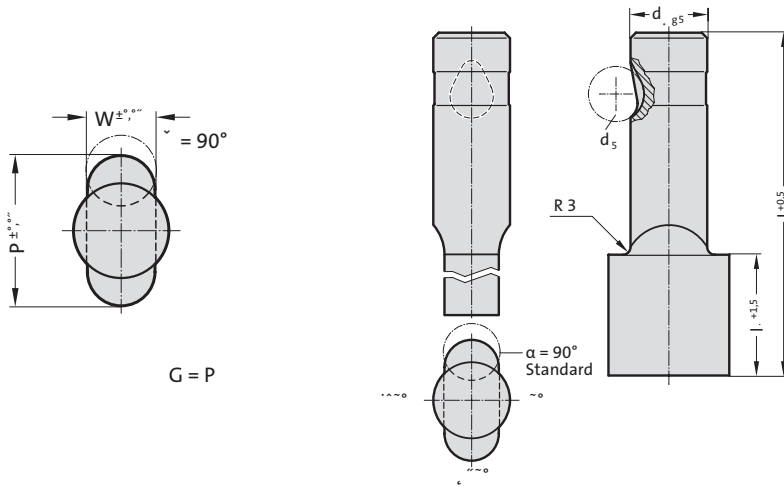

2245. Ball lock punch, punch larger than shaft, slot, heavy duty

d ₂ / (Order No)	d ₅	W _{min}	G _{max}	l ₁ / (Order No)	l / (Order Code character)	80 (E)	90 (F)	100 (G)
13 / (3)	12	5	32	19 (2) 30 (4)		●	●	●
16 / (4)	12	6.5	38	19 (2) 30 (4)		●	●	●
20 / (5)	12	8	40	19 (2) 30 (4)		●	●	●
25 / (6)	12	10	44	19 (2) 30 (4)		●	●	●
32 / (7)	12	11.5	50	19 (2) 30 (4)		●	●	●
40 / (9)	12	14	56	19 (2) 30 (4)		●	●	●

Ordering-code (example):

22 45.7 F 2.38 00.115 0 B

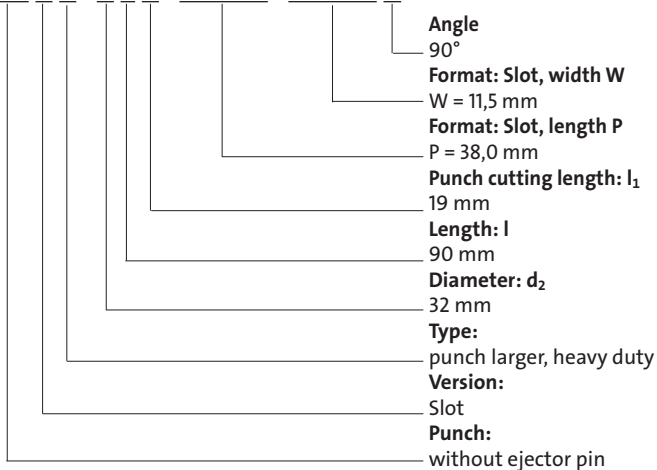

Order code character = (B)
= 1150
= 3800
Order No = (2)
Order code character = (F)
Order No = (7)
Order No = (5)
Order No = (4)
= 22

Material:

HSS
Hardness 62 ± 2 HRC

Execution:

Shaft and punch shape fine ground.
Special dimensions on request.

Ball lock punch, punch larger than shaft, rectangle with radiussed corners, heavy duty



2255.

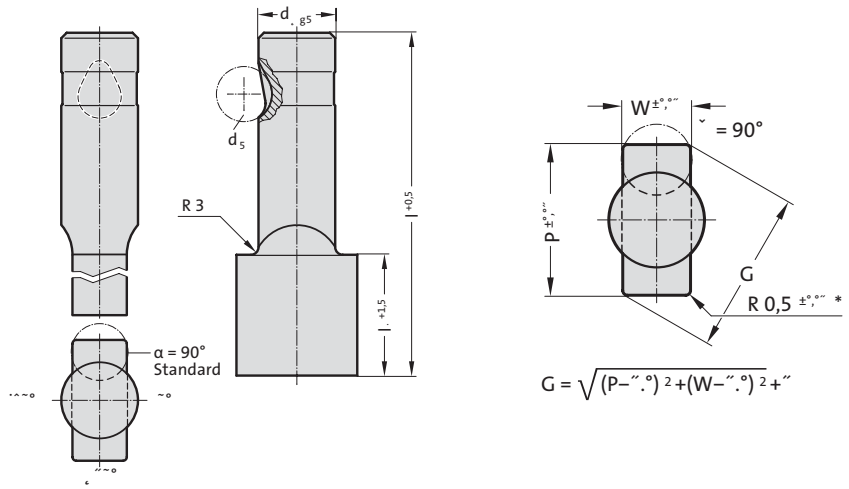

2255. Ball lock punch, punch larger than shaft, rectangle with radiussed corners, heavy duty

d ₂ / (Order No)	d ₅	W _{min}	G _{max}	l ₁ / (Order No)	l / (Order Code character)	80 (E)	90 (F)	100 (G)
13 / (3)	12	5	32	19 (2) 30 (4)		●	●	●
16 / (4)	12	6.5	38	19 (2) 30 (4)		●	●	●
20 / (5)	12	8	40	19 (2) 30 (4)		●	●	●
25 / (6)	12	10	44	19 (2) 30 (4)		●	●	●
32 / (7)	12	11.5	50	19 (2) 30 (4)		●	●	●
40 / (9)	12	14	56	19 (2) 30 (4)		●	●	●



Material:

HSS
Hardness 62 ± 2 HRC

Execution:

Shaft and punch shape fine ground.
Special dimensions on request.
* For other radius options, see standardised special shapes.

Ordering-code (example):

2255.4F2.1400.1100B

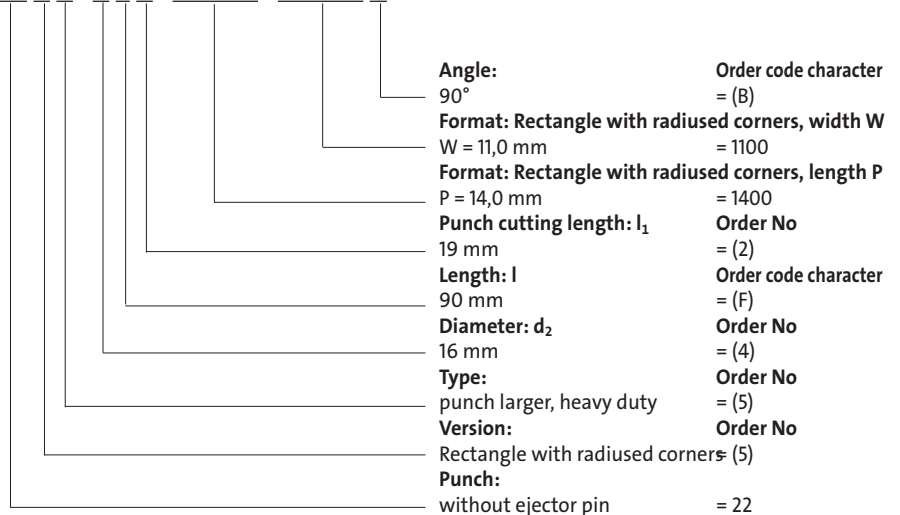

Ball lock punch, punch larger than shaft, blank, with ejector pin, heavy duty

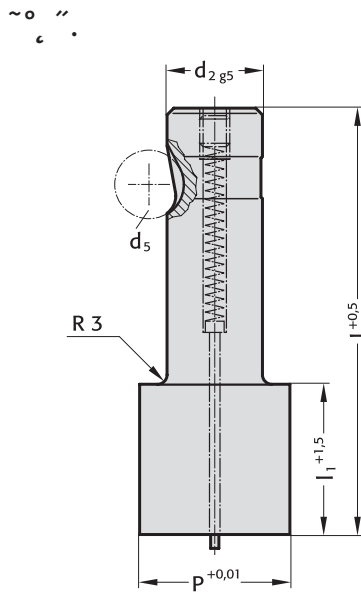
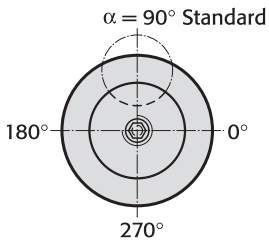

2705. Ball lock punch, punch larger than shaft, blank, with ejector pin, heavy duty

d ₂ / (Order No)	P	l ₁ / (Order No)	l / (Order Code character)	80 (E)	90 (F)	100 (G)
13 / (3)	32	19 (2) 30 (4)		●	●	●
16 / (4)	38	19 (2) 30 (4)		●	●	●
20 / (5)	40	19 (2) 30 (4)		●	●	●
25 / (6)	44	19 (2) 30 (4)		●	●	●
32 / (7)	50	19 (2) 30 (4)		●	●	●
40 / (9)	56	19 (2) 30 (4)		●	●	●



Ordering-code (example):

27 05 . 7 G 4 . 5 0 0 0

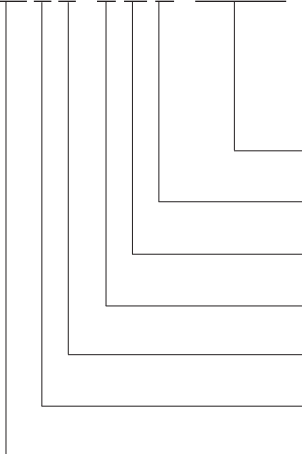

Format: Round
 P = Ø 50,0 mm
Punch cutting length: l₁
 30 mm
length: l
 100 mm
diameter: d₂
 32 mm
Type:
 punch larger, heavy duty
Version:
 Blank
Punch:
 with ejector pin

= 5000
Order No
 = (4)
Order code character
 = (G)
Order No
 = (7)
Order No
 = (5)
Order No
 = (0)
 = 27

Material:

HSS
 Hardness 62 ± 2 HRC

Execution:

Shaft and punch diameter fine ground.
 Special dimensions on request.

Ball lock punch, punch larger than shaft, round, with ejector pin, heavy duty

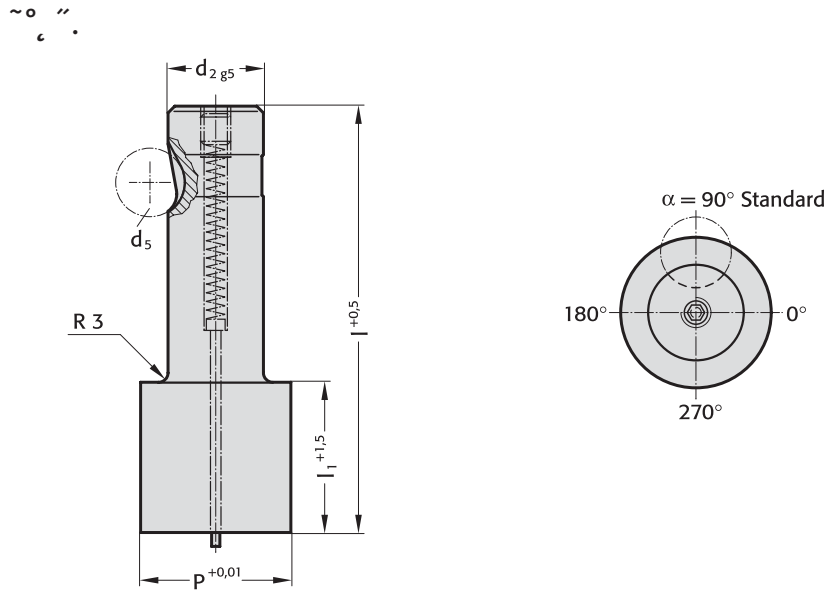

2715. Ball lock punch, punch larger than shaft, round, with ejector pin, heavy duty

d ₂ / (Order No)	d ₅	P	l ₁ / (Order No)	l / (Order Code character)	80 (E)	90 (F)	100 (G)
13 / (3)	12	13 - 32	19 (2) 30 (4)		●	●	●
16 / (4)	12	16 - 38	19 (2) 30 (4)		●	●	●
20 / (5)	12	20 - 40	19 (2) 30 (4)		●	●	●
25 / (6)	12	25 - 44	19 (2) 30 (4)		●	●	●
32 / (7)	12	32 - 50	19 (2) 30 (4)		●	●	●
40 / (9)	12	40 - 56	19 (2) 30 (4)		●	●	●



Material:

HSS
Hardness 62 ± 2 HRC

Execution:

Shaft and punch diameter fine ground.
Special dimensions on request.

Ordering-code (example):

27 15. 7 G 2. 3 2 1 0

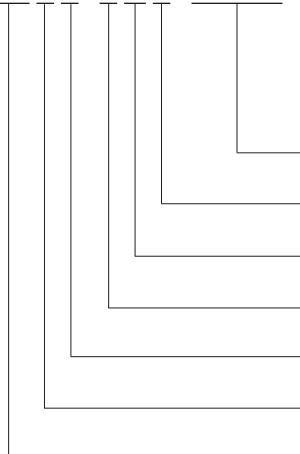

Format: Round
P = Ø 32,1 mm
Punch cutting length: l₁
19 mm
length: l
100 mm
diameter: d₂
32 mm
Type:
punch larger, heavy duty
Version:
Round
Punch:
with ejector pin

= 3210
Order No
= (2)
Order code character
= (G)
Order No
= (7)
Order No
= (5)
Order No
= (1)
= 27

Ball lock punch, punch larger than shaft, square, with ejector pin, heavy duty

2725.

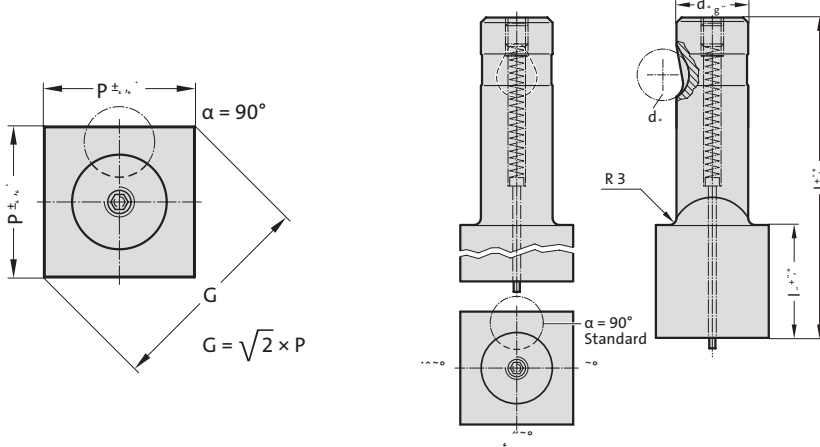

2725. Ball lock punch, punch larger than shaft, square, with ejector pin, heavy duty

d ₂ / (Order No)	d _s	P _{min}	G _{max}	l ₁ / (Order No)	l / (Order Code character)	80 (E)	90 (F)	100 (G)
13 / (3)	12	9.19	32	19 (2) 30 (4)		●	●	●
16 / (4)	12	11.31	38	19 (2) 30 (4)		●	●	●
20 / (5)	12	14.14	40	19 (2) 30 (4)		●	●	●
25 / (6)	12	17.68	44	19 (2) 30 (4)		●	●	●
32 / (7)	12	22.63	50	19 (2) 30 (4)		●	●	●
40 / (9)	12	28.28	56	19 (2) 30 (4)		●	●	●



Ordering-code (example):

27 25.4 F 4.25 00 B

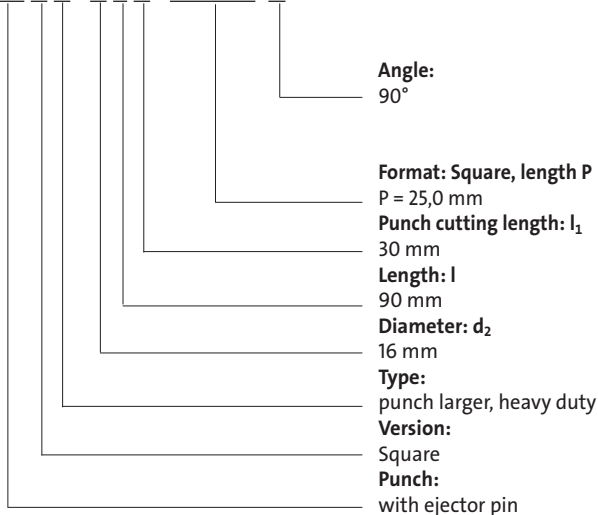

Angle:
90°

Format: Square, length P
P = 25,0 mm

Punch cutting length: l₁
30 mm

Length: l
90 mm

Diameter: d₂
16 mm

Type:
punch larger, heavy duty

Version:
Square

Punch:
with ejector pin

Order code character
= (B)

= 2500
Order No
= (4)

Order code character
= (F)

Order No
= (4)

Order No
= (5)

Order No
= (2)

= 27

Material:

HSS
Hardness 62 ± 2 HRC

Execution:

Shaft and punch shape fine ground.
Special dimensions on request.

Ball lock punch, punch larger than shaft, rectangular, with ejector pin, heavy duty



2735.

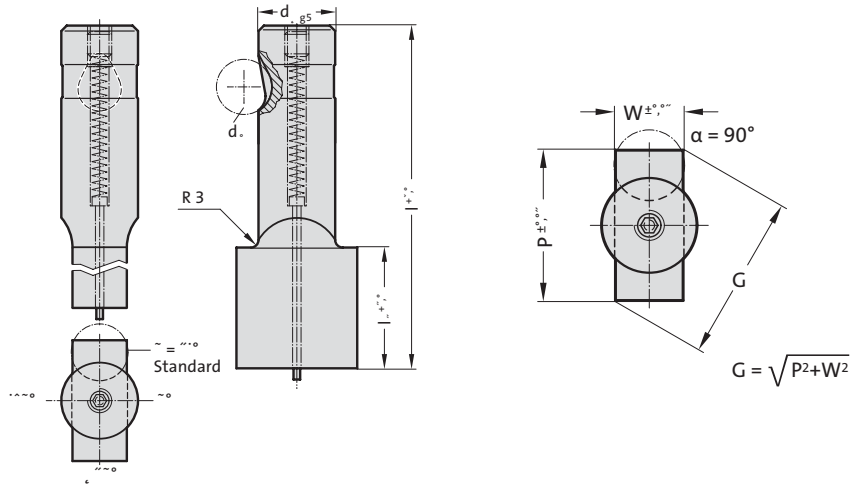

2735. Ball lock punch, punch larger than shaft, rectangular, with ejector pin, heavy duty

d ₂ / (Order No)	d ₅	W _{min}	G _{max}	l ₁ / (Order No)	l / (Order Code character)	80 (E)	90 (F)	100 (G)
13 / (3)	12	5	32	19 (2) 30 (4)		●	●	●
16 / (4)	12	6.5	38	19 (2) 30 (4)		●	●	●
20 / (5)	12	8	40	19 (2) 30 (4)		●	●	●
25 / (6)	12	10	44	19 (2) 30 (4)		●	●	●
32 / (7)	12	11.5	50	19 (2) 30 (4)		●	●	●
40 / (9)	12	14	56	19 (2) 30 (4)		●	●	●



Material:

HSS
Hardness 62 ± 2 HRC

Execution:

Shaft and punch shape fine ground.
Special dimensions on request.

Ordering-code (example):

2735.4F4.1400.1100B

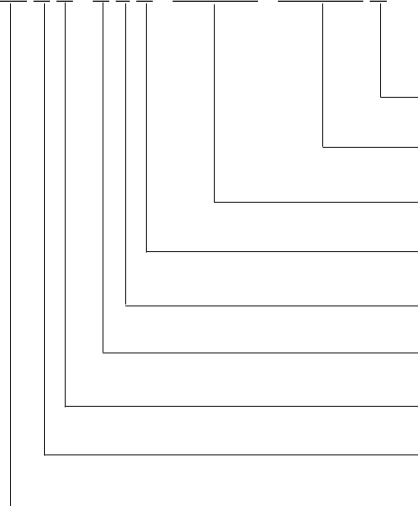

Angle: 90° **Order code character** = (B)
Format: Rectangular, width W W = 11,0 mm = 1100
Format: Rectangular, length P P = 14,0 mm = 1400
Punch cutting length: l₁ 30 mm **Order No** = (4)
Length: l 90 mm **Order code character** = (F)
Diameter: d₂ 16 mm **Order No** = (4)
Type: punch larger, heavy duty **Order No** = (5)
Version: Rectangular **Order No** = (3)
Punch: with ejector pin = 27

Ball lock punch, punch larger than shaft, slot, with ejector pin, heavy duty

2745.

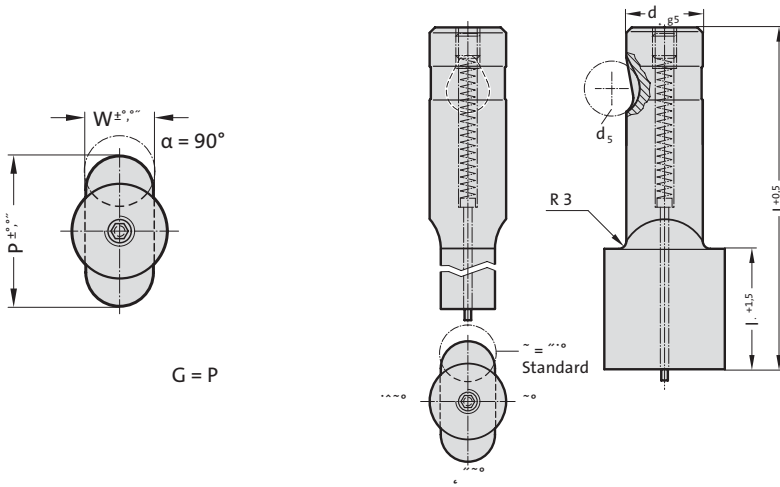

2745. Ball lock punch, punch larger than shaft, slot, with ejector pin, heavy duty

d ₂ / (Order No)	d ₅	W _{min}	G _{max}	l ₁ / (Order No)	l / (Order Code character)	80 (E)	90 (F)	100 (G)
13 / (3)	12	5	32	19 (2) 30 (4)		●	●	●
16 / (4)	12	6.5	38	19 (2) 30 (4)		●	●	●
20 / (5)	12	8	40	19 (2) 30 (4)		●	●	●
25 / (6)	12	10	44	19 (2) 30 (4)		●	●	●
32 / (7)	12	11.5	50	19 (2) 30 (4)		●	●	●
40 / (9)	12	14	56	19 (2) 30 (4)		●	●	●



Ordering-code (example):

27 45 . 4 F 4 . 14 00 . 110 0 B

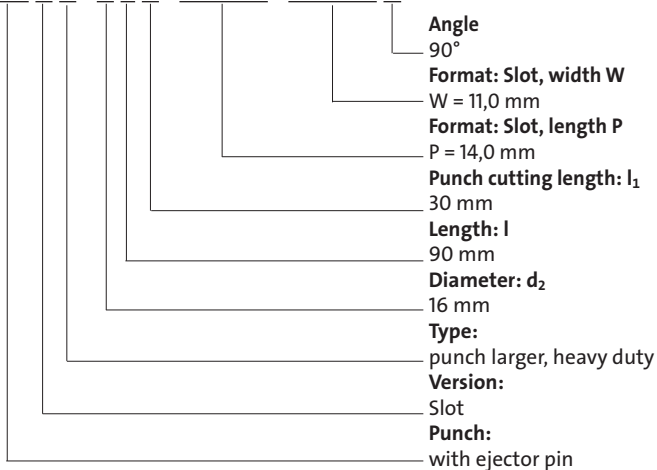

Order code character = (B)
= 1100
= 1400
Order No = (4)
Order code character = (F)
Order No = (4)
Order No = (5)
Order No = (4)
= 27

Material:

HSS
Hardness 62 ± 2 HRC

Execution:

Shaft and punch shape fine ground.
Special dimensions on request.

Ball lock punch, punch larger than shaft, rectangle with radiussed corners, with ejector pin, heavy duty



2755.

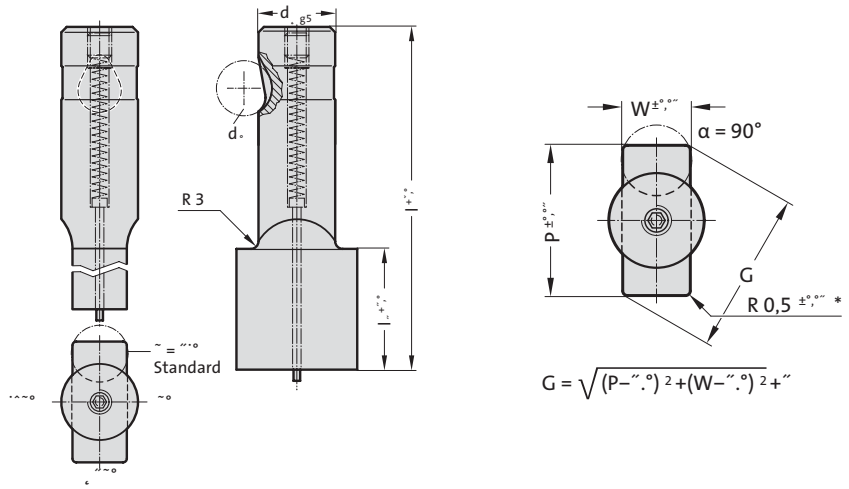

2755. Ball lock punch, punch larger than shaft, rectangle with radiussed corners, with ejector pin, heavy duty

d_2 / (Order No)	d_s	W_{min}	G_{max}	l_1 / (Order No)	l / (Order Code character)	80 (E)	90 (F)	100 (G)
13 / (3)	12	5	32	19 (2) 30 (4)		●	●	●
16 / (4)	12	6.5	38	19 (2) 30 (4)		●	●	●
20 / (5)	12	8	40	19 (2) 30 (4)		●	●	●
25 / (6)	12	10	44	19 (2) 30 (4)		●	●	●
32 / (7)	12	11.5	50	19 (2) 30 (4)		●	●	●
40 / (9)	12	14	56	19 (2) 30 (4)		●	●	●



Material:

HSS
Hardness 62 ± 2 HRC

Execution:

Shaft and punch shape fine ground.
Special dimensions on request.
* For other radius options, see standardised special shapes.

Ordering-code (example):

2755.3F2.1215.1100B

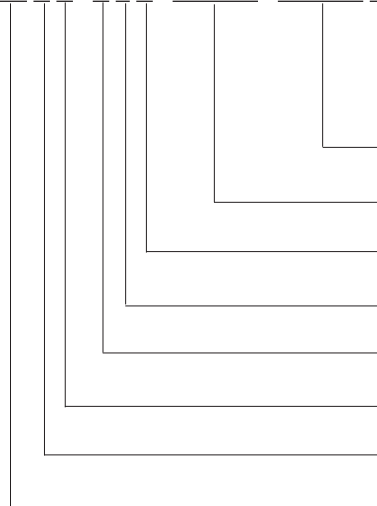

Angle: 90°
Order code character = (B)

Format: Rectangle with radiussed corners, width W = 11,0 mm
= 1100

Format: Rectangle with radiussed corners, length P = 12,15 mm
= 1215

Punch cutting length: l_1 = 19 mm
Order No = (2)

Length: l = 90 mm
Order code character = (F)

Diameter: d_2 = 13 mm
Order No = (3)

Type: punch larger, heavy duty
Order No = (5)

Version: Rectangle with radiussed corners
Order No = (5)

Punch: with ejector pin
= 27



Ball lock pilot pin, with tapered tip, heavy duty

2263.

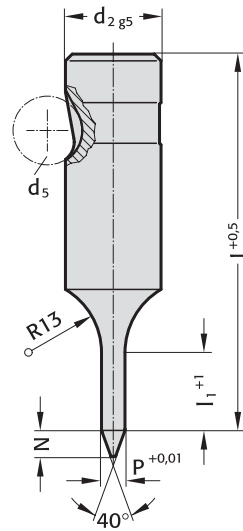

2263. Ball lock pilot pin, with tapered tip, heavy duty

d ₂ / (Order No)	d ₅	P	l ₁ / (Order No)	N	l / (Order Code character)	71 (D)	80 (E)	90 (F)	100 (G)	110 (H)	125 (J)	140 (K)	150 (L)
10 / (2)	10	5,9-9,9	19 (2)	8		●	●	●	●	●			
13 / (3)	12	9,9-12,9	19 (2)	10		●	●	●	●	●	●	●	
16 / (4)	12	12,9-15,9	25 (3)	15		●	●	●	●	●	●	●	●
20 / (5)	12	15,9-19,9	25 (3)	20		●	●	●	●	●	●	●	●
25 / (6)	12	19,9-24,9	25 (3)	25			●	●	●	●	●	●	●
32 / (7)	12	24,9-31,9	25 (3)	30			●	●	●	●	●	●	●
40 / (9)	12	31,9-39,9	30 (4)	40			●	●	●	●	●	●	●

Ordering-code (example):

2263.4G3.1400

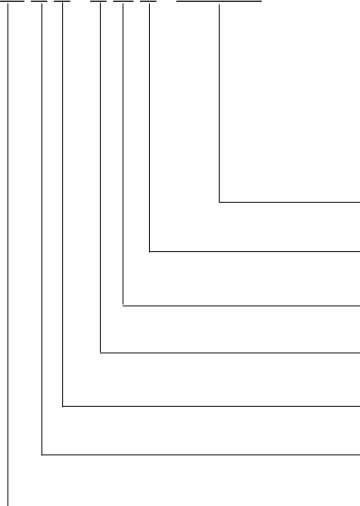

Format: Round
 P = Ø 14,0 mm = 1400
Punch cutting length: l₁
 25 mm = (3)
Length: l
 100 mm = (G)
Diameter: d₂
 16 mm = (4)
Type:
 heavy = (3)
Version:
 Pilot pin with tapered tip = (6)
Punch:
 without ejector pin = 22

Material:

HSS
 Hardness 62 ± 2 HRC

Execution:

Shaft and pilot pin fine ground.
 Special dimensions on request.

Ball lock pilot pin, with parabolic tip, heavy duty



2273.

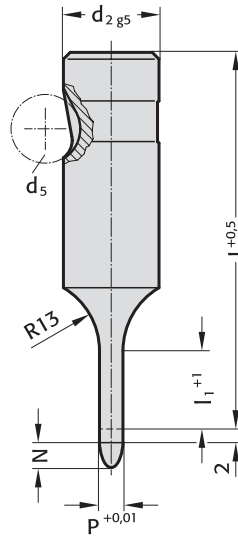

2273. Ball lock pilot pin, with parabolic tip, heavy duty

d ₂ / (Order No)	d ₅	P	l ₁ / (Order No)	l / (Order Code character)	63 (C)	71 (D)	80 (E)	90 (F)	100 (G)	110 (H)	125 (J)
10 / (2)	10	5,9-9,9	19 (2)		●	●	●	●	●	●	●
13 / (3)	12	9,9-12,9	19 (2)		●	●	●	●	●	●	●
16 / (4)	12	12,9-15,9	25 (3)		●	●	●	●	●	●	●
20 / (5)	12	15,9-19,9	25 (3)		●	●	●	●	●	●	●
25 / (6)	12	19,9-24,9	25 (3)		●	●	●	●	●	●	●
32 / (7)	12	24,9-31,9	25 (3)			●	●	●	●	●	●
40 / (9)	12	31,9-39,9	30 (4)				●	●	●	●	●

Material:

HSS
Hardness 62 ± 2 HRC

Execution:

Shaft and pilot pin fine ground.
Special dimensions on request.

Note:

The 2 mm length provides full guidance before the blanking punch contacts the sheet metal.

Length of parabolic tip N:

= 8 mm where P ≤ 10 mm
= 12 mm where P 10,1 mm - 15 mm
= 15 mm where P > 15 mm

Ordering-code (example):

2 2 7 3 . 4 G 3 . 1 4 0 0

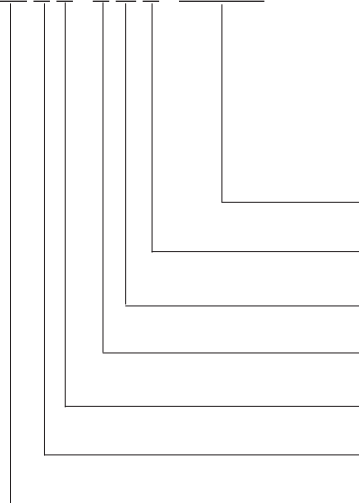

Format: Round

P = Ø 14,0 mm

Punch cutting length: l₁
25 mm

Length: l

100 mm

Diameter: d₂

16 mm

Type:

heavy

Version:

Pilot pin with parabolic tip

Punch:

without ejector pin

= 1400

Order No

= (3)

Order code character

= (G)

Order No

= (4)

Order No

= (3)

Order No

= (7)

= 22



Punches BOLT LOCK

Punches and retainers BOLT LOCK

The development of the BOLT LOCK system is a logical continuation of today's quick-release systems for punches beyond a shaft diameter of 40 mm.

Since the punches are available for any geometries, the compact system can be used for a variety of applications.

An example of this is the use of punches to cut sheet metal parts, which are not manufactured as individual parts, but rather mainly as multiple parts for economic reasons. Large perforations in structured parts of the car body can be manufactured without a problem using the system.

In the area of follow-on composites, the system can also be used to cut the grating or remove the pc board.

The system makes a valuable contribution to the further standardisation of tools and connected advantages in regard to time, costs and quality.

- Designed as a replacement for today's serially produced parts previously manufactured individually.
- Punches available in standard shapes and customer-specific special shapes according to data record.
- High quality due to automated serial production.
- Cost savings in design due to CAD standard parts library. Data in the currently common data formats can be called worldwide directly through fibro.partcommunity.com and is thus always up-to-date free of cost.
- Low spatial requirement as conventional system and therefore also an option for saving operations.
- Geometrical changes of the cutting contour do not affect the retaining plate, thus permitting cost savings in case of changes.
- Low mounting effort in tool maintenance, quick-release system.
- Punches are provided with extraction thread in the standard version. Lateral borehole in the case of cutting form width $W < 20$ mm.

Ordering example Punch BOLT LOCK

Note: See table for standard dimensions
Special dimensions to order

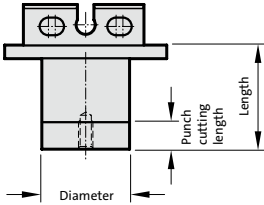

2 2 4 7 . 2 3 E 2 . 1 0 0 0 0 . 0 3 0 0 0 Z

Punch
22 without ejector pin

Execution:	Order No
○ blank	= 0**
⊙ round	= 1*
□ square	= 2*
▭ rectangular	= 3
◌ slot	= 4
◌ rectangle with radiused corners	= 5

*only for size (a x b): 01, 04, 05

**only available as CAD download

Note:

Special forms available upon customer's request.
Use blank 2207. for CAD data, see
fibro.partcommunity.com.

Punch cutting
length: l_1
20 = 2

Length: l
77 = E

Shape: slot
Length P = 100 mm

Shape: slot
Width W = 30 mm

optional
with retaining plate-
BOLT LOCK = Z

Size (a ₁ x b ₁)	Order No
01 (80 x 55)	= 1
02 (100 x 40)	= 2
03 (160 x 40)	= 3
04 (120 x 80)	= 4
05 (160 x 120)	= 5
06 (240 x 45)	= 6

Typ: BOLT LOCK = 7

Material HWS (1.2379) = 2
other materials and coatings available
upon request

Ordering example:

2 2 4 7 . 2 3 E 2 . 1 0 0 0 0 . 0 3 0 0 0 Z

optional: with retaining plate BOLT LOCK (Z)

- Shape: slot, Width W = 30 mm (03000)
- Shape: slot, Length P = 100 mm (10000)
- Punch cutting length: l_1 = 20 mm (2)
- Length: l = 77 mm (E)
- Size 03 (a₁ x b₁ = 160 x 40 mm) (3)
- Material: HWS (1.2379) = (2)
- Typ = BOLT LOCK (7)
- Execution: slot (4)
- Punch: without ejector pin (22)

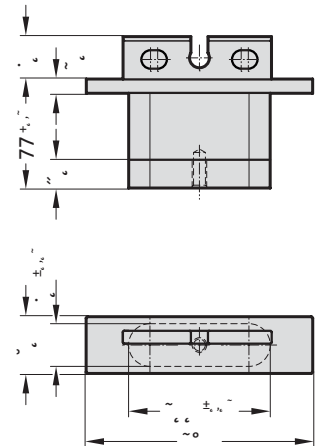

Special designs

Punch BOLT LOCK

BOLT LOCK punches can be designed with individual cutting contours.
 For this purpose, blanks are available as starting models at the fibro.partcommunity.com download portal.
 In this starting model, the corresponding cutting contour can be imported using the CAD system after download and preferably sent to FIBRO in STEP format.
 Six sizes are available at the download portal.
 During selection, the maximum dimensions X, Y of the cutting form apply as a limit.

Example:

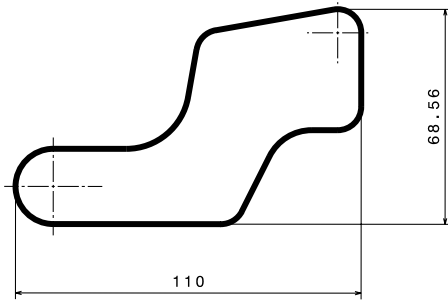

customer-specific cutting contour - max. dimensions of 110 x 69 mm



Selection of punch BOLT LOCK, blank according to the max. dimensions of the cutting form
 Size 04 (A1 x B1 : 120 x 80 mm)

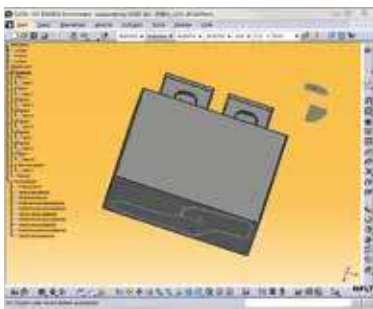

Download of model in desired CAD format (e.g.: STEP, CATIA, etc.)

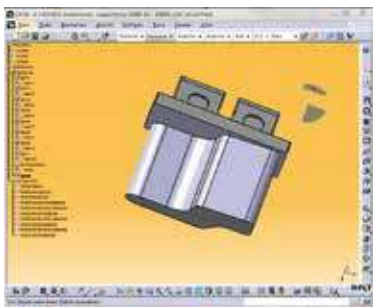

Incorporation of the cutting contour into the punch BOLT LOCK blank model.
 Send the data to FIBRO in STEP format.

Punch BOLT LOCK, blank

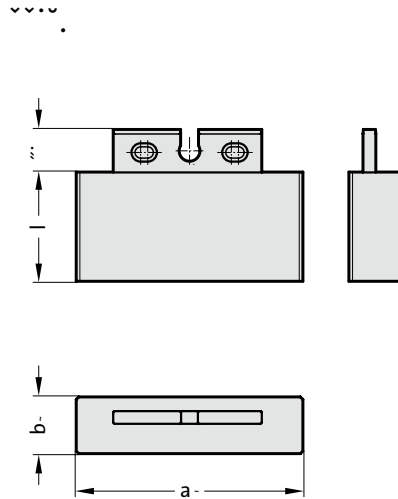

2207. Punch BOLT LOCK, blank

Size / (Order No)	a ₁	b ₁	l / (Order Code character)
01 / (1)	80	55	77 / (E)
02 / (2)	100	40	77 / (E)
03 / (3)	160	40	77 / (E)
04 / (4)	120	80	77 / (E)
05 / (5)	160	120	77 / (E)
06 / (6)	240	45	77 / (E)

Material:

HWS (1.2379)
Hardness 60 +2 HRC

Other materials upon request.

Description of FIBRO materials for tool and die components see at the beginning of Chapter E.

Note:

BOLT LOCK punches, blank, cannot be ordered. They are used only for customer-specific cutting contours/special designs.



Punch BOLT LOCK, round

Mounting example

2217.

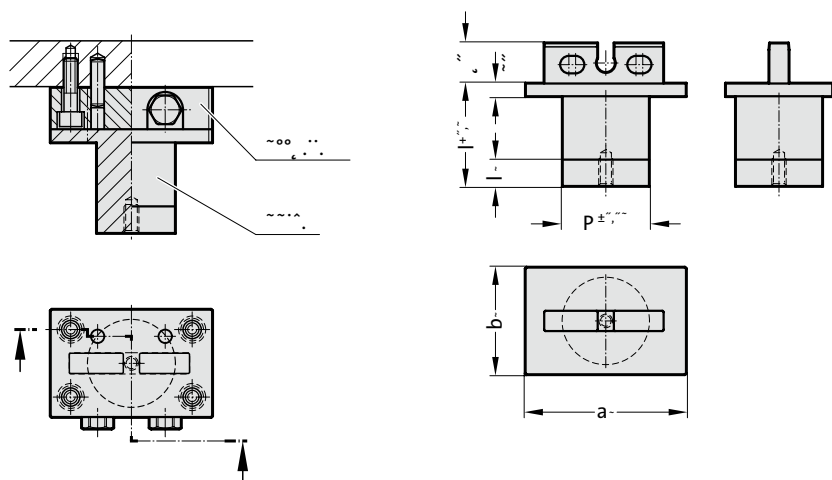

2217. Punch BOLT LOCK, round

Size / (Order No)	a ₁	b ₁	P _{min}	P _{max}	l ₁ / (Order No)	l / (Order Code character)
01 / (1)	80	55	35	54.9	20 / (2)	77 / (E)
04 / (4)	120	80	50	79.9	20 / (2)	77 / (E)
05 / (5)	160	120	75	119.9	20 / (2)	77 / (E)

Ordering-code (example):

2217.21E2.05000

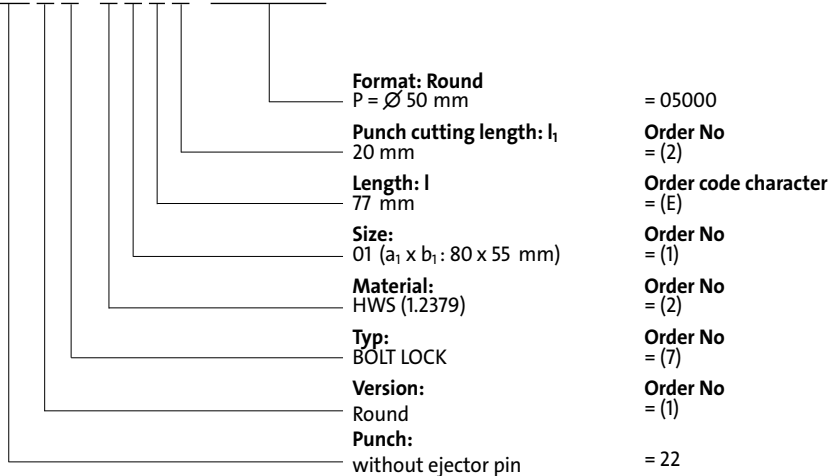

Material:

HWS (1.2379)
Hardness 60 +2 HRC

Other materials upon request.

Description of FIBRO materials for tool and die components see at the beginning of Chapter E.

Execution:

BOLT LOCK punches, round, are provided with an extraction thread (M10).

Note:

Order number for punch BOLT LOCK, round with retaining plate BOLT LOCK, including screws and pins:

2217.2□ E2.□□□□□□

Punch BOLT LOCK, square



2227.

Mounting example

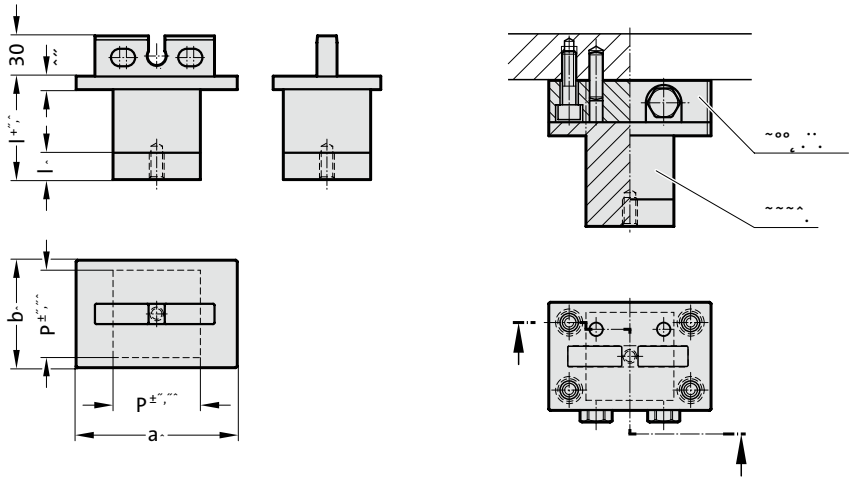

2227. Punch BOLT LOCK, square

Size / (Order No)	a ₁	b ₁	P _{min}	P _{max}	l ₁ / (Order No)	l / (Order Code character)
01 / (1)	80	55	35	54.9	20 / (2)	77 / (E)
04 / (4)	120	80	50	79.9	20 / (2)	77 / (E)
05 / (5)	160	120	75	119.9	20 / (2)	77 / (E)

Material:

HWS (1.2379)
Hardness 60 +2 HRC

Other materials upon request.

Description of FIBRO materials for tool and die components see at the beginning of Chapter E.

Execution:

BOLT LOCK punches, square, are provided with an extraction thread (M10).

Note:

Order number for punch BOLT LOCK, square with retaining plate BOLT LOCK, including screws and pins:
2227.2□ E2.□□□□□Z

Ordering-code (example):

2227.21E2.04050

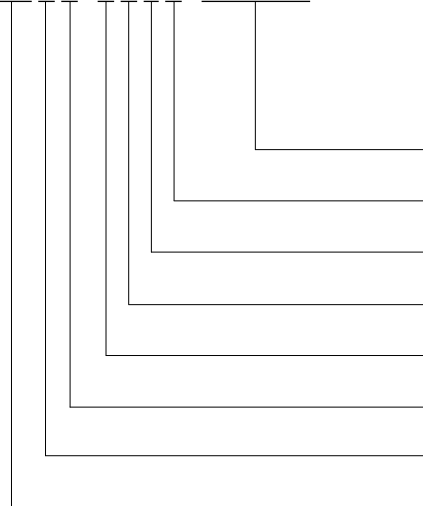

Format: Square	= 04050
P = 40,5 mm	
Punch cutting length: l ₁	Order No
20 mm	= (2)
Length: l	Order code character
77 mm	= (E)
Size:	Order No
01 (a ₁ x b ₁ : 80 x 55 mm)	= (1)
Material:	Order No
HWS (1.2379)	= (2)
Typ:	Order No
BOLT LOCK	= (7)
Version:	Order No
Square	= (2)
Punch:	
without ejector pin	= 22



Punch BOLT LOCK, rectangular

Mounting example

2237.

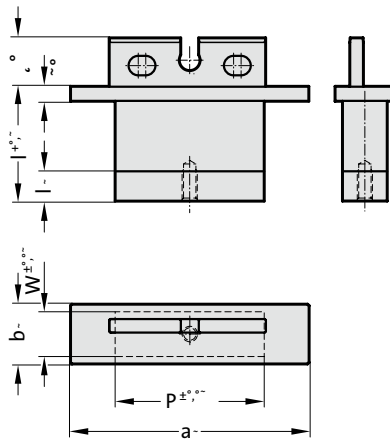
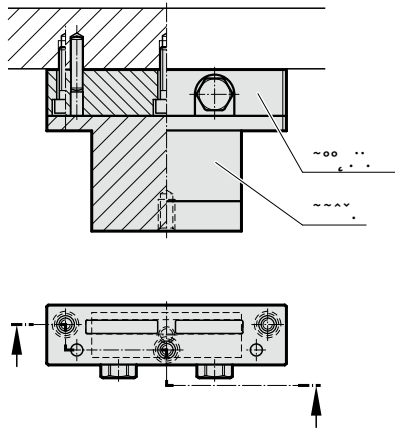

2237. Punch BOLT LOCK, rectangular

Size / (Order No)	a ₁	b ₁	P _{min}	P _{max}	W _{min}	W _{max}	I ₁ / (Order No)	I / (Order Code character)
01 / (1)	80	55	55	79.9	10	54.9	20 / (2)	77 / (E)
02 / (2)	100	40	40	99.9	10	39.9	20 / (2)	77 / (E)
03 / (3)	160	40	40	159.9	10	39.9	20 / (2)	77 / (E)
04 / (4)	120	80	80	119.9	10	79.9	20 / (2)	77 / (E)
05 / (5)	160	120	120	159.9	10	119.9	20 / (2)	77 / (E)
06 / (6)	240	45	45	239.9	10	44.9	20 / (2)	77 / (E)

Ordering-code (example):

2237.21E2.07050.04550

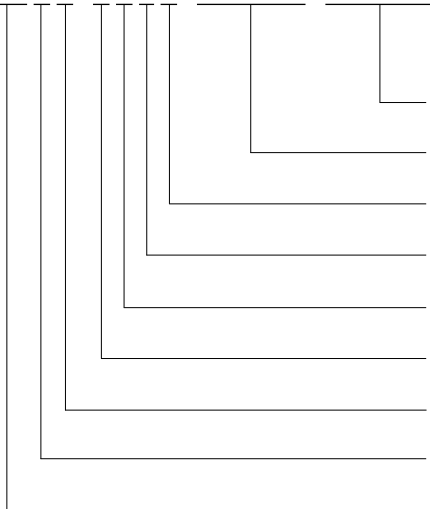

- Format: Rectangular, width W**
W = 45,5 mm = 04550
- Format: Rectangular, length P**
P = 70,5 mm = 07050
- Punch cutting length: I₁**
20 mm = (2)
- Length: I**
77 mm = (E)
- Size:**
01 (a₁ x b₁: 80 x 55 mm) = (1)
- Material:**
HWS (1.2379) = (2)
- Typ:**
BOLT LOCK = (7)
- Version:**
Rectangular = (3)
- Punch:**
without ejector pin = 22

Material:

HWS (1.2379)
Hardness 60 +2 HRC

Other materials upon request.

Description of FIBRO materials for tool and die components see at the beginning of Chapter E.

Execution:

BOLT LOCK punches, rectangle, are provided with an extraction thread (M10). For cutting form width W < 20 mm, the punch is provided with a transverse borehole (∅10 mm).

Note:

Order number for punch BOLT LOCK, rectangle with retaining plate BOLT LOCK, including screws and pins:
2237.20 E2.□□□□□□.□□□□□□

Punch BOLT LOCK, slot



2247.

Mounting example

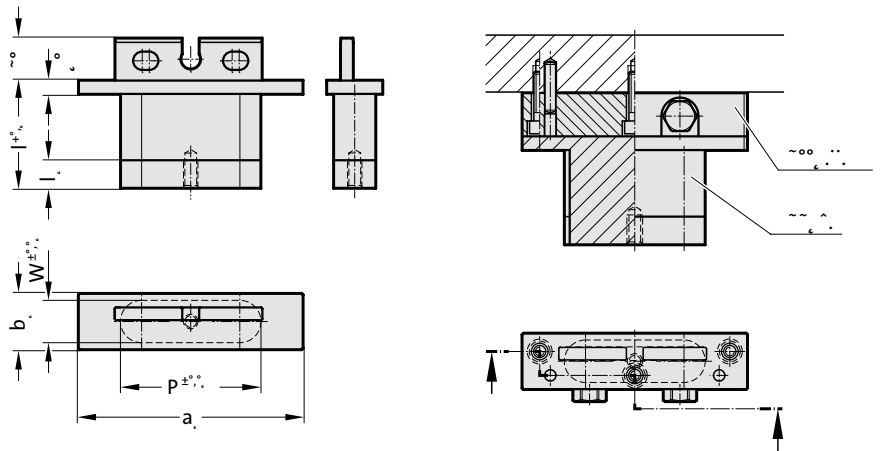

2247. Punch BOLT LOCK, slot

Size / (Order No)	a ₁	b ₁	P _{min}	P _{max}	W _{min}	W _{max}	l ₁ / (Order No)	l / (Order Code character)
1 / (1)	80	55	55	79.9	10	54.9	20 / (2)	77 / (E)
2 / (2)	100	40	40	99.9	10	39.9	20 / (2)	77 / (E)
3 / (3)	160	40	40	159.9	10	39.9	20 / (2)	77 / (E)
4 / (4)	120	80	80	119.9	10	79.9	20 / (2)	77 / (E)
5 / (5)	160	120	120	159.9	10	119.9	20 / (2)	77 / (E)
6 / (6)	240	45	45	239.9	10	44.9	20 / (2)	77 / (E)

Material:

HWS (1.2379)
Hardness 60 +2 HRC

Other materials upon request.

Description of FIBRO materials for tool and die components see at the beginning of Chapter E.

Execution:

BOLT LOCK punches with an slot are provided with an extraction thread (M10).
For cutting form width $W < 20$ mm, the punch is provided with a transverse bore ($\varnothing 10$ mm).

Note:

Order number for punch BOLT LOCK, slot with retaining plate BOLT LOCK, including screws and pins:

2247.2□ E2.□□□□□□.□□□□□□□

Ordering-code (example):

2247.21E2.07050.04550

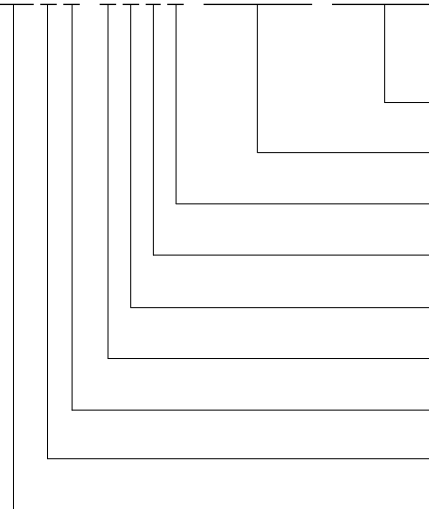

Format: Slot, width W
W = 45,5 mm = 04550

Format: Slot, length P
P = 70,5 mm = 07050

Punch cutting length: l₁
20 mm = (2)

Length: l
77 mm = (E)

Size:
01 (a₁ x b₁: 80 x 55 mm) = (1)

Material:
HWS (1.2379) = (2)

Typ:
BOLT LOCK = (7)

Version:
Slot = (4)

Punch:
without ejector pin = 22



Punch BOLT LOCK, rectangle with radiused corners

Mounting example

2257.

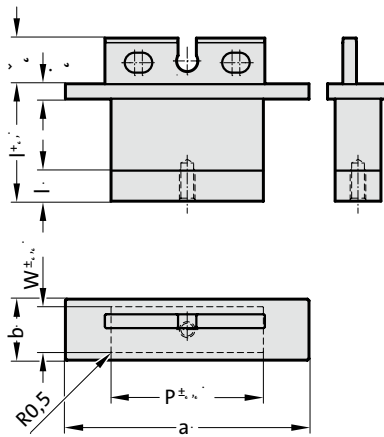
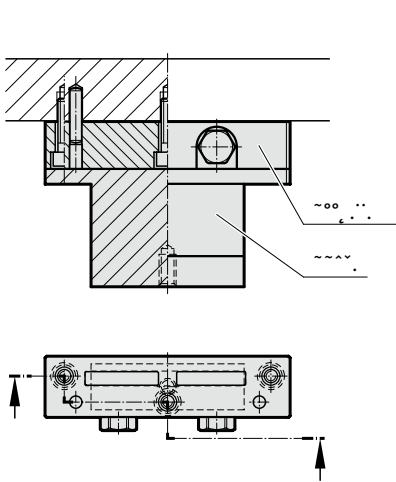

2257. Punch BOLT LOCK, rectangle with radiused corners

Size / (Order No)	a ₁	b ₁	P _{min}	P _{max}	W _{min}	W _{max}	I ₁ / (Order No)	I / (Order Code character)
01 / (1)	80	55	55	79.9	10	54.9	20 / (E)	77 / (E)
02 / (2)	100	40	40	99.9	10	39.9	20 / (E)	77 / (E)
03 / (3)	160	40	40	159.9	10	39.9	20 / (E)	77 / (E)
04 / (4)	120	80	80	119.9	10	79.9	20 / (E)	77 / (E)
05 / (5)	160	120	120	159.9	10	119.9	20 / (E)	77 / (E)
06 / (6)	240	45	45	239.9	10	44.9	20 / (E)	77 / (E)

Ordering-code (example):

2257.21E2.07050.04550

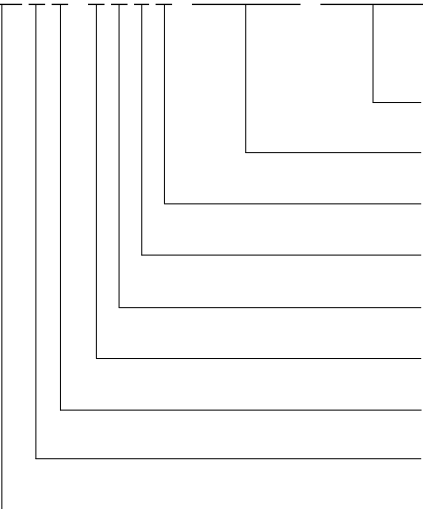

Format: Rectangle with radiused corners, width W W = 45,5 mm	= 04550
Format: Rectangle with radiused corners, length P P = 70,5 mm	= 07050
Punch cutting length: I₁ 20 mm	Order No = (2)
Length: I 77 mm	Order code character = (E)
Size: 01 (a ₁ x b ₁ : 80 x 55 mm)	Order No = (1)
Material: HWS (1.2379)	Order No = (2)
Typ: BOLT LOCK	Order No = (7)
Version: Rectangle with radiused corners	Order No = (5)
Punch: without ejector pin	= 22

Material:

HWS (1.2379)
Hardness 60 +2 HRC

Other materials upon request.

Description of FIBRO materials for tool and die components see at the beginning of Chapter E.

Execution:

BOLT LOCK punches, rectangle with radius, are provided with an extraction thread (M10). For cutting form width W < 20 mm, the punch is provided with a transverse bore (∅ 10 mm).

Note:

Order number for punch BOLT LOCK, rectangle with radius and retaining plate BOLT LOCK, including screws and pins:
2257.2□ E2.□□□□□□.□□□□□□Z



Punches ISO 8020



Ordering example Punches ISO 8020

Note: See table for standard dimensions
Special dimensions to order

Punch:
22 without ejector pin
27 with ejector pin

Version:

Version	Order No
blank	= 0
round	= 1
square	= 2
rectangular	= 3
slot	= 4
rectangle with radiused corners	= 5
pilot pin with tapered tip	= 6
pilot pin parabolic tip	= 7
special shapes	= 9

Type:

Type	Order No
ISO	= 1

Punch cutting length: l_1

Punch cutting length: l_1	Order No
8	= 1
10	= 2
13	= 3
19	= 4
25	= 5
30	= 6
special	= X

Diameter: d_1

Diameter: d_1	Order No
3	= 1
4	= 2
5	= 3
6	= 4
8	= 5
10	= 6
13	= 7
16	= 8
20	= 9
25	= 10
32	= 11

Length: l

Length: l	Order Code character
50	= A
56	= B
63	= C
71	= D
80	= E
90	= F
100	= G
110	= H
120	= J
125	= K
140	= L
150	= M
200	= N
special	= X

Format: Slot length P = 6,5 mm

Format: Slot width W = 4,5 mm

Angle:

Angle	Order Code character
0°	= A
90°	= B
180°	= C
270°	= D
special	= X

Ordering Code Example: 2 2 4 1 . 7 G 4 . 0 6 5 0 . 0 4 5 0 A

Ordering Code (Example):

2 2 4 1 . 7 G 4 . 0 6 5 0 . 0 4 5 0 A

- 22: Punch: without ejector pin
- 4: Version: Slot
- 1: Type = ISO
- 7: Diameter: $d_1 = 13$ mm
- G: Length: $l = 100$ mm
- 4: Punch cutting length: $l_1 = 19$ mm
- 0650: Format: Slot, length P = 6,5 mm
- 0450: Format: Slot, width W = 4,5 mm
- A: Angle = 0°

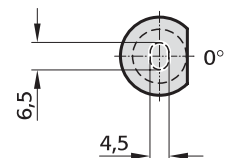
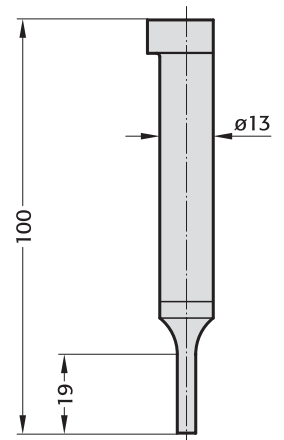

Punch, blank, ISO 8020

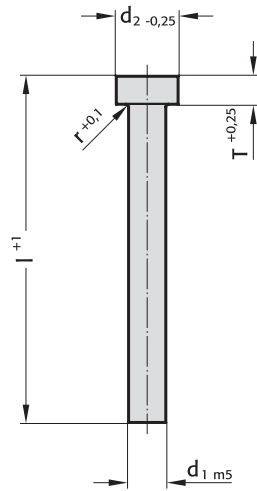

2201. Punch, blank, ISO 8020

d ₁ / (Order No)	d ₂	r	T	l / (Order Code character)	71 (D)	80 (E)	90 (F)	100 (G)	120 (J)	150 (M)	200 (N)
3 / (1)	5	0.25	3		●	●	●	●	●		
4 / (2)	6	0.25	3		●	●	●	●	●		
5 / (3)	8	0.3	5		●	●	●	●	●		
6 / (4)	9	0.3	5		●	●	●	●	●		
8 / (5)	11	0.3	5		●	●	●	●	●		
10 / (6)	13	0.3	5		●	●	●	●	●	●	
13 / (7)	16	0.4	5		●	●	●	●	●	●	
16 / (8)	19	0.4	5		●	●	●	●	●	●	●
20 / (9)	23	0.4	5		●	●	●	●	●	●	●
25 / (10)	28	0.4	5		●	●	●	●	●	●	●
32 / (11)	35	0.4	5		●	●	●	●	●	●	●

Ordering code (example):

2201.7G.ASP

complete for material ASP

Length: l
100 mm
Diameter: d₁
13 mm
Type:
ISO
Version:
blank
Punch:
without ejector pin

Order Code character
= (G)
Order No
= (7)
Order No
= (1)
Order No
= (0)
= 22

Material:

HSS
Hardness:
Shaft 64 ± 2 HRC
Head 52 ± 5 HRC

ASP 23 - ASP 2023
upon request
Description of FIBRO materials for tool and die components see at the beginning of Chapter E.

Execution:

Punch head hot upset-forged. Shoulder and shaft fine ground.
Special dimensions on request.

Punch, stepped, round, ISO 8020

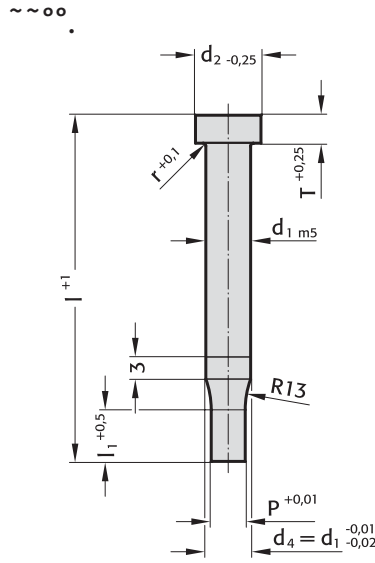

2211. Punch, stepped, round, ISO 8020

d ₁ / (Order No)	d ₂	P	l ₁ / (Order No)	r	T	l / (Order Code character)	71 (D)	80 (E)	90 (F)	100 (G)	120 (J)
3 / (1)	5	0,8-2,9	8 (1) 10 (2)	0,25	3		●	●	●	●	●
4 / (2)	6	1,0-3,9	8 (1) 13 (3)	0,25	3		●	●	●	●	●
5 / (3)	8	1,5-4,9	13 (3) 19 (4)	0,3	5		●	●	●	●	●
6 / (4)	9	1,6-5,9	13 (3) 19 (4)	0,3	5		●	●	●	●	●
8 / (5)	11	2,5-7,9	19 (4) 25 (5)	0,3	5		●	●	●	●	●
10 / (6)	13	4,0-9,9	19 (4) 25 (5)	0,3	5		●	●	●	●	●
13 / (7)	16	5,0-12,9	19 (4) 25 (5)	0,4	5		●	●	●	●	●
16 / (8)	19	8,0-15,9	19 (4) 25 (5)	0,4	5		●	●	●	●	●
20 / (9)	23	12,0-19,9	19 (4) 25 (5)	0,4	5		●	●	●	●	●
25 / (10)	28	16,5-24,9	19 (4) 25 (5)	0,4	5		●	●	●	●	●
32 / (11)	35	20,0-31,9	25 (5) 30 (6)	0,4	5		●	●	●	●	●

Material:

HSS
 Hardness:
 Shaft 64 ± 2 HRC
 Head 52 ± 5 HRC

ASP 23 - ASP 2023
 upon request

Description of FIBRO materials for tool and die components see at the beginning of Chapter E.

Execution:

Punch head hot upset-forged. Shoulder, shaft and punch diameter fine ground.
 Special dimensions on request.

Ordering-code (example):

2 2 1 1 . 7 G 4 . 0 7 0 0

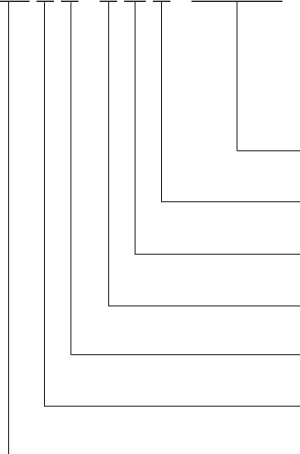

Format: Round

P = Ø 7,0 mm

Punch cutting length: l₁

19 mm

Length: l

100 mm

Diameter: d₁

13 mm

Type:

ISO

Version:

Round

Punch:

without ejector pin

= 0700

Order No

= (4)

Order code character

= (G)

Order No

= (7)

Order No

= (1)

Order No

= (1)

= 22



Punch, stepped, square, ISO 8020

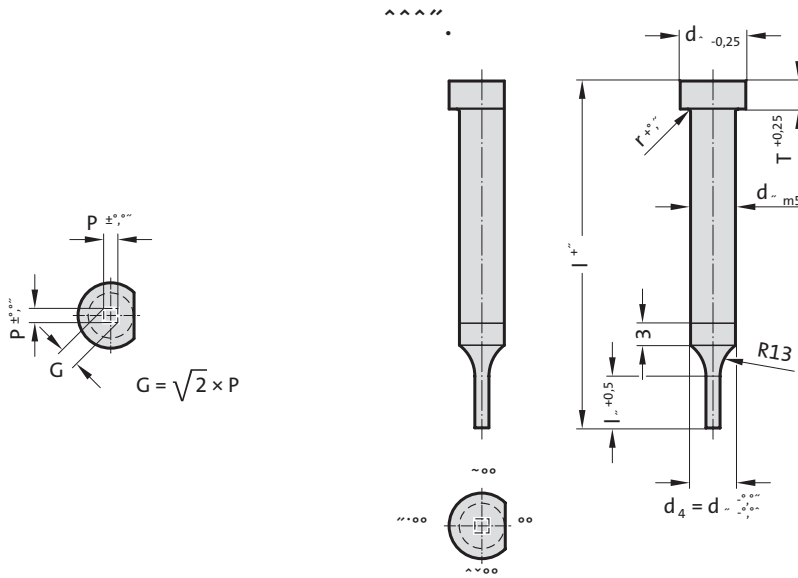

2221. Punch, stepped, square, ISO 8020

d ₁ / (Order No)	d ₂	P _{min}	G _{max}	l ₁ / (Order No)	r	T	l / (Order Code character)	71 (D)	80 (E)	90 (F)	100 (G)	120 (J)
3 / (1)	5	0.5	2.9	8 (1) 10 (2)	0.25	3		●	●	●	●	●
4 / (2)	6	0.8	3.9	8 (1) 13 (3)	0.25	3		●	●	●	●	●
5 / (3)	8	1	4.9	13 (3) 19 (4)	0.3	5		●	●	●	●	●
6 / (4)	9	1.6	5.9	13 (3) 19 (4)	0.3	5		●	●	●	●	●
8 / (5)	11	2	7.9	19 (4) 25 (5)	0.3	5		●	●	●	●	●
10 / (6)	13	3.5	9.9	19 (4) 25 (5)	0.3	5		●	●	●	●	●
13 / (7)	16	4.5	12.9	19 (4) 25 (5)	0.4	5		●	●	●	●	●
16 / (8)	19	6	15.9	19 (4) 25 (5)	0.4	5		●	●	●	●	●
20 / (9)	23	8	19.9	19 (4) 25 (5)	0.4	5		●	●	●	●	●
25 / (10)	28	10	24.9	19 (4) 25 (5)	0.4	5		●	●	●	●	●
32 / (11)	35	10	31.9	25 (5) 30 (6)	0.4	5		●	●	●	●	●

Ordering-code (example):

22 21. 10 E 5. 15 00 B

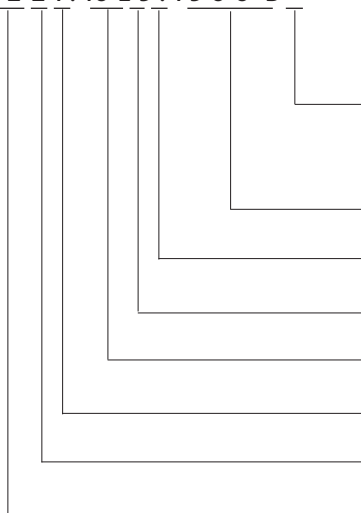

Angle:
90°

Format: Square, length P

P = 15,0 mm

Punch cutting length: l₁

25 mm

Length: l

80 mm

Diameter: d₁

25 mm

Type:

ISO

Version:

Square

Punch:

without ejector pin

Order code character
= (B)

= 1500

Order No

= (5)

Order code character

= (E)

Order No

= (10)

Order No

= (1)

Order No

= (2)

= 22

Material:

HSS

Hardness:

Shaft 64 ± 2 HRC

Head 52 ± 5 HRC

ASP 23 - ASP 2023

upon request

Description of FIBRO materials for tool and die components see at the beginning of Chapter E.

Execution:

Punch head hot upset-forged. Shoulder, shaft and punch shape fine ground.

The anti-rotation surface parallel to P = 0° as standard.

Special dimensions on request.

Punch, stepped, rectangular, ISO 8020



2231.

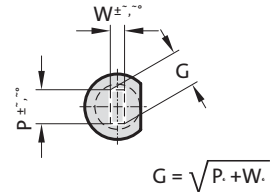
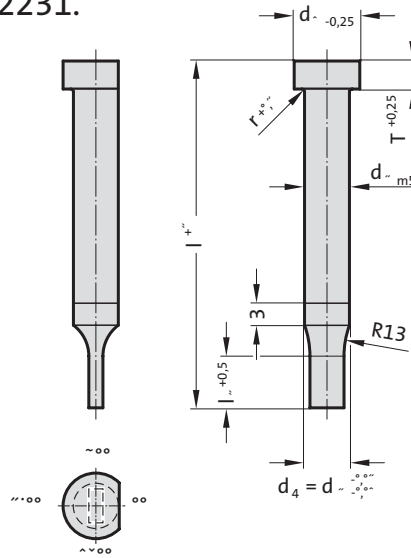

2231. Punch, stepped, rectangular, ISO 8020

d ₁ / (Order No)	d ₂	W _{min}	G _{max}	l ₁ / (Order No)	r	T	l / (Order Code character)	71 (D)	80 (E)	90 (F)	100 (G)	120 (J)
3 / (1)	5	0.5	2.9	8 (1) 10 (2)	0.25	3		●	●	●	●	●
4 / (2)	6	0.8	3.9	8 (1) 13 (3)	0.25	3		●	●	●	●	●
5 / (3)	8	1	4.9	13 (3) 19 (4)	0.3	5		●	●	●	●	●
6 / (4)	9	1.6	5.9	13 (3) 19 (4)	0.3	5		●	●	●	●	●
8 / (5)	11	2	7.9	19 (4) 25 (5)	0.3	5		●	●	●	●	●
10 / (6)	13	3.5	9.9	19 (4) 25 (5)	0.3	5		●	●	●	●	●
13 / (7)	16	4.5	12.9	19 (4) 25 (5)	0.4	5		●	●	●	●	●
16 / (8)	19	6	15.9	19 (4) 25 (5)	0.4	5		●	●	●	●	●
20 / (9)	23	8	19.9	19 (4) 25 (5)	0.4	5		●	●	●	●	●
25 / (10)	28	10	24.9	19 (4) 25 (5)	0.4	5		●	●	●	●	●
32 / (11)	35	10	31.9	25 (5) 30 (6)	0.4	5		●	●	●	●	●

Material:

HSS
 Hardness:
 Shaft 64 ± 2 HRC
 Head 52 ± 5 HRC

ASP 23 - ASP 2023
 upon request

Description of FIBRO materials for tool and die components see at the beginning of Chapter E.

Execution:

Punch head hot upset-forged. Shoulder, shaft and punch shape fine ground.
 The anti-rotation surface parallel to P = 0° as standard.
 Special dimensions on request.

Ordering-code (example):

2231.9F4.1500.1150B

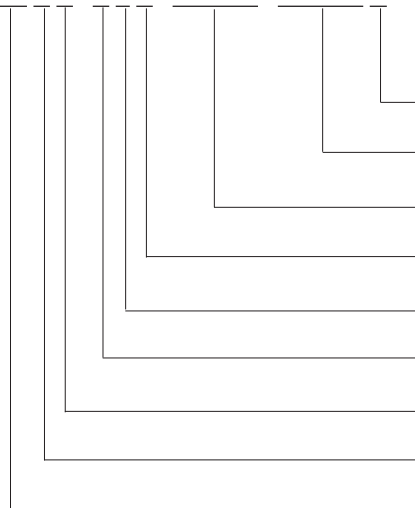

- Angle:** 90° **Order code character** = (B)
- Format: Rectangular, width W** W = 11,5 mm = 1150
- Format: Rectangular, length P** P = 15,0 mm = 1500
- Punch cutting length: l₁** 19 mm **Order No** = (4)
- Length: l** 90 mm **Order code character** = (F)
- Diameter: d₁** 20 mm **Order No** = (9)
- Type:** ISO **Order No** = (1)
- Version:** Rectangular **Order No** = (3)
- Punch:** without ejector pin = 22



Punch, stepped, slot, ISO 8020

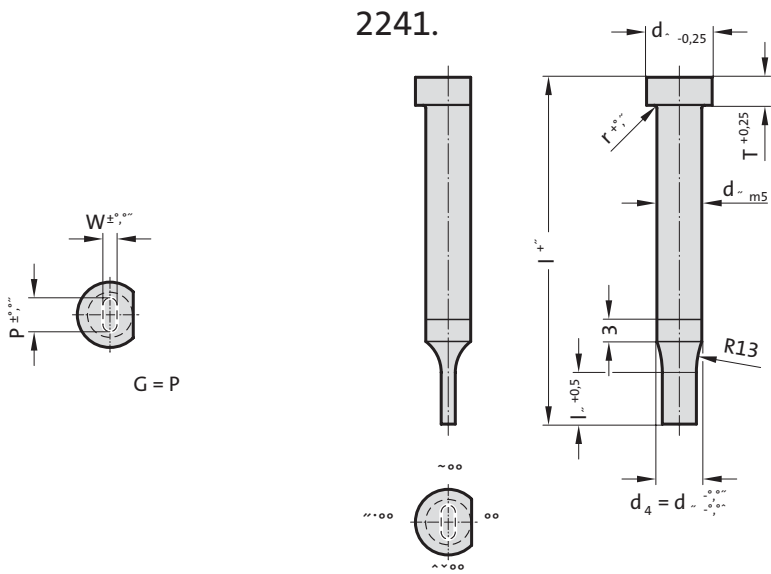

2241. Punch, stepped, slot, ISO 8020

d ₁ / (Order No)	d ₂	W _{min}	G _{max}	l ₁ / (Order No)	r	T	l / (Order Code character)	71 (D)	80 (E)	90 (F)	100 (G)	120 (J)
3 / (1)	5	0.5	2.9	8 (1) 10 (2)	0.25	3		●	●	●	●	●
4 / (2)	6	0.8	3.9	8 (1) 13 (3)	0.25	3		●	●	●	●	●
5 / (3)	8	1	4.9	13 (3) 19 (4)	0.3	5		●	●	●	●	●
6 / (4)	9	1.6	5.9	13 (3) 19 (4)	0.3	5		●	●	●	●	●
8 / (5)	11	2	7.9	19 (4) 25 (5)	0.3	5		●	●	●	●	●
10 / (6)	13	3.5	9.9	19 (4) 25 (5)	0.3	5		●	●	●	●	●
13 / (7)	16	4.5	12.9	19 (4) 25 (5)	0.4	5		●	●	●	●	●
16 / (8)	19	6	15.9	19 (4) 25 (5)	0.4	5		●	●	●	●	●
20 / (9)	23	8	19.9	19 (4) 25 (5)	0.4	5		●	●	●	●	●
25 / (10)	28	10	24.9	19 (4) 25 (5)	0.4	5		●	●	●	●	●
32 / (11)	35	10	31.9	25 (5) 30 (6)	0.4	5		●	●	●	●	●

Ordering-code (example):

22 41.10 E 5.2020.1220 A

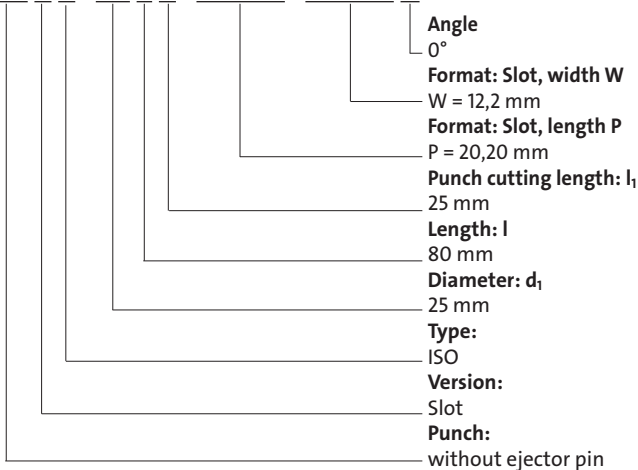

Order code character = (A)
= 1220
Order No = 2020
Order code character = (E)
Order No = (10)
Order No = (1)
Order No = (4)
= 22

Material:

HSS
Hardness:
Shaft 64 ± 2 HRC
Head 52 ± 5 HRC

ASP 23 - ASP 2023
upon request

Description of FIBRO materials for tool and die components see at the beginning of Chapter E.

Execution:

Punch head hot upset-forged. Shoulder, shaft and punch shape fine ground.
The anti-rotation surface parallel to P = 0° as standard.
Special dimensions on request.

Punch, stepped, rectangle with radiused corners, ISO 8020



2251.

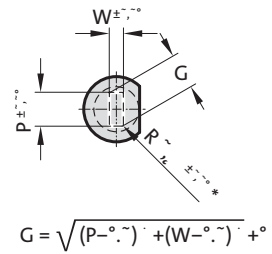
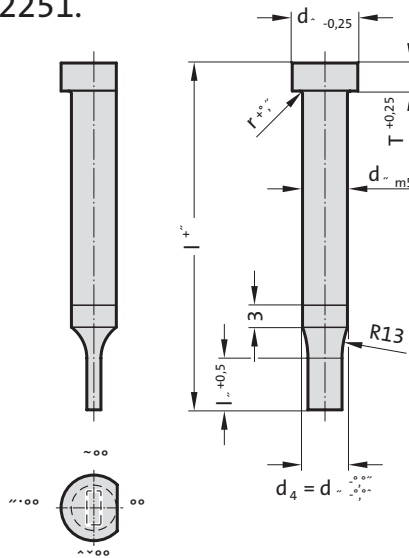

2251. Punch, stepped, rectangle with radiused corners, ISO 8020

d ₁ / (Order No)	d ₂	W _{min}	G _{max}	l ₁ / (Order No)	r	T	l / (Order Code character)	71 (D)	80 (E)	90 (F)	100 (G)	120 (J)
3 / (1)	5	0.5	2.9	8 (1) 10 (2)	0.25	3		●	●	●	●	●
4 / (2)	6	0.8	3.9	8 (1) 13 (3)	0.25	3		●	●	●	●	●
5 / (3)	8	1	4.9	13 (3) 19 (4)	0.3	5		●	●	●	●	●
6 / (4)	9	1.6	5.9	13 (3) 19 (4)	0.3	5		●	●	●	●	●
8 / (5)	11	2	7.9	19 (4) 25 (5)	0.3	5		●	●	●	●	●
10 / (6)	13	3.5	9.9	19 (4) 25 (5)	0.3	5		●	●	●	●	●
13 / (7)	16	4.5	12.9	19 (4) 25 (5)	0.4	5		●	●	●	●	●
16 / (8)	19	6	15.9	19 (4) 25 (5)	0.4	5		●	●	●	●	●
20 / (9)	23	8	19.9	19 (4) 25 (5)	0.4	5		●	●	●	●	●
25 / (10)	28	10	24.9	19 (4) 25 (5)	0.4	5		●	●	●	●	●
32 / (11)	35	10	31.9	25 (5) 30 (6)	0.4	5		●	●	●	●	●

Material:

HSS
 Hardness:
 Shaft 64 ± 2 HRC
 Head 52 ± 5 HRC

ASP 23 - ASP 2023
 upon request

Description of FIBRO materials for tool and die components see at the beginning of Chapter E.

Execution:

Punch head hot upset-forged. Shoulder, shaft and punch shape fine ground.

The anti-rotation surface parallel to P = 0° as standard.

Special dimensions on request.

* For other radius options, see standardised special shapes.

Ordering-code (example):

2251.9F4.1215.1100B

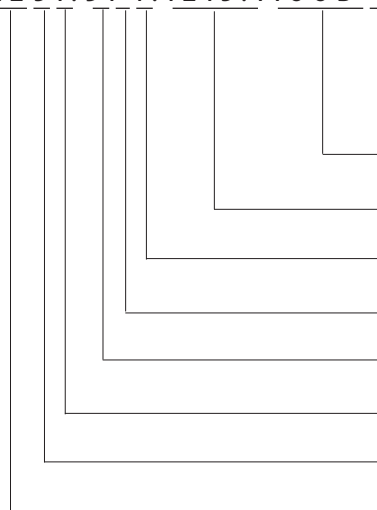

Angle: 90°
Format: Rectangle with radiused corners, width W
 W = 11,0 mm
Format: Rectangle with radiused corners, length P
 P = 12,15 mm
Punch cutting length: l₁
 19 mm
Length: l
 90 mm
Diameter: d₁
 20 mm
Type: ISO
Version: Rectangle with radiused corners
Punch: without ejector pin

Order code character = (B)
Order No = 1100
Order No = 1215
Order code character = (F)
Order No = (4)
Order code character = (9)
Order No = (1)
Order No = (5)
Order No = 22

Punch, blank, with ejector pin, ISO 8020



2701.

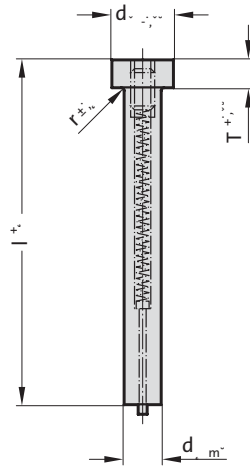

2701. Punch, blank, with ejector pin, ISO 8020

d ₁ / (Order No)	d ₂	r	T	l / (Order Code character)	71 (D)	80 (E)	90 (F)	100 (G)	120 (J)
5 / (3)	8	0.3	5		●	●	●	●	●
6 / (4)	9	0.3	5		●	●	●	●	●
8 / (5)	11	0.3	5		●	●	●	●	●
10 / (6)	13	0.3	5		●	●	●	●	●
13 / (7)	16	0.4	5		●	●	●	●	●
16 / (8)	19	0.4	5		●	●	●	●	●
20 / (9)	23	0.4	5		●	●	●	●	●
25 / (10)	28	0.4	5		●	●	●	●	●
32 / (11)	35	0.4	5		●	●	●	●	●

Ordering-code (example):

27 01 . 11 G

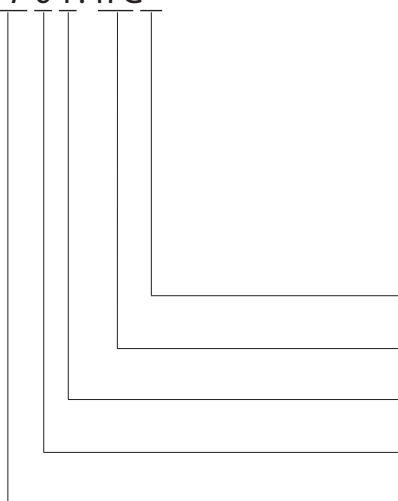

Length: l
100 mm
Diameter: d₁
32 mm
Type:
ISO
Version:
blank
Punch:
with ejector pin

Order code character
= (G)
Order No
= (11)
Order No
= (1)
Order No
= (0)
= 27

Material:

HSS
Hardness:
Shaft 64 ± 2 HRC
Head 52 ± 5 HRC

Execution:

Punch head hot upset-forged. Shoulder and shaft fine ground.
Special dimensions on request.

Punch, stepped, round, with ejector pin, ISO 8020



2711.

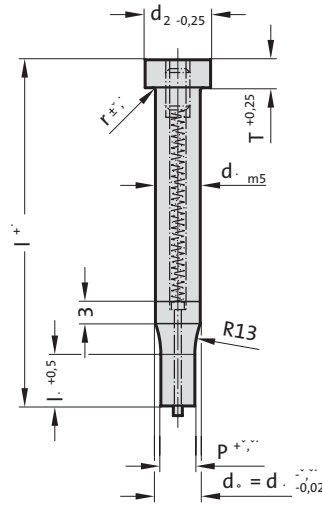

2711. Punch, stepped, round, with ejector pin, ISO 8020

d ₁ / (Order No)	d ₂	P	l ₁ / (Order No)	r	T	l / (Order Code character)	71 (D)	80 (E)	90 (F)	100 (G)	120 (J)
5 / (3)	8	1,6-4,9	13 (3) 19 (4)	0,3	5		●	●	●	●	●
6 / (4)	9	2,5-5,9	13 (3) 19 (4)	0,3	5		●	●	●	●	●
8 / (5)	11	2,5-7,9	19 (4) 25 (5)	0,3	5		●	●	●	●	●
10 / (6)	13	4,0-9,9	19 (4) 25 (5)	0,3	5		●	●	●	●	●
13 / (7)	16	5,0-12,9	19 (4) 25 (5)	0,4	5		●	●	●	●	●
16 / (8)	19	8,0-15,9	19 (4) 25 (5)	0,4	5		●	●	●	●	●
20 / (9)	23	12,0-19,9	19 (4) 25 (5)	0,4	5		●	●	●	●	●
25 / (10)	28	16,5-24,9	19 (4) 25 (5)	0,4	5		●	●	●	●	●
32 / (11)	35	20,0-31,9	25 (5) 30 (6)	0,4	5		●	●	●	●	●

Material:

HSS
 Hardness:
 Shaft 64 ± 2 HRC
 Head 52 ± 5 HRC

Execution:

Punch head hot upset-forged. Shoulder, shaft and punch diameter fine ground.
 Special dimensions on request.

Ordering-code (example):

2711.7G4.0700

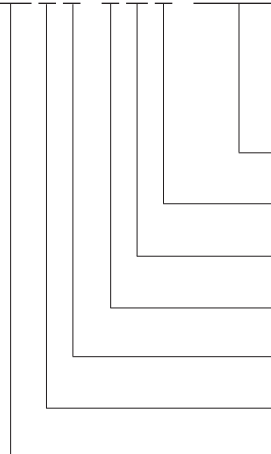

Format: Round
 P = Ø 7,0 mm
Punch cutting length: l₁
 19 mm
Length: l
 100 mm
Diameter: d₁
 13 mm
Type:
 ISO
Version:
 Round
Punch:
 with ejector pin

= 0700
Order No
 = (4)
Order code character
 = (G)
Order No
 = (7)
Order No
 = (1)
Order No
 = (1)
 = 27



Punch, stepped, square, with ejector pin, ISO 8020

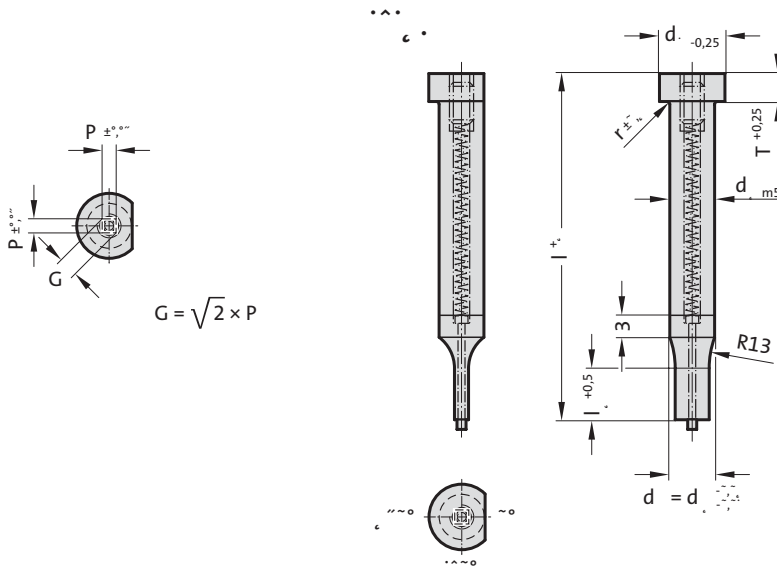

2721. Punch, stepped, square, with ejector pin, ISO 8020

d ₁ / (Order No)	d ₂	P _{min}	G _{max}	l ₁ / (Order No)	r	T	l / (Order Code character)	71 (D)	80 (E)	90 (F)	100 (G)	120 (J)
5 / (3)	8	1.6	4.9	13 (3) 19 (4)	0.3	5		●	●	●	●	●
6 / (4)	9	2.5	5.9	13 (3) 19 (4)	0.3	5		●	●	●	●	●
8 / (5)	11	2.5	7.9	19 (4) 25 (5)	0.3	5		●	●	●	●	●
10 / (6)	13	4	9.9	19 (4) 25 (5)	0.3	5		●	●	●	●	●
13 / (7)	16	5	12.9	19 (4) 25 (5)	0.4	5		●	●	●	●	●
16 / (8)	19	8	15.9	19 (4) 25 (5)	0.4	5		●	●	●	●	●
20 / (9)	23	12	19.9	19 (4) 25 (5)	0.4	5		●	●	●	●	●
25 / (10)	28	16.5	24.9	19 (4) 25 (5)	0.4	5		●	●	●	●	●
32 / (11)	35	20	31.9	25 (5) 30 (6)	0.4	5		●	●	●	●	●

Ordering-code (example):

27 21. 10 D 5. 16 50 A

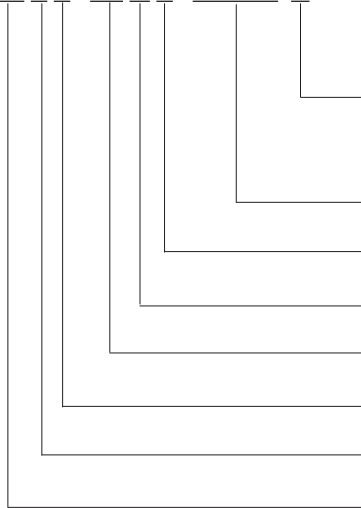

Angle:
0°

Format: Square, length P

P = 16,5 mm

Punch cutting length: l₁

25 mm

Length: l

71 mm

Diameter: d₁

25 mm

Type:

ISO

Version:

Square

Punch:

with ejector pin

Order code character
= (A)

= 1650

Order No

= (5)

Order code character

= (D)

Order No

= (10)

Order No

= (1)

Order No

= (2)

= 27

Material:

HSS

Hardness:

Shaft 64 ± 2 HRC

Head 52 ± 5 HRC

Execution:

Punch head hot upset-forged. Shoulder, shaft and punch shape fine ground.

The anti-rotation surface parallel to P = 0° as standard.

Special dimensions on request.

Punch, stepped, rectangular, with ejector pin, ISO 8020



2731.

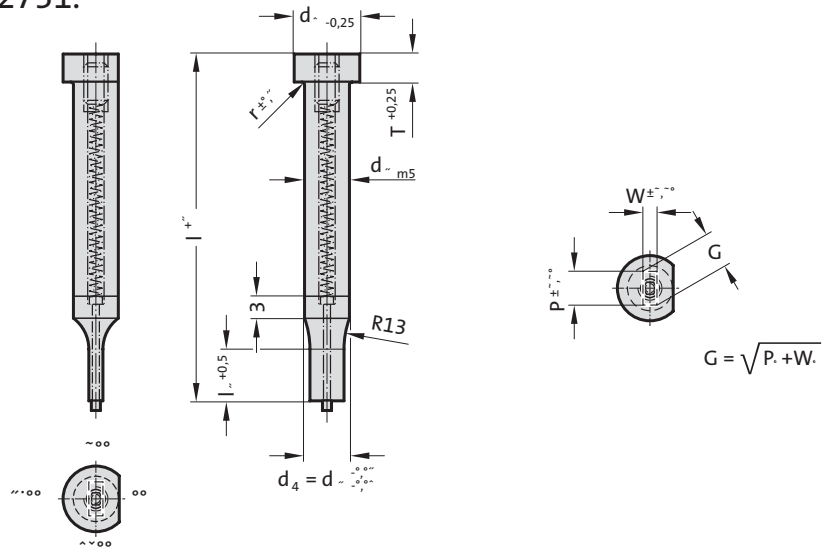

2731. Punch, stepped, rectangular, with ejector pin, ISO 8020

d ₁ / (Order No)	d ₂	W _{min}	G _{max}	l ₁ / (Order No)	r	T	l / (Order Code character)	71 (D)	80 (E)	90 (F)	100 (G)	120 (J)
5 / (3)	8	1.6	4.9	13 (3) 19 (4)	0.3	5		●	●	●	●	●
6 / (4)	9	2.5	5.9	13 (3) 19 (4)	0.3	5		●	●	●	●	●
8 / (5)	11	2.5	7.9	19 (4) 25 (5)	0.3	5		●	●	●	●	●
10 / (6)	13	4	9.9	19 (4) 25 (5)	0.3	5		●	●	●	●	●
13 / (7)	16	5	12.9	19 (4) 25 (5)	0.4	5		●	●	●	●	●
16 / (8)	19	8	15.9	19 (4) 25 (5)	0.4	5		●	●	●	●	●
20 / (9)	23	12	19.9	19 (4) 25 (5)	0.4	5		●	●	●	●	●
25 / (10)	28	16.5	24.9	19 (4) 25 (5)	0.4	5		●	●	●	●	●
32 / (11)	35	20	31.9	25 (5) 30 (6)	0.4	5		●	●	●	●	●

Material:

HSS
 Hardness:
 Shaft 64 ± 2 HRC
 Head 52 ± 5 HRC

Execution:

Punch head hot upset-forged. Shoulder, shaft and punch shape fine ground.
 The anti-rotation surface parallel to P = 0° as standard.
 Special dimensions on request.

Ordering-code (example):

2731.9F4.1504.1210B

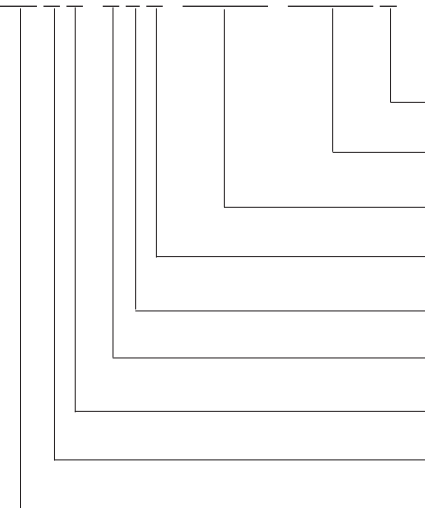

Angle: 90°
Format: Rectangular, width W W = 12,1 mm
Format: Rectangular, length P P = 15,04 mm
Punch cutting length: l₁ 19 mm
Length: l 90 mm
Diameter: d₁ 20 mm
Type: ISO
Version: Rectangular
Punch: with ejector pin

Order code character = (B)
Order code character = 1210
Order No = 1504
Order code character = (4)
Order code character = (F)
Order No = (9)
Order No = (1)
Order No = (3)
Order No = 27



Punch, stepped, slot, with ejector pin, ISO 8020

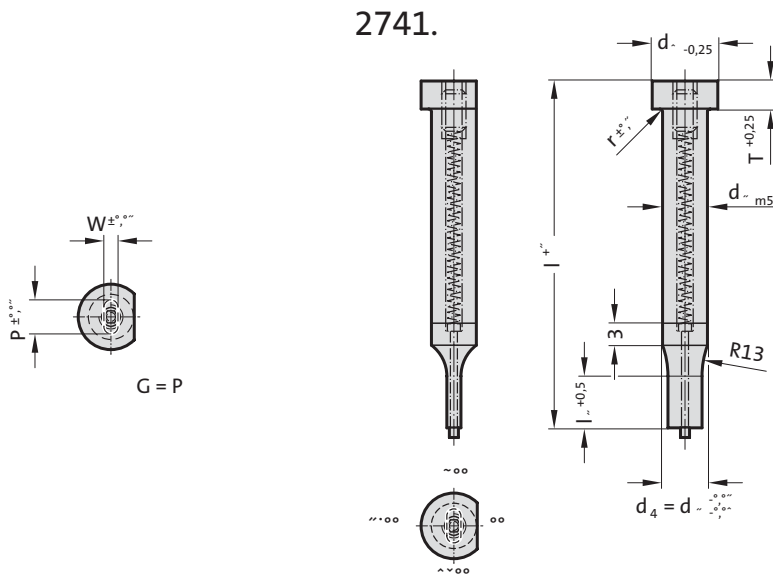

2741. Punch, stepped, slot, with ejector pin, ISO 8020

d ₁ / (Order No)	d ₂	W _{min}	G _{max}	l ₁ / (Order No)	r	T	l / (Order Code character)	71 (D)	80 (E)	90 (F)	100 (G)	120 (J)
5 / (3)	8	1.6	4.9	13 (3) 19 (4)	0.3	5		●	●	●	●	●
6 / (4)	9	2.5	5.9	13 (3) 19 (4)	0.3	5		●	●	●	●	●
8 / (5)	11	2.5	7.9	19 (4) 25 (5)	0.3	5		●	●	●	●	●
10 / (6)	13	4	9.9	19 (4) 25 (5)	0.3	5		●	●	●	●	●
13 / (7)	16	5	12.9	19 (4) 25 (5)	0.4	5		●	●	●	●	●
16 / (8)	19	8	15.9	19 (4) 25 (5)	0.4	5		●	●	●	●	●
20 / (9)	23	12	19.9	19 (4) 25 (5)	0.4	5		●	●	●	●	●
25 / (10)	28	16.5	24.9	19 (4) 25 (5)	0.4	5		●	●	●	●	●
32 / (11)	35	20	31.9	25 (5) 30 (6)	0.4	5		●	●	●	●	●

Ordering-code (example):

27 41.10 D 4. 2040.1650 B

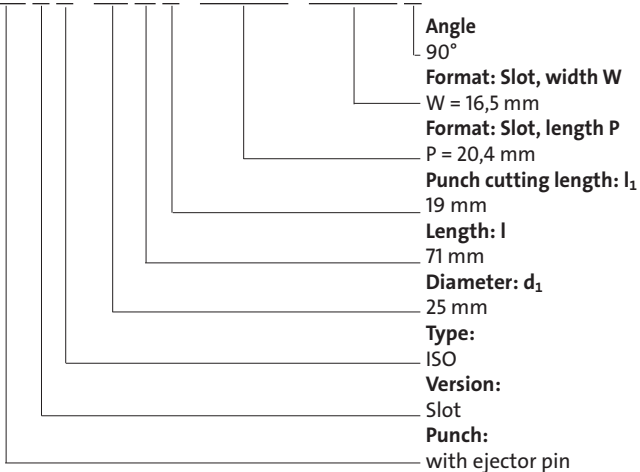

Order code character
 = (B)
 = 1650
 = 2040
Order No
 = (4)
Order code character
 = (D)
Order No
 = (10)
Order No
 = (1)
Order No
 = (4)
 = 27

Material:

HSS
 Hardness:
 Shaft 64 ± 2 HRC
 Head 52 ± 5 HRC

Execution:

Punch head hot upset-forged. Shoulder, shaft and punch shape fine ground.
 The anti-rotation surface parallel to P = 0° as standard.
 Special dimensions on request.

Punch, stepped, rectangle with radiussed corners, with ejector pin, ISO 8020



2751.

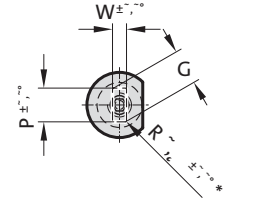
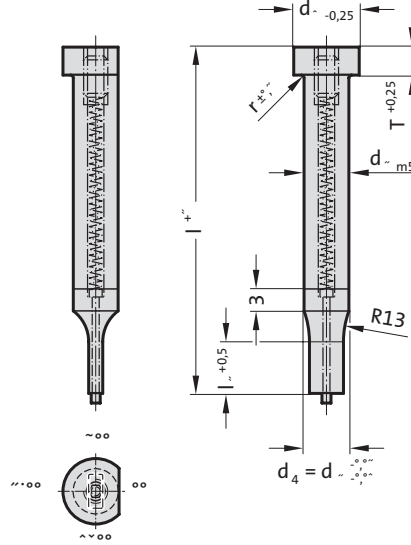

$$G = \sqrt{(P-\cdot)^2 + (W-\cdot)^2} + \cdot$$

2751. Punch, stepped, rectangle with radiussed corners, with ejector pin, ISO 8020

d ₁ / (Order No)	d ₂	W _{min}	G _{max}	l ₁ / (Order No)	r	T	l / (Order Code character)	71 (D)	80 (E)	90 (F)	100 (G)	120 (J)
5 / (3)	8	1.6	4.9	13 (3) 19 (4)	0.3	5		●	●	●	●	●
6 / (4)	9	2.5	5.9	13 (3) 19 (4)	0.3	5		●	●	●	●	●
8 / (5)	11	2.5	7.9	19 (4) 25 (5)	0.3	5		●	●	●	●	●
10 / (6)	13	4	9.9	19 (4) 25 (5)	0.3	5		●	●	●	●	●
13 / (7)	16	5	12.9	19 (4) 25 (5)	0.4	5		●	●	●	●	●
16 / (8)	19	8	15.9	19 (4) 25 (5)	0.4	5		●	●	●	●	●
20 / (9)	23	12	19.9	19 (4) 25 (5)	0.4	5		●	●	●	●	●
25 / (10)	28	16.5	24.9	19 (4) 25 (5)	0.4	5		●	●	●	●	●
32 / (11)	35	20	31.9	25 (5) 30 (6)	0.4	5		●	●	●	●	●



Material:

HSS
Hardness:
Shaft 64 ± 2 HRC
Head 52 ± 5 HRC

Execution:

Punch head hot upset-forged. Shoulder, shaft and punch shape fine ground.
The anti-rotation surface parallel to P = 0° as standard.
Special dimensions on request.
* For other radius options, see standardised special shapes.

Ordering-code (example):

27 51.9 F4.1540.1210 B

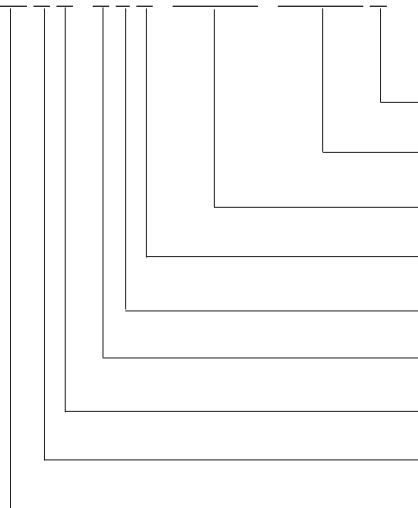

Angle: 90°
Format: Rectangle with radiussed corners, width W
W = 12,1 mm
Format: Rectangle with radiussed corners, length P
P = 15,4 mm
Punch cutting length: l₁
19 mm
Length: l
90 mm
Diameter: d₁
20 mm
Type: ISO
Version: Rectangle with radiussed corners = (5)
Punch: with ejector pin = 27

Order code character = (B)
Order No = 1210
Order No = 1540
Order No = (4)
Order code character = (F)
Order No = (9)
Order No = (1)
Order No = (5)



Pilot pin with tapered tip, ISO 8020

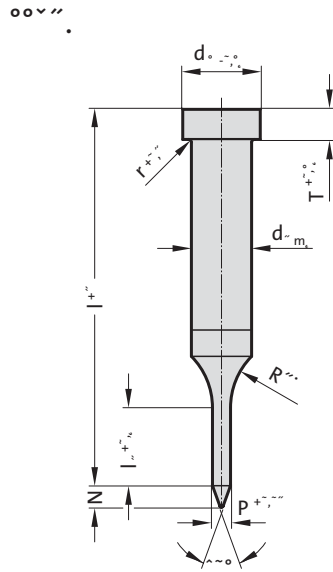

2261. Pilot pin with tapered tip, ISO 8020

d ₁ / (Order No)	d ₂	T	P	l ₁ / (Order No)	N	l / (Order Code character)	63 (C)	71 (D)	80 (E)	90 (F)	100 (G)	110 (H)	125 (K)	140 (L)
5 / (3)	8	5	1,0-4,9	13 (3)	4		●	●						
6 / (4)	9	5	1,6-5,9	13 (3)	5		●	●	●					
8 / (5)	11	5	2,5-7,9	13 (3)	6		●	●	●	●				
10 / (6)	13	5	4,0-9,9	13 (3) 19 (4)	8		●	●	●	●	●			
13 / (7)	16	5	5,0-12,9	13 (3) 19 (4)	10		●	●	●	●	●	●		
16 / (8)	19	5	8,0-15,9	13 (3) 19 (4) 25 (5)	15			●	●	●	●	●	●	●
20 / (9)	23	5	12,0-19,9	13 (3) 19 (4) 25 (5)	20			●	●	●	●	●	●	●
25 / (10)	28	5	16,5-24,9	13 (3) 19 (4) 25 (5)	25			●	●	●	●	●	●	●
32 / (11)	35	5	20,0-31,9	19 (4) 25 (5)	30				●	●	●	●	●	●

Ordering-code (example):

2 2 6 1 . 1 0 D 3 . 1 7 5 0

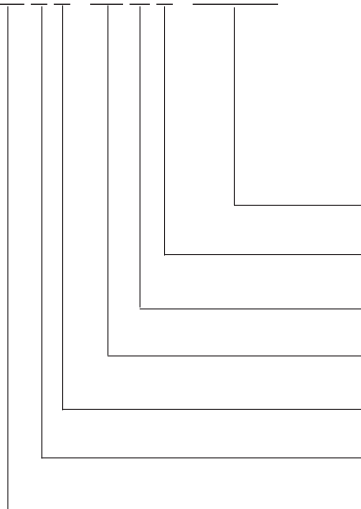

Format: Round
 P = Ø 17,5 mm = 1750
Punch cutting length: l₁
 13 mm **Order No**
 = (3)
Length: l
 71 mm **Order code character**
 = (D)
Diameter: d₁
 25 mm **Order No**
 = (10)
Type:
 ISO **Order No**
 = (1)
Version:
 Pilot pin with tapered tip **Order No**
 = (6)
Punch:
 without ejector pin = 22

Material:

HSS
 Hardness:
 Shaft 64 ± 2 HRC
 Head 52 ± 5 HRC

Execution:

Head hot upset-forged. Shoulder, shaft and pilot fine ground.
 Special dimensions on request.

Pilot pin with parabolic tip, ISO 8020

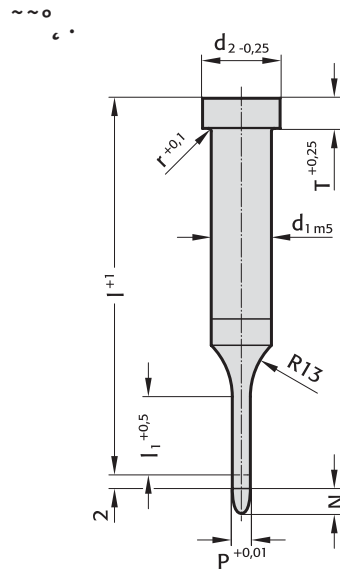

2271. Pilot pin with parabolic tip, ISO 8020

d ₁ / (Order No)	d ₂	T	P	l ₁ / (Order No)	l / (Order Code character)	50 (A)	56 (B)	63 (C)	71 (D)	80 (E)	90 (F)	100 (G)
5 / (3)	8	5	1,0-4,9	10 (2) 13 (3)		●	●	●	●			
6 / (4)	9	5	1,6-5,9	10 (2) 13 (3)		●	●	●	●	●		
8 / (5)	11	5	2,5-7,9	10 (2) 13 (3)		●	●	●	●	●		
10 / (6)	13	5	4,0-9,9	10 (2) 13 (3) 19 (4)		●	●	●	●	●	●	●
13 / (7)	16	5	5,0-12,9	10 (2) 13 (3) 19 (4)		●	●	●	●	●	●	●
16 / (8)	19	5	8,0-15,9	13 (3) 19 (4)		●	●	●	●	●	●	●
20 / (9)	23	5	12,0-19,9	13 (3) 19 (4)		●	●	●	●	●	●	●
25 / (10)	28	5	16,5-24,9	13 (3) 19 (4)			●	●	●	●	●	●
32 / (11)	35	5	20,0-31,9	19 (4)					●	●	●	●

Material:

HSS
 Hardness:
 Shaft 64 ± 2 HRC
 Head 52 ± 5 HRC

Execution:

Head hot upset-forged. Shoulder, shaft and pilot fine ground.
 Special dimensions on request.

Note:

The 2 mm length provides full guidance before the blanking punch contacts the sheet metal.

Length of parabolic tip N:

= 8 mm where P ≤ 10 mm
 =12 mm where P 10,1 mm - 15 mm
 =15 mm where P > 15 mm

Ordering-code (example):

2 2 7 1 . 1 0 D 3 . 1 7 5 0

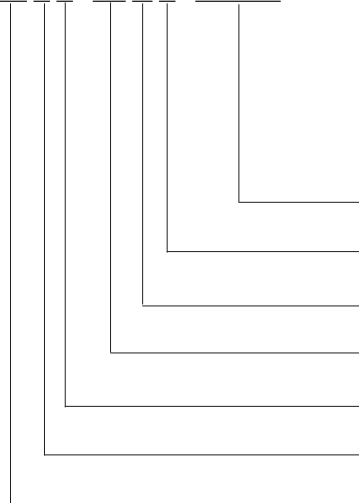

Format: Round

P = Ø 17,5 mm

Punch cutting length: l₁
 13 mm

Length: l

71 mm

Diameter: d₁

25 mm

Type:

ISO

Version:

Pilot pin with parabolic tip

Punch:

without ejector pin

= 1750

Order No

= (3)

Order code character

= (D)

Order No

= (10)

Order No

= (1)

Order No

= (7)

= 22

Pilot unit to Mercedes-Benz Standard

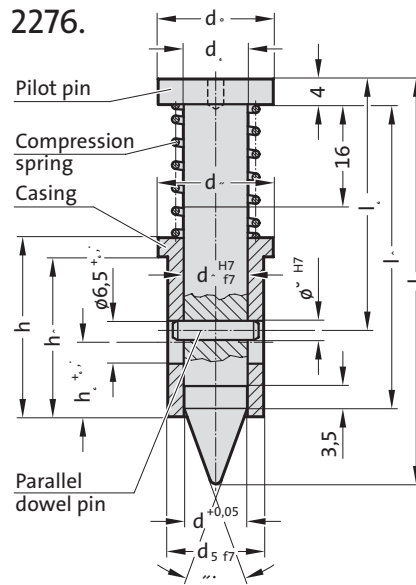

2276. Pilot unit to Mercedes-Benz Standard

Order No	d	d ₁	d ₂	d ₃	d ₄	d ₅	h	h ₁	h ₂	l ₁	l ₂	l	Spring force preloaded [daN]	Spring force pressed [daN]
2276.1.A.0980	9.8	10	10	18	18	15	28	25	12	47.5	39.3	63.2	4.9	6.2
2276.2.B.1580	15.8	16	16	24	30	26	28	25	12	54.5	46.3	72.5	4.8	5.6

Ordering-code (example):

2 2 7 6 . 1 . A . 0 9 8 0

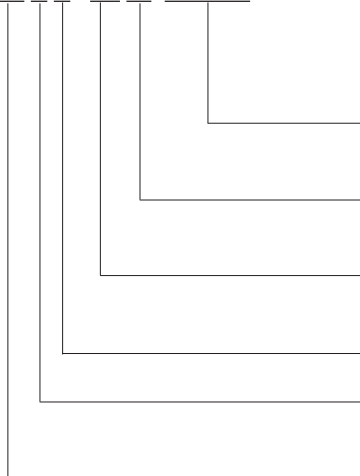

Diameter: d
9,8 mm
15,8 mm
Length: l
63,2 mm
72,5 mm
Diameter: d₁
10 mm
16 mm
Standard:
Mercedes
Version:
Pilot pin

= 0980
= 1580
Order code character
= (A)
= (B)
Order No
= (1)
= (2)
Order No
= (6)
Order No
= (7)
= 22

Description:

The pilot unit provides exact positioning of sheet metal parts.

There are 2 sizes.

The pilot unit 10 (2276.1.) can be used for a hole diameter of 5 to 10 mm and is available as a finished item, 9.8 mm diameter.

The pilot unit 16 (2276.2.) is used for diameter > 10 - 16 mm and is available as a finished item, 15.8 mm diameter.

Smaller diameters have to be ground by the tool making department.

Note:

The pilot unit consists of:
Pilot pin, sleeve, compression spring, dowel pin.



Precision Matrixes



Ordering example Matrixes

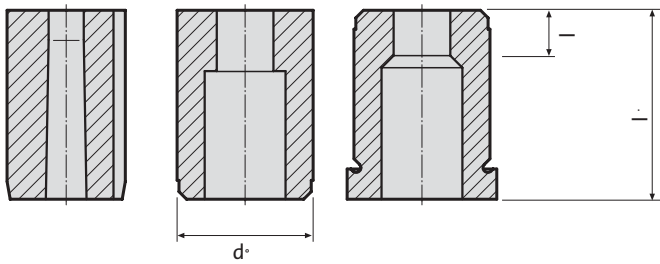

NB: See table for standard dimensions
Special dimensions to order

2 6 4 6 . 1 0 F 6 . 1 3 5 0 . 0 6 5 0 A 2

Matrixes: 26 = matrixes

Version:

○ blank (pilot hole bore)	= 0
○ round	= 1
□ square	= 2
□ rectangular	= 3
○ slot	= 4
○ rectangle with radiused corners	= 5
special shapes	= 9

Type:

automotive standard	= 5
without shoulder ISO 8977	= 6
with shoulder ISO 8977	= 7

Shape cutting length: l

2	= 1
3	= 2
4	= 3
5	= 4
6	= 5
8	= 6
10	= 7
12	= 8
special	= X

Format: Slot length P = 13,5 mm

Format: Slot width W = 6,5 mm

Order Code character

0°	= A
90°	= B
180°	= C
270°	= D
special	= X

Length: l₁

13	= A
16	= B
20	= C
22	= D
25	= E
28	= F
30	= G
32	= H
35	= J
40	= K
special	= X

Diameter: d₂

5	= 1
6	= 2
8	= 3
10	= 4
13	= 5
16	= 6
20	= 7
22	= 8
25	= 9
32	= 10
38	= 11
40	= 12
45	= 13
50	= 14
56	= 15
63	= 16
71	= 17
76	= 18
85	= 19
90	= 20
100	= 21

Order Code character

pin Ø3	= 1
pin Ø4	= 2
pin Ø6	= 3
polished surface (continuous)	= 4
polished surface top, 14 mm	= 5
polished surface bottom, 14 mm	= 6
special	= X

Ordering Code (Example):

2 6 4 6 . 1 0 F 6 . 1 3 5 0 . 0 6 5 0 A 2

Anti-rotation element: Pin Ø = 4 mm (2)

Angle = 0° (A)

Format: Slot width W = 6,5 mm (0650)

Format: Slot length P = 13,5 mm (1350)

Shape cutting length: l = 8 mm (6)

Length: l₁ = 28 mm (F)

Diameter: d₂ = 32 mm (10)

Type = without shoulder ISO 8977 (6)

Version: Slot (4)

Matrixes: Matrixes (26)

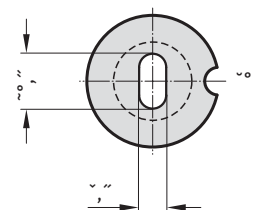
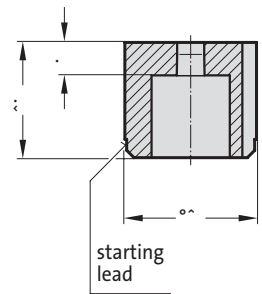

MATRIX WITHOUT SHOULDER, BLANK, ISO 8977

2606.

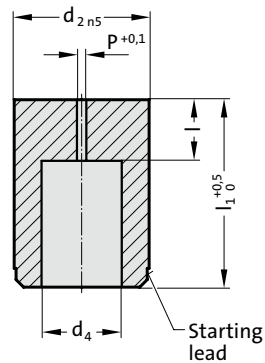

2606. Matrix without shoulder, blank, ISO 8977

d ₂ / Order No	d ₄	P	l / Order No	l ₁ / (Order Code character)	16 (B)	20 (C)	22 (D)	25 (E)	28 (F)	30 (G)	32 (H)	35 (J)	40 (K)
5 / (1)	2.8	0.8	2 (1)		●	●	●	●	●	●	●	●	
6 / (2)	3.5	1	3 (2)		●	●	●	●	●	●	●	●	
8 / (3)	4	1	4 (3)		●	●	●	●	●	●	●	●	●
10 / (4)	5.8	1	4 (3) 8 (6)		●	●	●	●	●	●	●	●	●
13 / (5)	8	1.2	5 (4) 8 (6)			●	●	●	●	●	●	●	●
16 / (6)	9.5	1.2	5 (4) 8 (6)			●	●	●	●	●	●	●	●
20 / (7)	12	1.5	8 (6) 12 (8)			●	●	●	●	●	●	●	●
22 / (8)	15	1.5	8 (6) 12 (8)			●	●	●	●	●	●	●	●
25 / (9)	17.3	1.5	8 (6) 12 (8)			●	●	●	●	●	●	●	●
32 / (10)	20.7	1.5	8 (6) 12 (8)			●	●	●	●	●	●	●	●
38 / (11)	27.7	1.5	8 (6) 12 (8)					●	●	●	●	●	●
40 / (12)	27.7	1.5	8 (6) 12 (8)					●	●	●	●	●	●
50 / (14)	37	1.5	8 (6) 12 (8)					●	●	●	●	●	●

Ordering Code (example):

2606.10F8

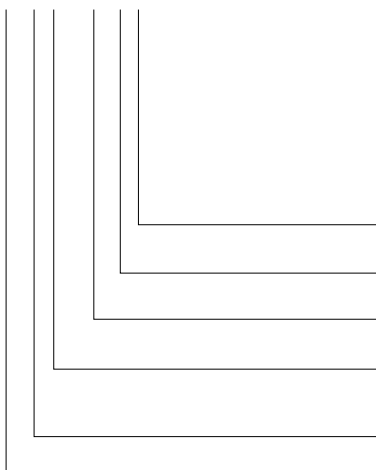

Shape cutting length: l
12 mm
Length: l₁
28 mm
Diameter: d₂
32 mm
Type:
without shoulder
ISO 8977
Execution:
blank (pilot hole bore)
Matrix

Order No
= (8)
Order Code character
= (F)
Order No
= (10)
Order No
= (6)
Order No
= (0)
Order No
= 26

Material:

HSS
Hardness 62 ± 2 HRC

Execution:

Diameter d₂, starting lead and face surfaces ground.
Diameter P is a bored pilot hole for wire EDM.
Special dimensions on request.

MATRIX WITHOUT SHOULDER, ROUND, ISO 8977



2616.

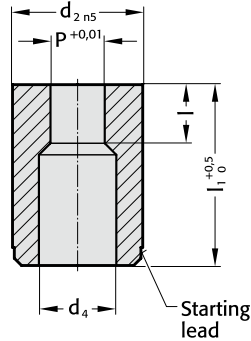

2616. Matrix without shoulder, round, ISO 8977

d ₂ / Order No	d ₄	P	l / Order No	l ₁ / (Order Code character)	16 (B)	20 (C)	22 (D)	25 (E)	28 (F)	30 (G)	32 (H)	35 (J)	40 (K)
5 / (1)	2.8	1 - 2,4	2 (1)		●	●	●	●	●	●	●	●	
6 / (2)	3.5	1,6 - 3	3 (2)		●	●	●	●	●	●	●	●	
8 / (3)	4	2 - 3,5	4 (3)		●	●	●	●	●	●	●	●	
10 / (4)	5.8	2,5 - 5	4 (3) 8 (6)		●	●	●	●	●	●	●	●	
13 / (5)	8	4 - 7	5 (4) 8 (6)			●	●	●	●	●	●	●	
16 / (6)	9.5	6 - 9	5 (4) 8 (6)			●	●	●	●	●	●	●	
20 / (7)	12	8 - 11	8 (6) 12 (8)			●	●	●	●	●	●	●	
22 / (8)	15	9 - 14	8 (6) 12 (8)			●	●	●	●	●	●	●	
25 / (9)	17.3	10,7 - 16	8 (6) 12 (8)			●	●	●	●	●	●	●	
32 / (10)	20.7	15 - 20	8 (6) 12 (8)			●	●	●	●	●	●	●	
38 / (11)	27.7	19 - 27	8 (6) 12 (8)					●	●	●	●	●	
40 / (12)	27.7	19 - 27	8 (6) 12 (8)					●	●	●	●	●	
50 / (14)	37	26 - 36	8 (6) 12 (8)					●	●	●	●	●	●

Material:

HSS
Hardness 62 ± 2 HRC

Execution:

Diameter d₂, starting lead and face surfaces ground.
Special dimensions on request.

Ordering Code (example): without anti-rotation element

2616.10F8.1510

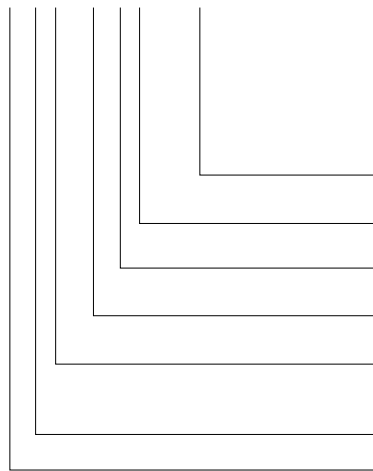

Shape: round
P = ø15,1 mm
Shape cutting length: l
12 mm
Length: l₁
28 mm
Diameter: d₂
32 mm
Type:
without shoulder
ISO 8977
Execution:
round
Matrix

= 1510
Order No
= (8)
Order Code character
= (F)
Order No
= (10)
Order No
= (6)
Order No
= (1)
= 26

MATRIXES WITHOUT SHOULDER, CYLINDRICAL, ISO 8977, ANTI-ROTATION ELEMENTS

Anti-rotation element 1 (1)

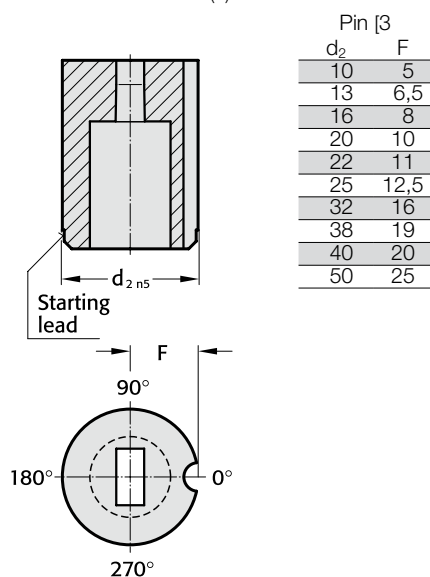

Anti-rotation element 2 (2)

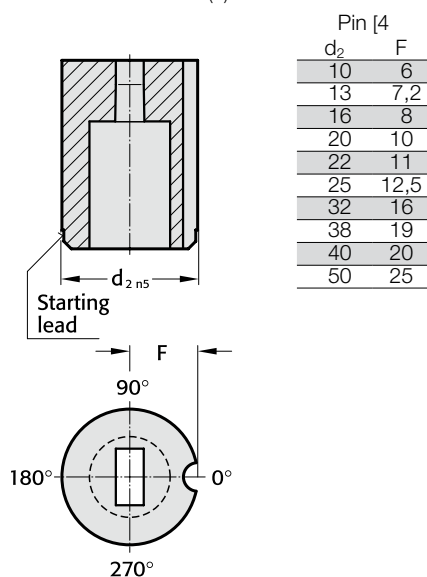

Anti-rotation element 3 (3)

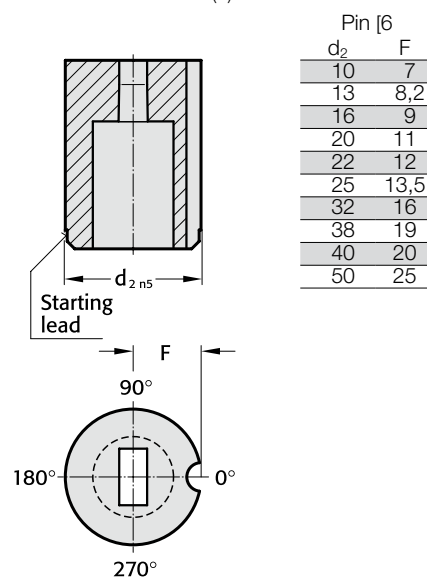

Anti-rotation element 4 (4)

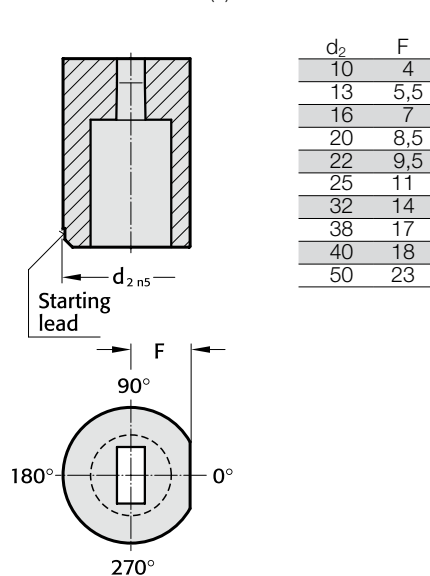

Anti-rotation element 5 (5)

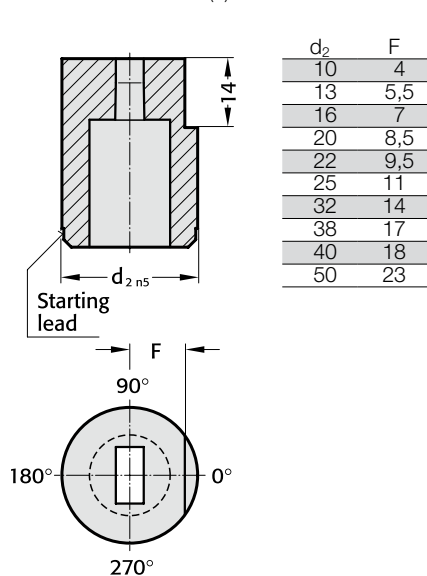

Anti-rotation element 6 (6)

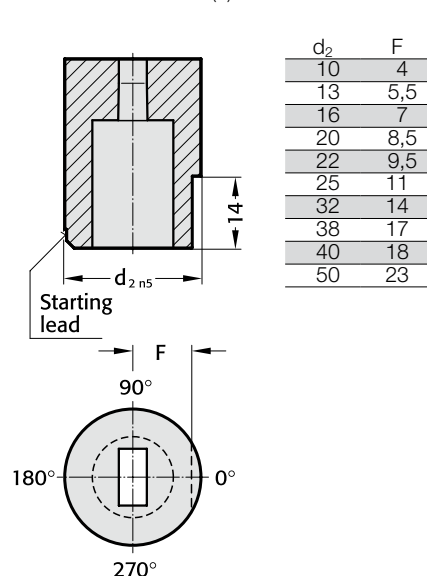

Ordering Code (example): with anti-rotation element from d₂ ≥ 10 mm

2616.10F8.1510.A4

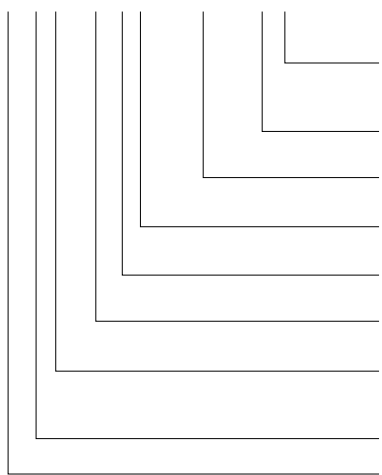

Anti-rotation element:
Polished surface
(continuous)
Angle:
0°
Shape: round
P = ø 15,1 mm
Shape cutting length: l
12 mm
Length: l₁
28 mm
Diameter: d₂
32 mm
Type:
without shoulder
ISO 8977
Execution:
round
Matrix

Order No
= (4)
Order Code character
= (A)
= 1510
Order No
= (8)
Order Code character
= (F)
Order No
= (10)
Order No
= (6)
Order No
= (1)
= 26

MATRIX WITHOUT SHOULDER, SQUARE, ISO 8977



2626.

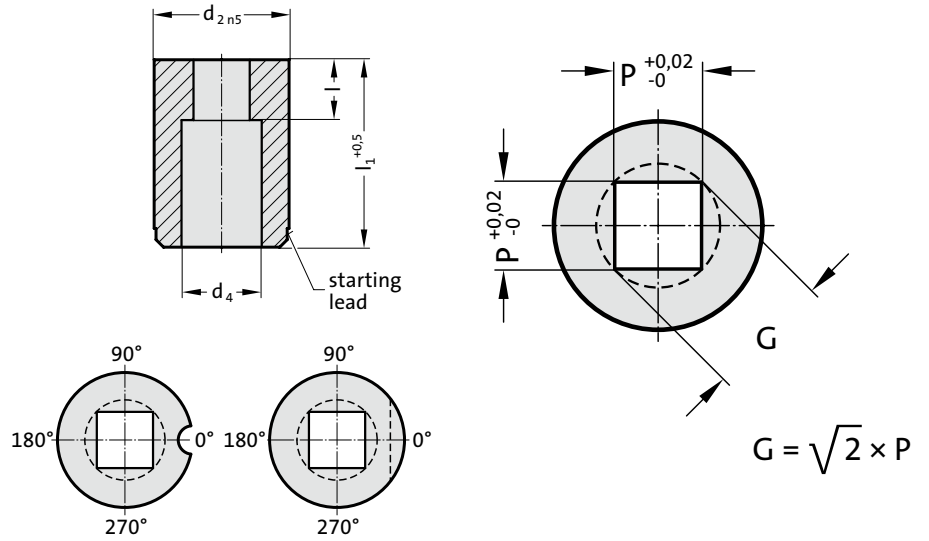

2626. Matrix without shoulder, square, ISO 8977

d ₂ / Order No	d ₄	P _{min}	G _{max}	l / Order No	l ₁ / (Order Code character)	16 (B)	20 (C)	22 (D)	25 (E)	28 (F)	30 (G)	32 (H)	35 (J)	40 (K)
10 / (4)	5.8	1.2	5	4 (3) 8 (6)		●	●	●	●	●	●	●	●	●
13 / (5)	8	2	7	5 (4) 8 (6)			●	●	●	●	●	●	●	●
16 / (6)	9.5	2.4	9	5 (4) 8 (6)			●	●	●	●	●	●	●	●
20 / (7)	12	3.2	11	8 (6) 12 (8)			●	●	●	●	●	●	●	●
22 / (8)	15	4	14	8 (6) 12 (8)			●	●	●	●	●	●	●	●
25 / (9)	17.3	4.8	16	8 (6) 12 (8)			●	●	●	●	●	●	●	●
32 / (10)	20.7	5.5	20	8 (6) 12 (8)			●	●	●	●	●	●	●	●
38 / (11)	27.7	6.4	27	8 (6) 12 (8)					●	●	●	●	●	●
40 / (12)	27.7	6.4	27	8 (6) 12 (8)					●	●	●	●	●	●
50 / (14)	37	9	36	8 (6) 12 (8)					●	●	●	●	●	●

Material:

HSS
Hardness 62 ± 2 HRC

Execution:

Diameter d₂, starting lead and face surfaces ground.
Special dimensions on request.

Ordering Code (example): with anti-rotation element

2626.10F8.1350.A3

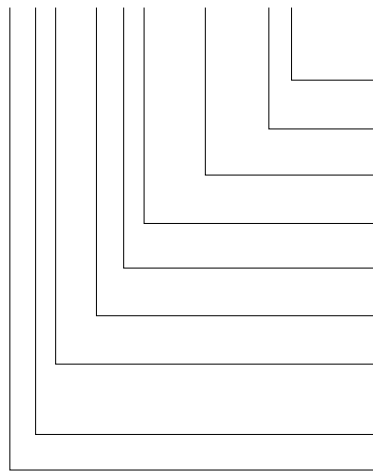

Anti-rotation element:

Pin ∅ 6 mm

Angle:

0°

Shape: square, Length P

P = 13,5 mm

Shape cutting length: l

12 mm

Length: l₁

28 mm

Diameter: d₂

32 mm

Type:

without shoulder
ISO 8977

Execution:

square

Matrix

Order No

= (3)

Order Code character

= (A)

= 1350

Order No

= (8)

Order Code character

= (F)

Order No

= (10)

Order No

= (6)

Order No

= (2)

= 26

MATRIXES WITHOUT SHOULDER, CYLINDRICAL, ISO 8977, ANTI-ROTATION ELEMENTS

Anti-rotation element 1 (1)

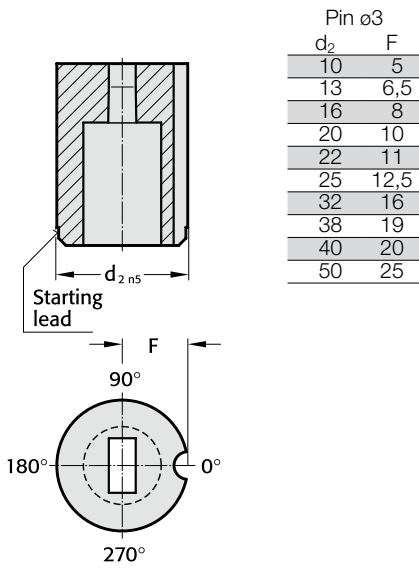

Anti-rotation element 2 (2)

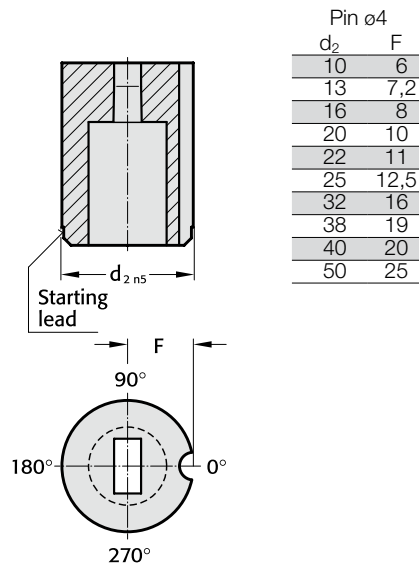

Anti-rotation element 3 (3)

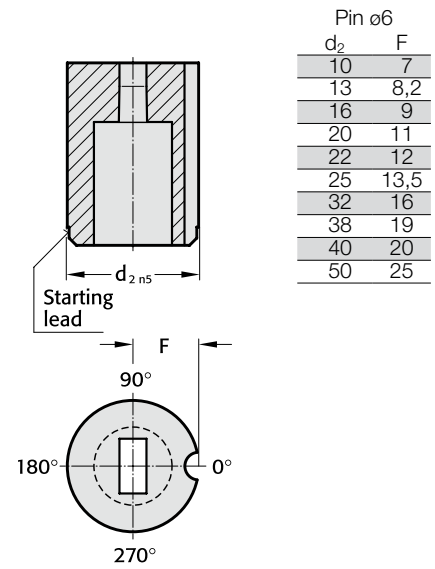

Anti-rotation element 4 (4)

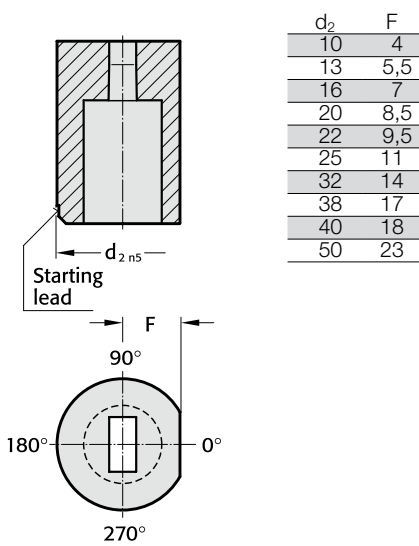

Anti-rotation element 5 (5)

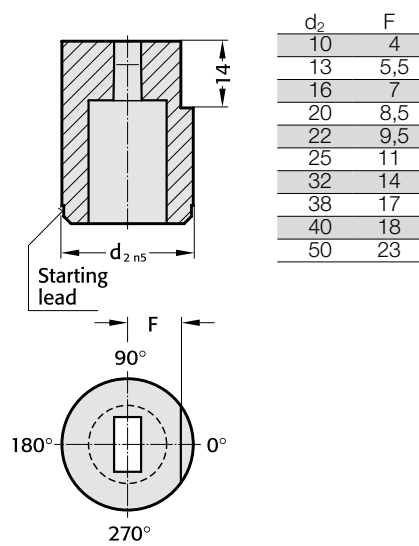

Anti-rotation element 6 (6)

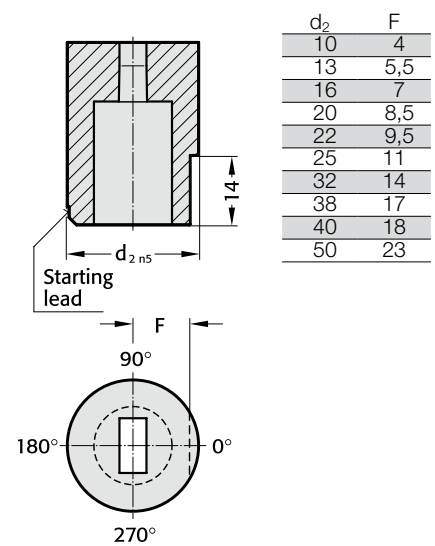

MATRIX WITHOUT SHOULDER, RECTANGULAR, ISO 8977



2636.

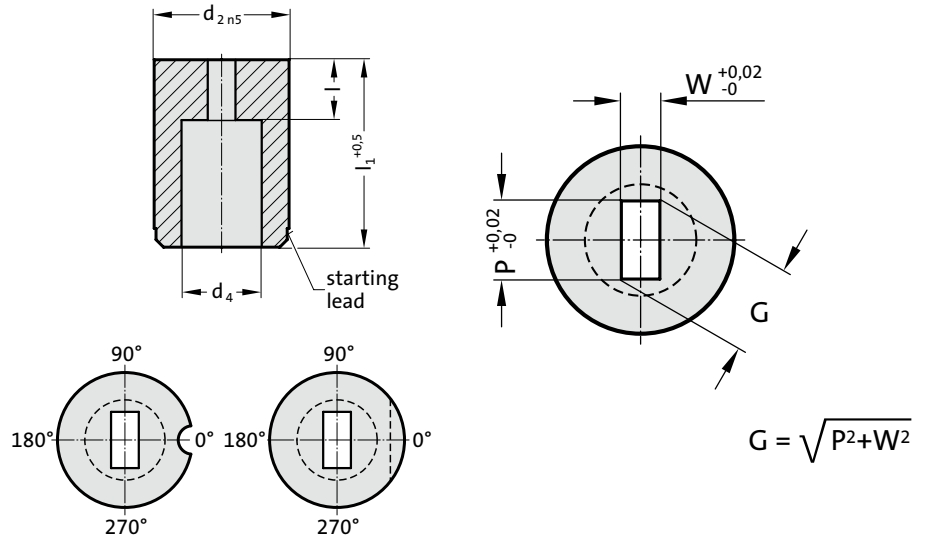

2636. Matrix without shoulder, rectangular, ISO 8977

d ₂ / Order No	d ₄	W _{min}	G _{max}	l / Order No	l ₁ / (Order Code character)	16 (B)	20 (C)	22 (D)	25 (E)	28 (F)	30 (G)	32 (H)	35 (J)	40 (K)
10 / (4)	5.8	1.2	5	4 (3) 8 (6)		●	●	●	●	●	●	●	●	●
13 / (5)	8	2	7	5 (4) 8 (6)			●	●	●	●	●	●	●	●
16 / (6)	9.5	2.4	9	5 (4) 8 (6)			●	●	●	●	●	●	●	●
20 / (7)	12	3.2	11	8 (6) 12 (8)			●	●	●	●	●	●	●	●
22 / (8)	15	4	14	8 (6) 12 (8)			●	●	●	●	●	●	●	●
25 / (9)	17.3	4.8	16	8 (6) 12 (8)			●	●	●	●	●	●	●	●
32 / (10)	20.7	5.5	20	8 (6) 12 (8)			●	●	●	●	●	●	●	●
38 / (11)	27.7	6.4	27	8 (6) 12 (8)					●	●	●	●	●	●
40 / (12)	27.7	6.4	27	8 (6) 12 (8)					●	●	●	●	●	●
50 / (14)	37	9	36	8 (6) 12 (8)					●	●	●	●	●	●

Material:

HSS
Hardness 62 ± 2 HRC

Execution:

Diameter d₂, starting lead and face surfaces ground.
Special dimensions on request.

Ordering Code (example): with anti-rotation element

2636.10F8.1350.0650.B4

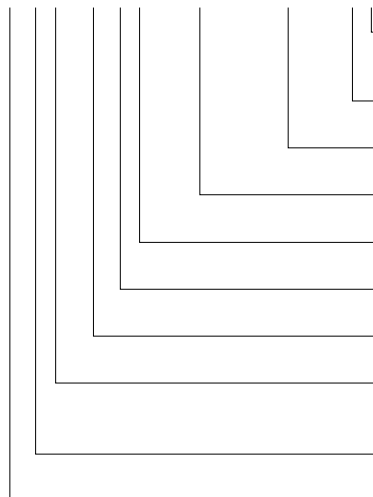

Anti-rotation element:

Polished surface
(continuous)

Angle:

90°

Shape: rectangular, Width W

W = 6,5 mm

Shape: rectangular, Length P

P = 13,5 mm

Shape cutting length: l

12 mm

Length: l₁

28 mm

Diameter: d₂

32 mm

Type:

without shoulder
ISO 8977

Execution:

rectangular

Matrix

Order No

= (4)

Order Code character

= (B)

= 0650

= 1350

Order No

= (8)

Order Code character

= (F)

Order No

= (10)

Order No

= (6)

Order No

= (3)

= 26

MATRIXES WITHOUT SHOULDER, CYLINDRICAL, ISO 8977, ANTI-ROTATION ELEMENTS

Anti-rotation element 1 (1)

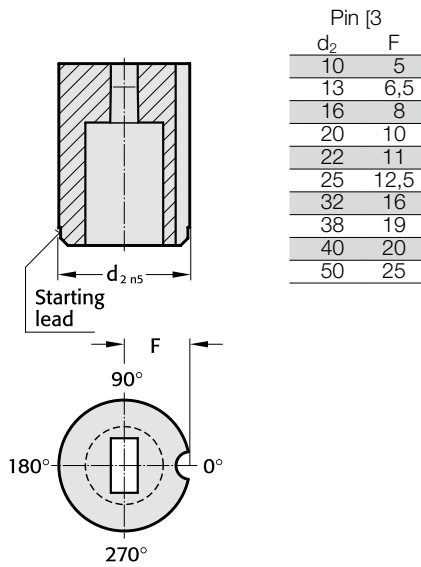

Anti-rotation element 2 (2)

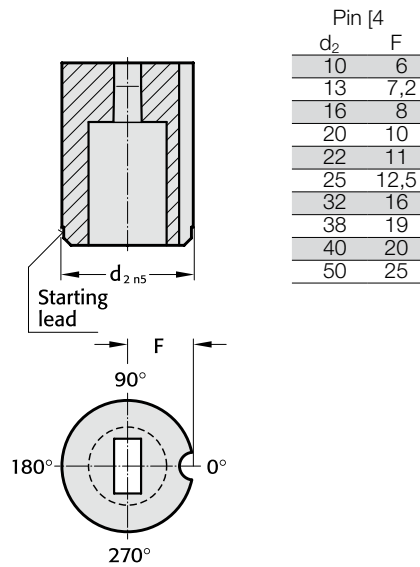

Anti-rotation element 3 (3)

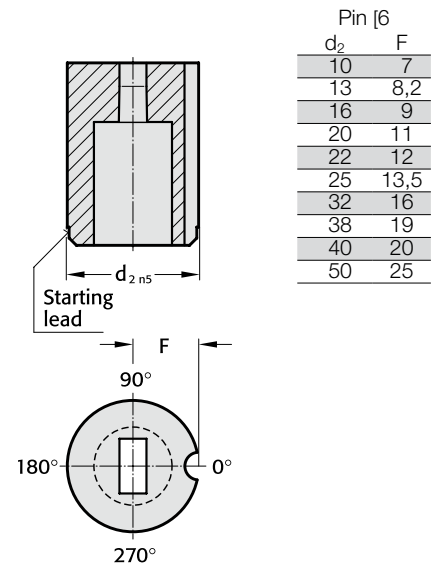

Anti-rotation element 4 (4)

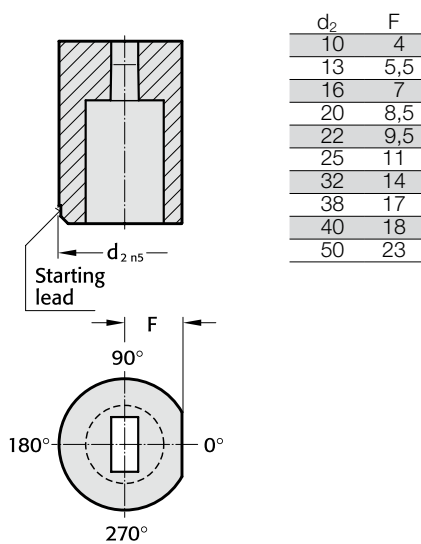

Anti-rotation element 5 (5)

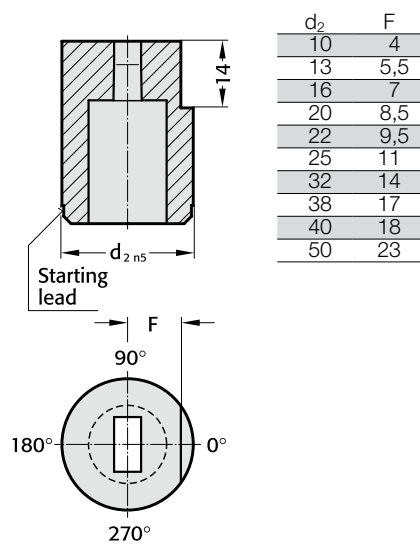

Anti-rotation element 6 (6)

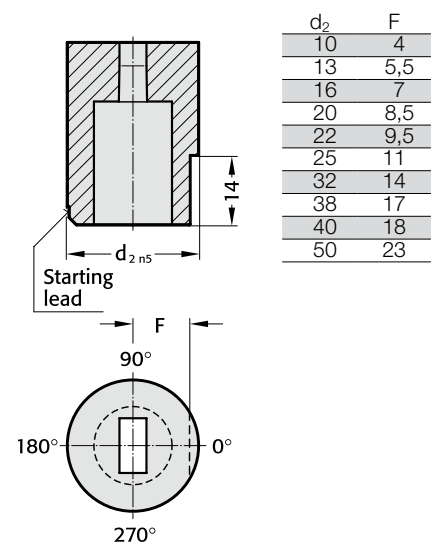

MATRIX WITHOUT SHOULDER, SLOT, ISO 8977



2646.

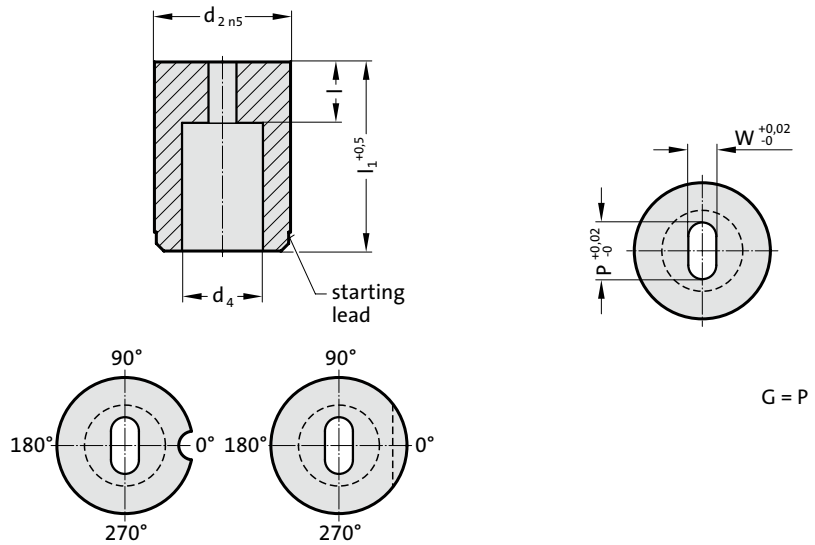

2646. Matrix without shoulder, slot, ISO 8977

d ₂ / Order No	d ₄	W _{min}	G _{max}	l / Order No	l ₁ / (Order Code character)	16 (B)	20 (C)	22 (D)	25 (E)	28 (F)	30 (G)	32 (H)	35 (J)	40 (K)
10 / (4)	5.8	1.2	5	4 (3) 8 (6)		●	●	●	●	●	●	●	●	●
13 / (5)	8	2	7	5 (4) 8 (6)			●	●	●	●	●	●	●	●
16 / (6)	9.5	2.4	9	5 (4) 8 (6)			●	●	●	●	●	●	●	●
20 / (7)	12	3.2	11	8 (6) 12 (8)			●	●	●	●	●	●	●	●
22 / (8)	15	4	14	8 (6) 12 (8)			●	●	●	●	●	●	●	●
25 / (9)	17.3	4.8	16	8 (6) 12 (8)			●	●	●	●	●	●	●	●
32 / (10)	20.7	5.5	20	8 (6) 12 (8)			●	●	●	●	●	●	●	●
38 / (11)	27.7	6.4	27	8 (6) 12 (8)					●	●	●	●	●	●
40 / (12)	27.7	6.4	27	8 (6) 12 (8)					●	●	●	●	●	●
50 / (14)	37	9	36	8 (6) 12 (8)					●	●	●	●	●	●

Material:

HSS

Hardness 62 ± 2 HRC

Execution:

Diameter d₂, starting lead and face surfaces ground.

Special dimensions on request.

Ordering Code (example): with anti-rotation element

2646.10F8.1350.0650.B2

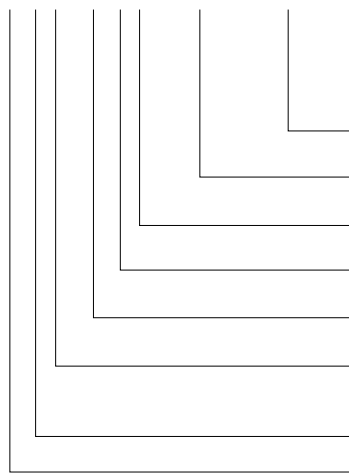

Anti-rotation element:

Pin Ø 4 mm

Angle:

90°

Shape: slot, Width W

W = 6,5 mm

Shape: slot, Length P

P = 13,5 mm

Shape cutting length: l

12 mm

Length: l₁

28 mm

Diameter: d₂

32 mm

Type:

without shoulder

ISO 8977

Execution:

slot

Matrix

Order No

= (2)

Order Code character

= (B)

= 0650

= 1350

Order No

= (8)

Order Code character

= (F)

Order No

= (10)

Order No

= (6)

Order No

= (4)

= 26

MATRIXES WITHOUT SHOULDER, CYLINDRICAL, ISO 8977, ANTI-ROTATION ELEMENTS

Anti-rotation element 1 (1)

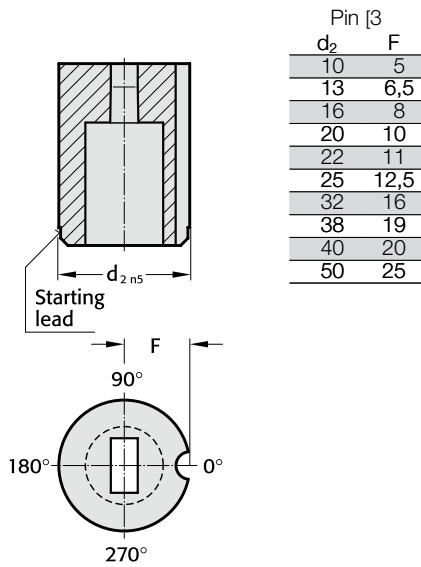

Anti-rotation element 2 (2)

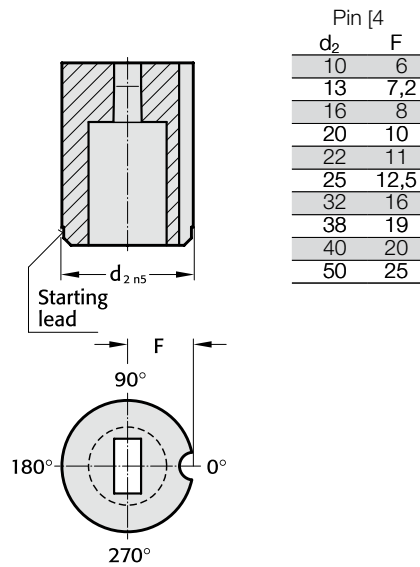

Anti-rotation element 3 (3)

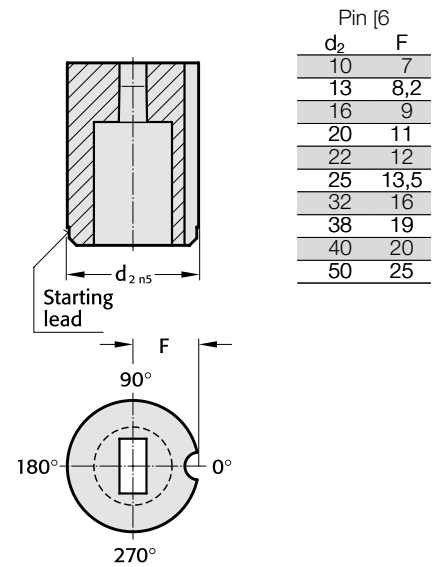

Anti-rotation element 4 (4)

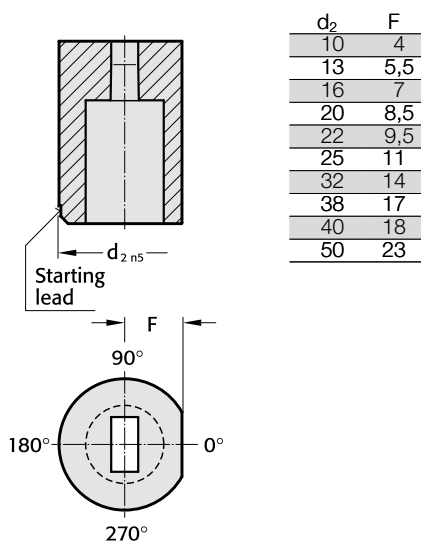

Anti-rotation element 5 (5)

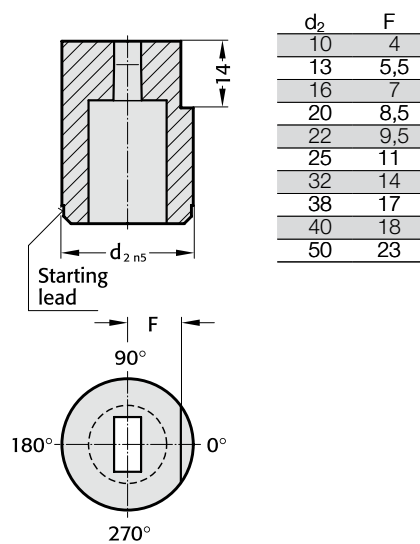

Anti-rotation element 6 (6)

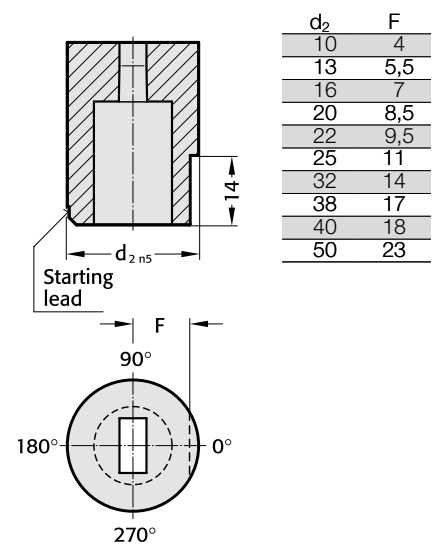

MATRIX WITHOUT SHOULDER, RECTANGLE WITH RADIUSSED CORNERS, ISO 8977

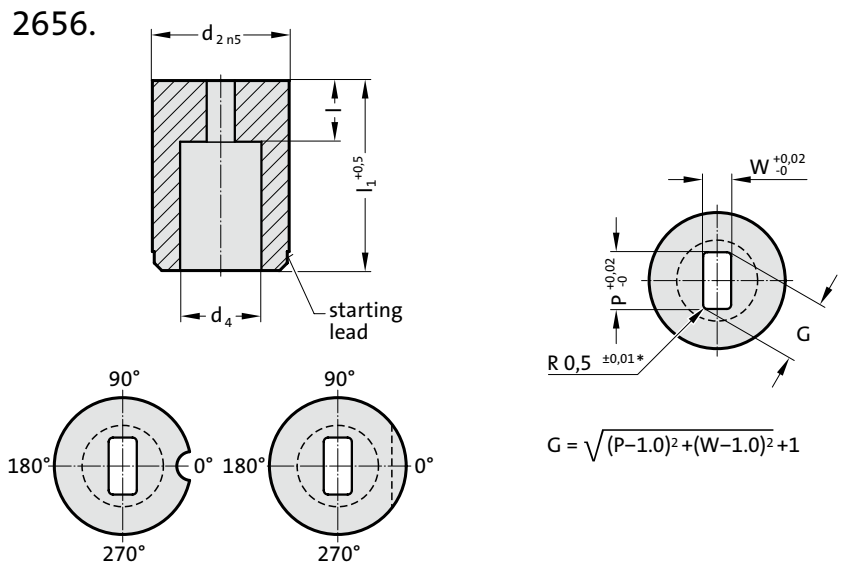

2656. Matrix without shoulder, rectangle with radiused corners, ISO 8977

d ₂ / Order No	d ₄	W _{min}	G _{max}	l / Order No	l ₁ / (Order Code character)	16 (B)	20 (C)	22 (D)	25 (E)	28 (F)	30 (G)	32 (H)	35 (J)	40 (K)
10 / (4)	5.8	1.2	5	4 (3) 8 (6)		●	●	●	●	●	●	●	●	
13 / (5)	8	2	7	5 (4) 8 (6)			●	●	●	●	●	●	●	
16 / (6)	9.5	2.4	9	5 (4) 8 (6)			●	●	●	●	●	●	●	
20 / (7)	12	3.2	11	8 (6) 12 (8)			●	●	●	●	●	●	●	
22 / (8)	15	4	14	8 (6) 12 (8)			●	●	●	●	●	●	●	
25 / (9)	17.3	4.8	16	8 (6) 12 (8)			●	●	●	●	●	●	●	
32 / (10)	20.7	5.5	20	8 (6) 12 (8)			●	●	●	●	●	●	●	
38 / (11)	27.7	6.4	27	8 (6) 12 (8)					●	●	●	●	●	
40 / (12)	27.7	6.4	27	8 (6) 12 (8)					●	●	●	●	●	
50 / (14)	37	9	36	8 (6) 12 (8)					●	●	●	●	●	●

Material:

HSS
Hardness 62 ± 2 HRC

Execution:

Diameter d₂, starting lead and face surfaces ground.

Special dimensions on request.

* For other radius options, see standardised special shapes.

Ordering Code (example): with anti-rotation element

2656.10F8.1350.0650.A1

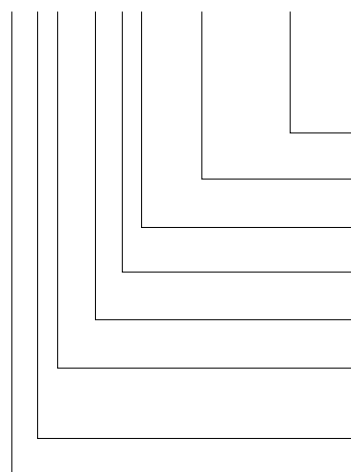

Anti-rotation element:

Pin Ø 3 mm

Angle:

0°

Shape: rectangle with radiused corners, Width W

W = 6,5 mm

Shape: rectangle with radiused corners, Length P

P = 13,5 mm

Shape cutting length: l

12 mm

Length: l₁

28 mm

Diameter: d₂

32 mm

Type:

without shoulder
ISO 8977

Execution:

rectangle with radiused corners

Matrix

Order No

= (1)

Order Code character

= (A)

Order Code character

= 0650

Order Code character

= 1350

Order No

= (8)

Order Code character

= (F)

Order No

= (10)

Order No

= (6)

Order No

= (5)

Order No

= 26

MATRIXES WITHOUT SHOULDER, CYLINDRICAL, ISO 8977, ANTI-ROTATION ELEMENTS

Anti-rotation element 1 (1)

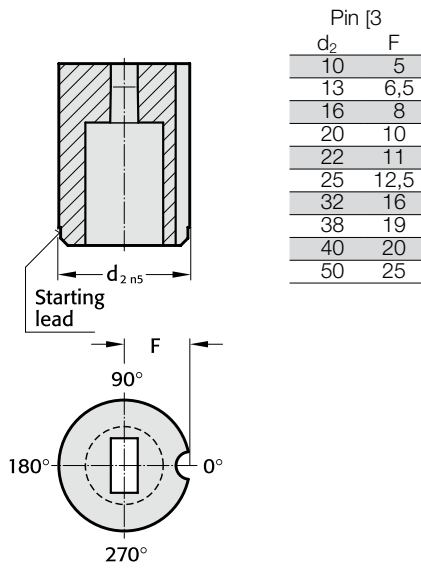

Anti-rotation element 2 (2)

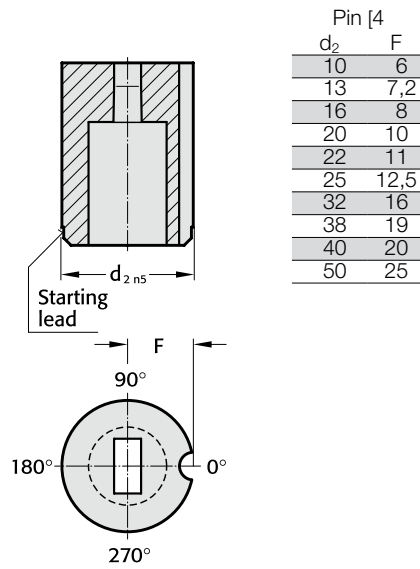

Anti-rotation element 3 (3)

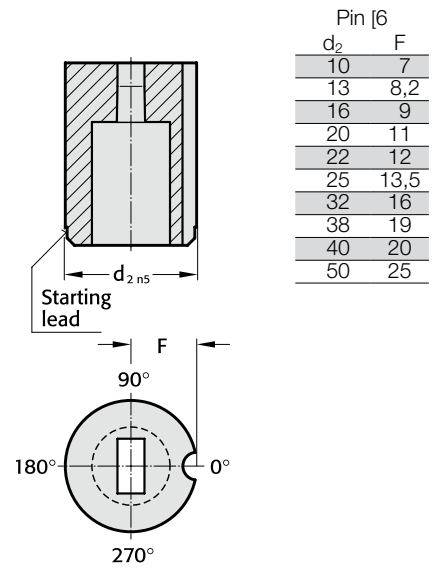

Anti-rotation element 4 (4)

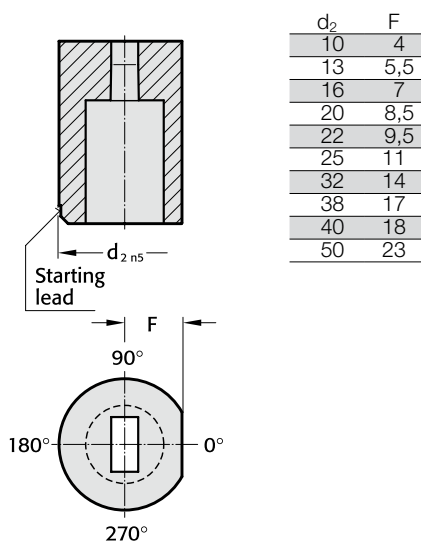

Anti-rotation element 5 (5)

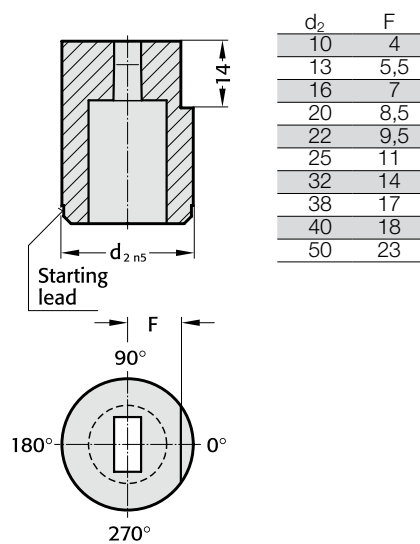

Anti-rotation element 6 (6)

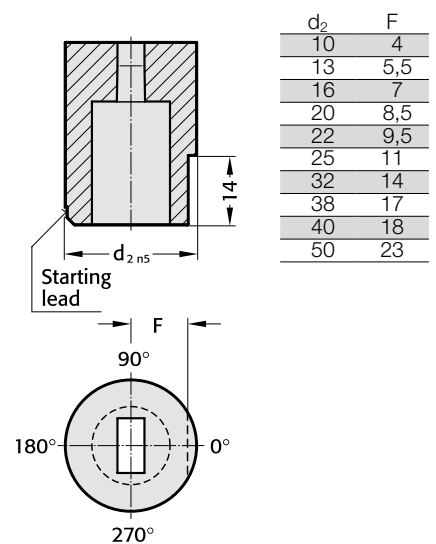

MATRIX WITH SHOULDER, BLANK, ISO 8977

2607.

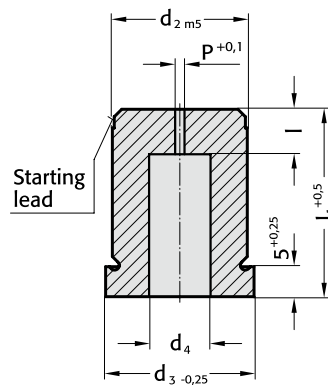

2607. Matrix with shoulder, blank, ISO 8977

d ₂ / Order No	d ₃	d ₄	P	l / Order No	l ₁ / (Order Code character)	16 (B)	20 (C)	22 (D)	25 (E)	28 (F)	30 (G)	32 (H)	35 (J)
5 / (1)	8	2.8	0.8	2 (1)		●	●	●	●	●	●	●	●
6 / (2)	9	3.5	1	3 (2)		●	●	●	●	●	●	●	●
8 / (3)	11	4	1	4 (3)		●	●	●	●	●	●	●	●
10 / (4)	13	5.8	1	4 (3) 8 (6)		●	●	●	●	●	●	●	●
13 / (5)	16	8	1.2	5 (4) 8 (6)			●	●	●	●	●	●	●
16 / (6)	19	9.5	1.2	5 (4) 8 (6)			●	●	●	●	●	●	●
20 / (7)	23	12	1.5	8 (6) 12 (8)			●	●	●	●	●	●	●
22 / (8)	25	15	1.5	8 (6) 12 (8)			●	●	●	●	●	●	●
25 / (9)	28	17.3	1.5	8 (6) 12 (8)			●	●	●	●	●	●	●
32 / (10)	35	20.7	1.5	8 (6) 12 (8)			●	●	●	●	●	●	●
38 / (11)	41	27.7	1.5	8 (6) 12 (8)			●	●	●	●	●	●	●
40 / (12)	43	27.7	1.5	8 (6) 12 (8)			●	●	●	●	●	●	●
50 / (14)	53	37	1.5	8 (6) 12 (8)			●	●	●	●	●	●	●

Ordering Code (example):

2607.11E6

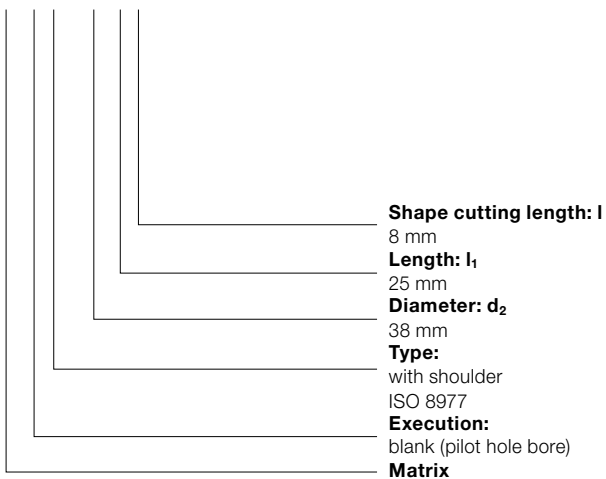

Order No
 = (6)
Order Code character
 = (E)
Order No
 = (11)
Order No
 = (7)
Order No
 = (0)
Matrix
 = 26

Material:

HSS
 Hardness 62 ± 2 HRC

Execution:

Diameter d₂, starting lead and face surfaces ground.
 Diameter P is a bored pilot hole for wire EDM.
 Special dimensions on request.

MATRIX WITH SHOULDER, ROUND, ISO 8977



2617.

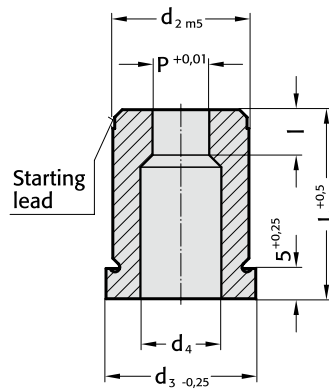

2617. Matrix with shoulder, round, ISO 8977

d ₂ / Order No	d ₃	d ₄	P	l / Order No	l ₁ / (Order Code character)	16 (B)	20 (C)	22 (D)	25 (E)	28 (F)	30 (G)	32 (H)	35 (J)
5 / (1)	8	2.8	1 - 2,4	2 (1)		●	●	●	●	●	●	●	●
6 / (2)	9	3.5	1,6 - 3	3 (2)		●	●	●	●	●	●	●	●
8 / (3)	11	4	2 - 3,5	4 (3)		●	●	●	●	●	●	●	●
10 / (4)	13	5.8	2,5 - 5	4 (3) 8 (6)		●	●	●	●	●	●	●	●
13 / (5)	16	8	4 - 7	5 (4) 8 (6)			●	●	●	●	●	●	●
16 / (6)	19	9.5	6 - 9	5 (4) 8 (6)			●	●	●	●	●	●	●
20 / (7)	23	12	8 - 11	8 (6) 12 (8)			●	●	●	●	●	●	●
22 / (8)	25	15	9 - 14	8 (6) 12 (8)			●	●	●	●	●	●	●
25 / (9)	28	17.3	10,7 - 16	8 (6) 12 (8)			●	●	●	●	●	●	●
32 / (10)	35	20.7	15 - 20	8 (6) 12 (8)			●	●	●	●	●	●	●
38 / (11)	41	27.7	19 - 27	8 (6) 12 (8)			●	●	●	●	●	●	●
40 / (12)	43	27.7	19 - 27	8 (6) 12 (8)			●	●	●	●	●	●	●
50 / (14)	53	37	26 - 36	8 (6) 12 (8)			●	●	●	●	●	●	●

Material:

HSS
Hardness 62 ± 2 HRC

Execution:

Diameter d₂, starting lead and face surfaces ground.
Special dimensions on request.

Ordering Code (example): without anti-rotation element

2617.10F8.1510

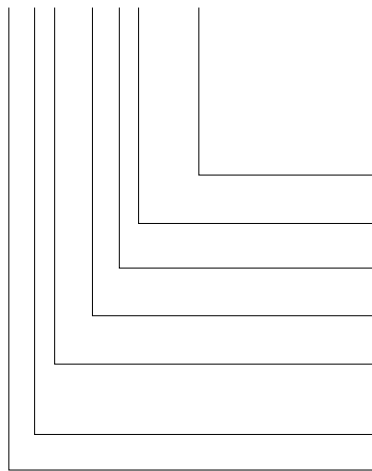

Shape: round
P = ø15,1 mm
Shape cutting length: l
12 mm
Length: l₁
28 mm
Diameter: d₂
32 mm
Type:
with shoulder
ISO 8977
Execution:
round
Matrix

= 1510
Order No
= (8)
Order Code character
= (F)
Order No
= (10)
Order No
= (7)
Order No
= (1)
= 26

MATRIXES WITH SHOULDER, CYLINDRICAL, ISO 8977, ANTI-ROTATION ELEMENTS

Anti-rotation element 1 (1)

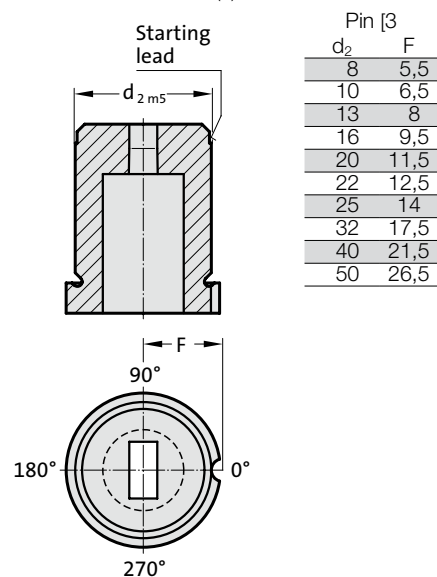

Anti-rotation element 2 (2)

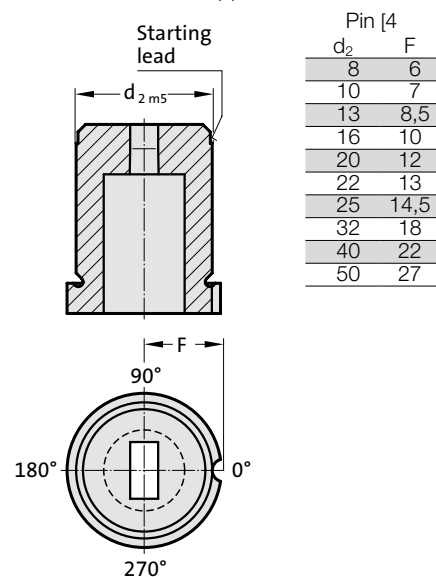

Anti-rotation element 3 (3)

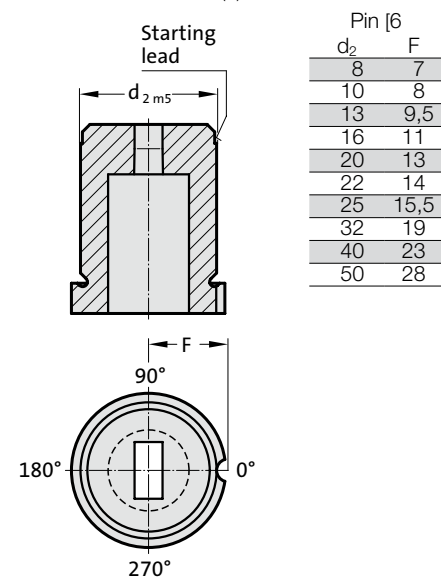

Anti-rotation element 4 (4)

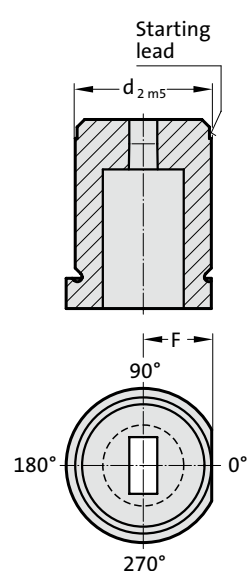

Ordering Code (example): with anti-rotation element from $d_2 \geq 8$ mm

2617.10F8.1510.A4

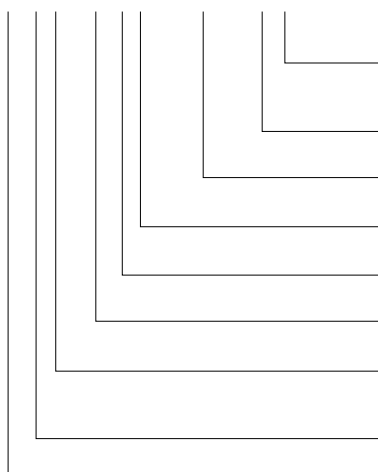

Anti-rotation element:
Polished surface
(continuous)
Angle:
0°
Shape: round
P = $\phi 15,1$ mm
Shape cutting length: l
12 mm
Length: l₁
28 mm
Diameter: d₂
32 mm
Type:
with shoulder
ISO 8977
Execution:
round
Matrix

Order No
= (4)
Order Code character
= (A)
= 1510
Order No
= (8)
Order Code character
= (F)
Order No
= (10)
Order No
= (7)
Order No
= (1)
= 26

MATRIX WITH SHOULDER, SQUARE, ISO 8977



2627.

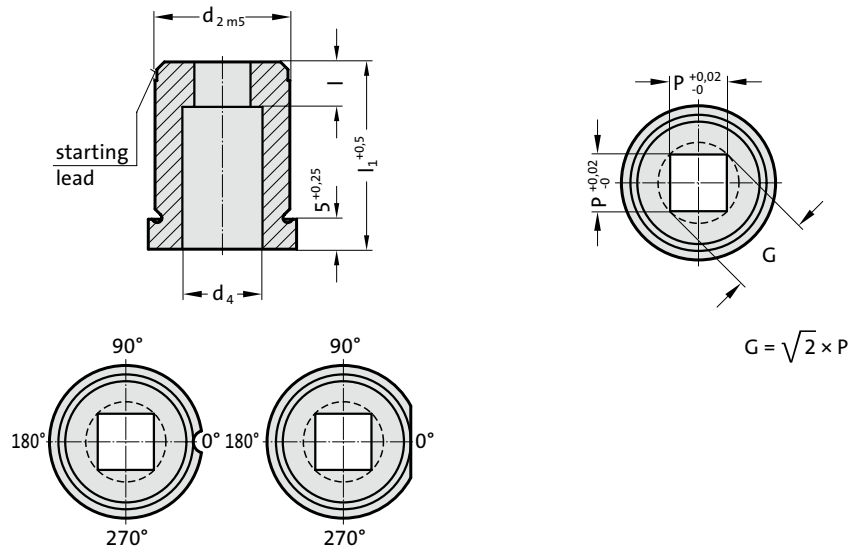

2627. Matrix with shoulder, square, ISO 8977

d ₂ / Order No	d ₃	d ₄	P _{min}	G _{max}	l / Order No	l ₁ / (Order Code character)	16 (B)	20 (C)	22 (D)	25 (E)	28 (F)	30 (G)	32 (H)	35 (J)
8 / (3)	11	4	1.2	3.5	4 (3)		●	●	●	●	●	●	●	●
10 / (4)	13	5.8	1.2	5	4 (3) 8 (6)		●	●	●	●	●	●	●	●
13 / (5)	16	8	2	7	5 (4) 8 (6)		●	●	●	●	●	●	●	●
16 / (6)	19	9.5	2.4	9	5 (4) 8 (6)		●	●	●	●	●	●	●	●
20 / (7)	23	12	3.2	11	8 (6) 12 (8)		●	●	●	●	●	●	●	●
22 / (8)	25	15	4	14	8 (6) 12 (8)		●	●	●	●	●	●	●	●
25 / (9)	28	17.3	4.8	16	8 (6) 12 (8)		●	●	●	●	●	●	●	●
32 / (10)	35	20.7	5.5	20	8 (6) 12 (8)		●	●	●	●	●	●	●	●
38 / (11)	41	27.7	6.4	27	8 (6) 12 (8)		●	●	●	●	●	●	●	●
40 / (12)	43	27.7	6.4	27	8 (6) 12 (8)		●	●	●	●	●	●	●	●
50 / (14)	53	37	6.4	36	8 (6) 12 (8)		●	●	●	●	●	●	●	●

Material:

HSS

Hardness 62 ± 2 HRC

Execution:

Diameter d₂, starting lead and face surfaces ground.

Special dimensions on request.

Ordering Code (example): with anti-rotation element

2627.10F8.1350.A3

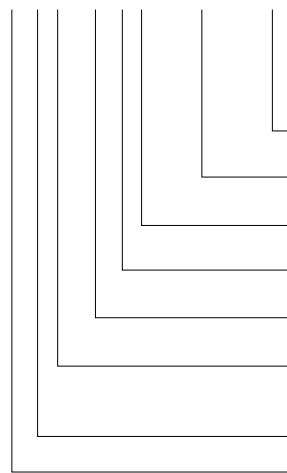

Anti-rotation element:

Pin Ø 6 mm

Angle:

0°

Shape: square, Length P

P = 13,5 mm

Shape cutting length: l

12 mm

Length: l₁

28 mm

Diameter: d₂

32 mm

Type:

with shoulder

ISO 8977

Execution:

square

Matrix

Order No

= (3)

Order Code character

= (A)

= 1350

Order No

= (8)

Order Code character

= (F)

Order No

= (10)

Order No

= (7)

Order No

= (2)

= 26

MATRIXES WITH SHOULDER, CYLINDRICAL, ISO 8977, ANTI-ROTATION ELEMENTS

Anti-rotation element 1 (1)

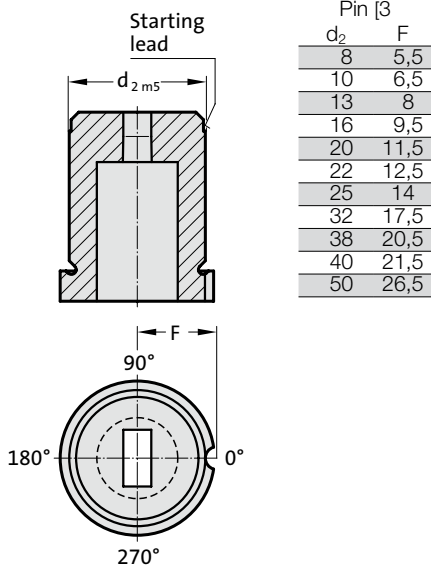

Anti-rotation element 2 (2)

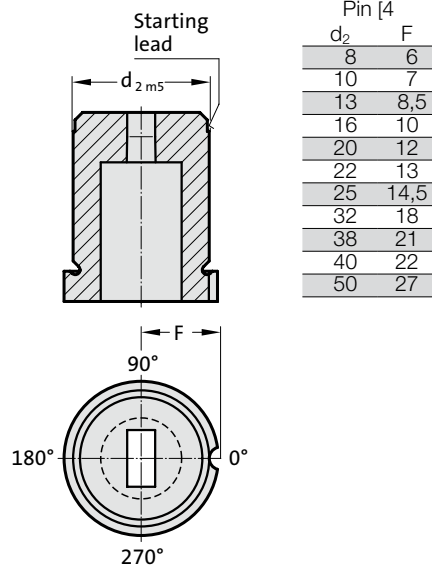

Anti-rotation element 3 (3)

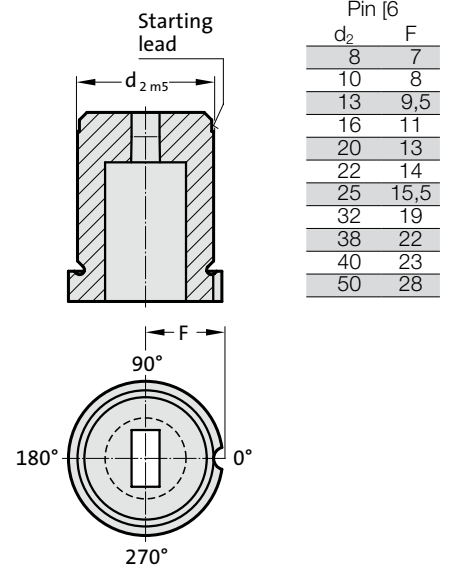

Anti-rotation element 4 (4)

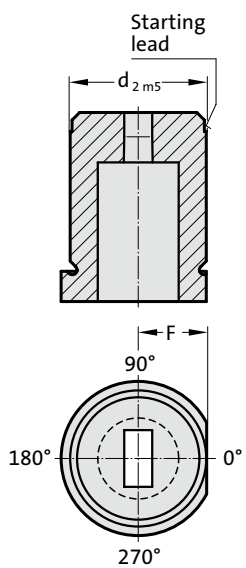

MATRIX WITH SHOULDER, RECTANGULAR, ISO 8977



2637.

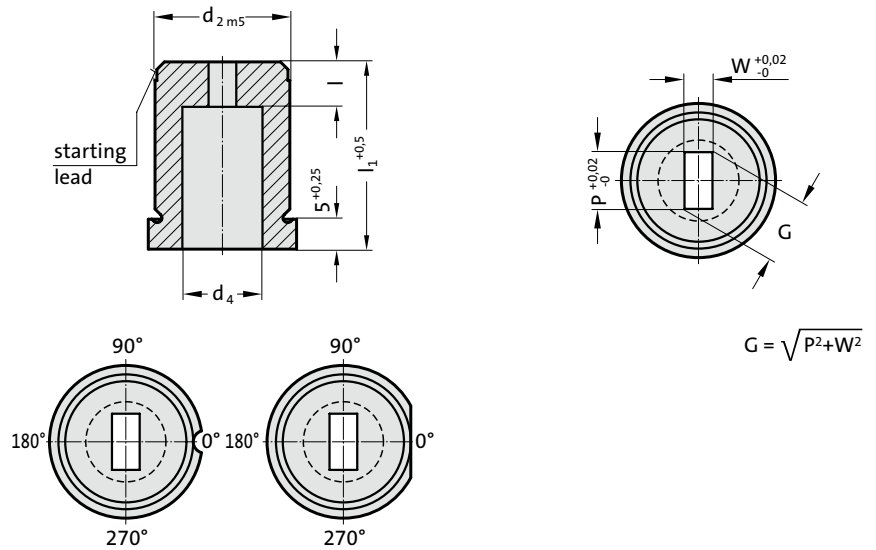

2637. Matrix with shoulder, rectangular, ISO 8977

d ₂ / Order No	d ₃	d ₄	W _{min}	G _{max}	l / Order No	l ₁ / (Order Code character)	16 (B)	20 (C)	22 (D)	25 (E)	28 (F)	30 (G)	32 (H)	35 (J)
8 / (3)	11	4	1.2	3.5	4 (3)		●	●	●	●	●	●	●	●
10 / (4)	13	5.8	1.2	5	4 (3) 8 (6)		●	●	●	●	●	●	●	●
13 / (5)	16	8	2	7	5 (4) 8 (6)		●	●	●	●	●	●	●	●
16 / (6)	19	9.5	2.4	9	5 (4) 8 (6)		●	●	●	●	●	●	●	●
20 / (7)	23	12	3.2	11	8 (6) 12 (8)		●	●	●	●	●	●	●	●
22 / (8)	25	15	4	14	8 (6) 12 (8)		●	●	●	●	●	●	●	●
25 / (9)	28	17.3	4.8	16	8 (6) 12 (8)		●	●	●	●	●	●	●	●
32 / (10)	35	20.7	5.5	20	8 (6) 12 (8)		●	●	●	●	●	●	●	●
38 / (11)	41	27.7	6.4	27	8 (6) 12 (8)		●	●	●	●	●	●	●	●
40 / (12)	43	27.7	6.4	27	8 (6) 12 (8)		●	●	●	●	●	●	●	●
50 / (14)	53	37	6.4	36	8 (6) 12 (8)		●	●	●	●	●	●	●	●

Material:

HSS

Hardness 62 ± 2 HRC

Execution:

Diameter d₂, starting lead and face surfaces ground.

Special dimensions on request.

Ordering Code (example): with anti-rotation element

2637.10F8.1350.0650.B2

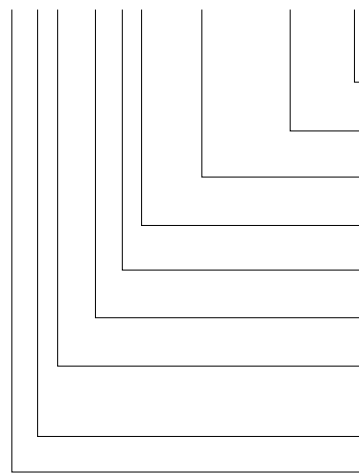

Anti-rotation element:

Pin Ø 4 mm

Angle:

90°

Shape: rectangular, Width W

W = 6,5 mm

Shape: rectangular, Length P

P = 13,5 mm

Shape cutting length: l

12 mm

Length: l₁

28 mm

Diameter: d₂

32 mm

Type:

with shoulder

ISO 8977

Execution:

rectangular

Matrix

Order No

= (2)

Order Code character

= (B)

= 0650

= 1350

Order No

= (8)

Order Code character

= (F)

Order No

= (10)

Order No

= (7)

Order No

= (3)

= 26

MATRIXES WITH SHOULDER, CYLINDRICAL, ISO 8977, ANTI-ROTATION ELEMENTS

Anti-rotation element 1 (1)

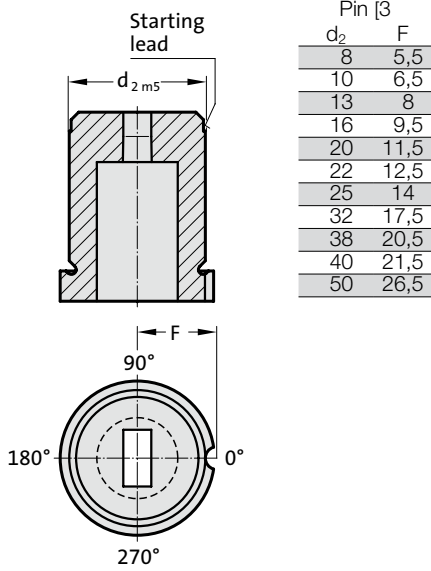

Anti-rotation element 2 (2)

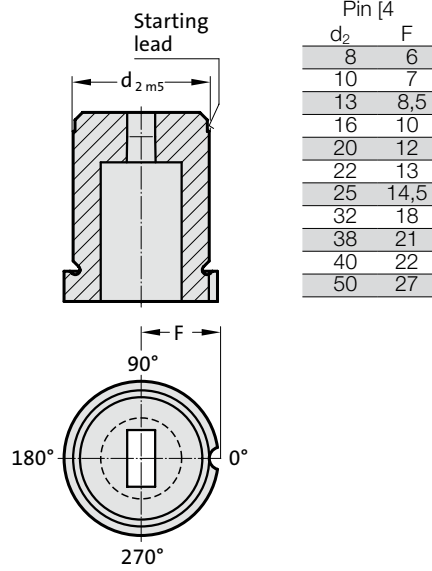

Anti-rotation element 3 (3)

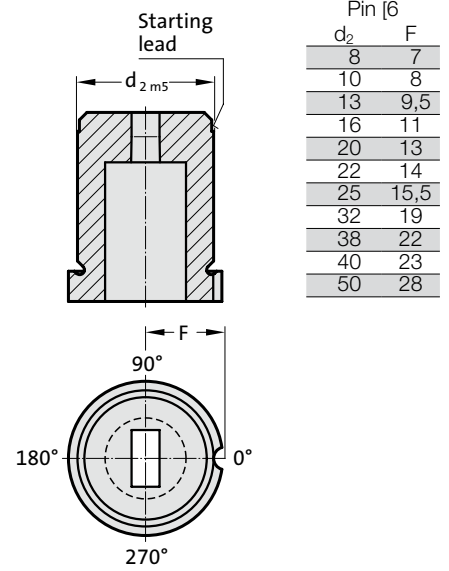

Anti-rotation element 4 (4)

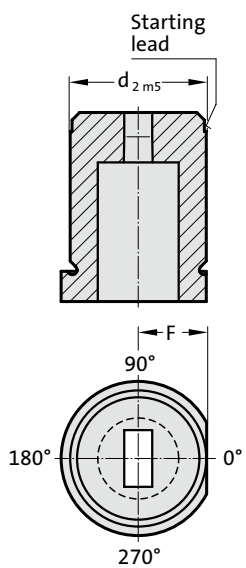

MATRIX WITH SHOULDER, SLOT, ISO 8977



2647.

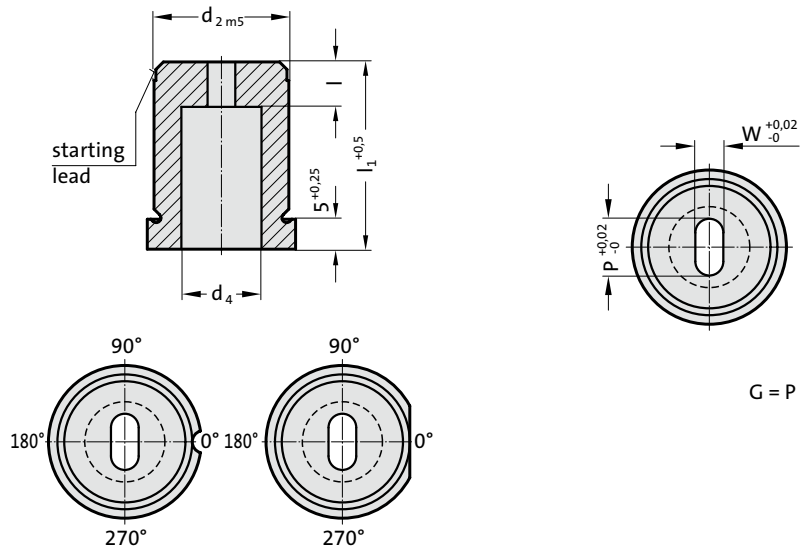

2647. Matrix with shoulder, slot, ISO 8977

d ₂ / Order No	d ₃	d ₄	W _{min}	G _{max}	l / Order No	l ₁ / (Order Code character)	16 (B)	20 (C)	22 (D)	25 (E)	28 (F)	30 (G)	32 (H)	35 (J)
8 / (3)	11	4	1.2	3.5	4 (3)		●	●	●	●	●	●	●	●
10 / (4)	13	5.8	1.2	5	4 (3) 8 (6)		●	●	●	●	●	●	●	●
13 / (5)	16	8	2	7	5 (4) 8 (6)		●	●	●	●	●	●	●	●
16 / (6)	19	9.5	2.4	9	5 (4) 8 (6)		●	●	●	●	●	●	●	●
20 / (7)	23	12	3.2	11	8 (6) 12 (8)		●	●	●	●	●	●	●	●
22 / (8)	25	15	4	14	8 (6) 12 (8)		●	●	●	●	●	●	●	●
25 / (9)	28	17.3	4.8	16	8 (6) 12 (8)		●	●	●	●	●	●	●	●
32 / (10)	35	20.7	5.5	20	8 (6) 12 (8)		●	●	●	●	●	●	●	●
38 / (11)	41	27.7	6.4	27	8 (6) 12 (8)		●	●	●	●	●	●	●	●
40 / (12)	43	27.7	6.4	27	8 (6) 12 (8)		●	●	●	●	●	●	●	●
50 / (14)	53	37	6.4	36	8 (6) 12 (8)		●	●	●	●	●	●	●	●

Material:

HSS

Hardness 62 ± 2 HRC

Execution:

Diameter d₂, starting lead and face surfaces ground.

Special dimensions on request.

Ordering Code (example): with anti-rotation element

2647.10F8.1350.0650.A3

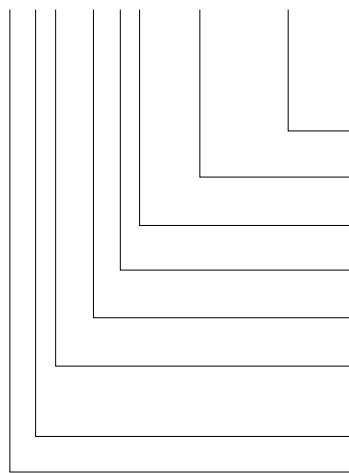

Anti-rotation element:

Pin Ø 6 mm

Angle:

0°

Shape: slot, Width W

W = 6,5 mm

Shape: slot, Length P

P = 13,5 mm

Shape cutting length: l

12 mm

Length: l₁

28 mm

Diameter: d₂

32 mm

Type:

with shoulder
ISO 8977

Execution:

slot

Matrix

Order No

= (3)

Order Code character

= (A)

= 0650

= 1350

Order No

= (8)

Order Code character

= (F)

Order No

= (10)

Order No

= (7)

Order No

= (4)

= 26

MATRIXES WITH SHOULDER, CYLINDRICAL, ISO 8977, ANTI-ROTATION ELEMENTS

Anti-rotation element 1 (1)

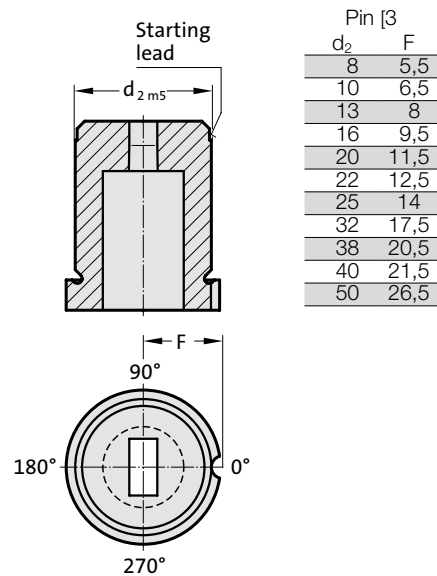

Anti-rotation element 2 (2)

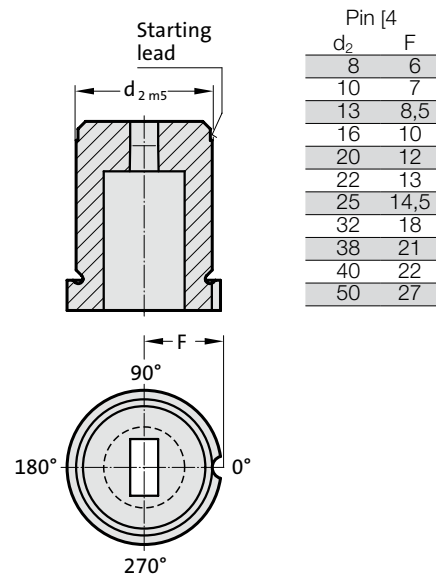

Anti-rotation element 3 (3)

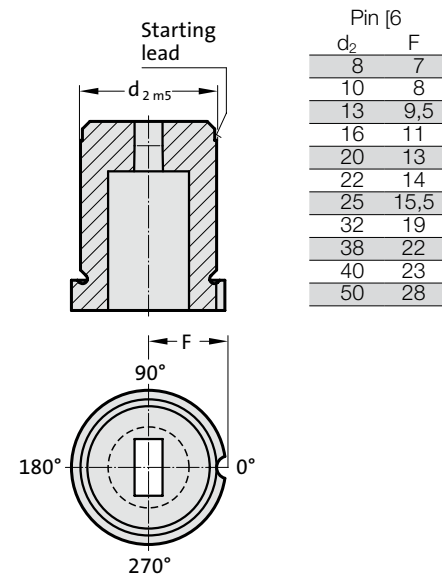

Anti-rotation element 4 (4)

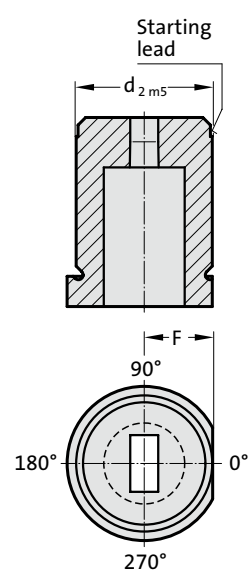

MATRIX WITH SHOULDER, RECTANGLE WITH RADIUSSED CORNERS, ISO 8977



2657.

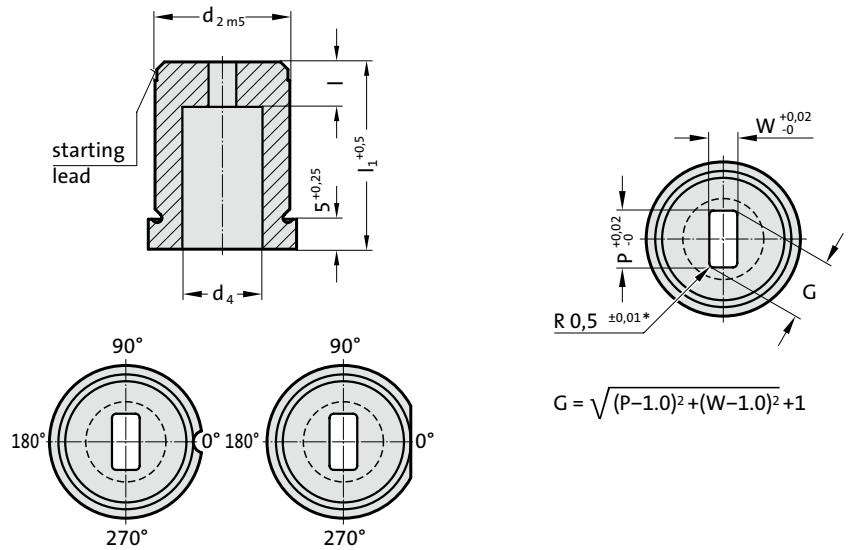

2657. Matrix with shoulder, rectangle with radiused corners, ISO 8977

d ₂ / Order No	d ₃	d ₄	W _{min}	G _{max}	l / Order No	l ₁ / (Order Code character)	16 (B)	20 (C)	22 (D)	25 (E)	28 (F)	30 (G)	32 (H)	35 (J)
8 / (3)	11	4	1.2	3.5	4 (3)		●	●	●	●	●	●	●	●
10 / (4)	13	5.8	1.2	5	4 (3) 8 (6)		●	●	●	●	●	●	●	●
13 / (5)	16	8	2	7	5 (4) 8 (6)		●	●	●	●	●	●	●	●
16 / (6)	19	9.5	2.4	9	5 (4) 8 (6)		●	●	●	●	●	●	●	●
20 / (7)	23	12	3.2	11	8 (6) 12 (8)		●	●	●	●	●	●	●	●
22 / (8)	25	15	4	14	8 (6) 12 (8)		●	●	●	●	●	●	●	●
25 / (9)	28	17.3	4.8	16	8 (6) 12 (8)		●	●	●	●	●	●	●	●
32 / (10)	35	20.7	5.5	20	8 (6) 12 (8)		●	●	●	●	●	●	●	●
38 / (11)	41	27.7	6.4	27	8 (6) 12 (8)		●	●	●	●	●	●	●	●
40 / (12)	43	27.7	6.4	27	8 (6) 12 (8)		●	●	●	●	●	●	●	●
50 / (14)	53	37	6.4	36	8 (6) 12 (8)		●	●	●	●	●	●	●	●

Material:

HSS

Hardness 62 ± 2 HRC

Execution:

Diameter d₂, starting lead and face surfaces ground.

Special dimensions on request.

* For other radius options, see standardised special shapes.

Ordering Code (example): with anti-rotation element

2657.10F8.1350.0650.A1

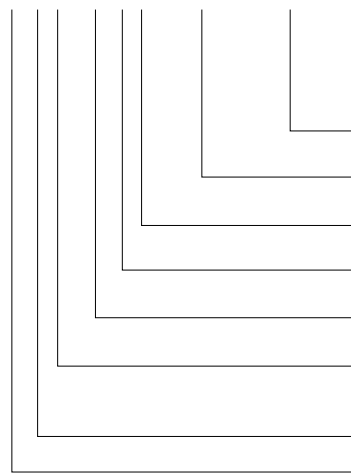

Anti-rotation element:

Pin Ø 3 mm

Angle:

0°

Shape: rectangle with radiused corners, Width W

W = 6,5 mm

Shape: rectangle with radiused corners, Length P

P = 13,5 mm

Shape cutting length: l

12 mm

Length: l₁

28 mm

Diameter: d₂

32 mm

Type:

with shoulder

ISO 8977

Execution:

rectangle with radiused corners

Matrix

Order No

= (3)

Order Code character

= (A)

Order Code character

= 0650

Order Code character

= 1350

Order No

= (8)

Order Code character

= (F)

Order No

= (10)

Order No

= (7)

Order No

= (5)

= 26

MATRIXES WITH SHOULDER, CYLINDRICAL, ISO 8977, ANTI-ROTATION ELEMENTS

Anti-rotation element 1 (1)

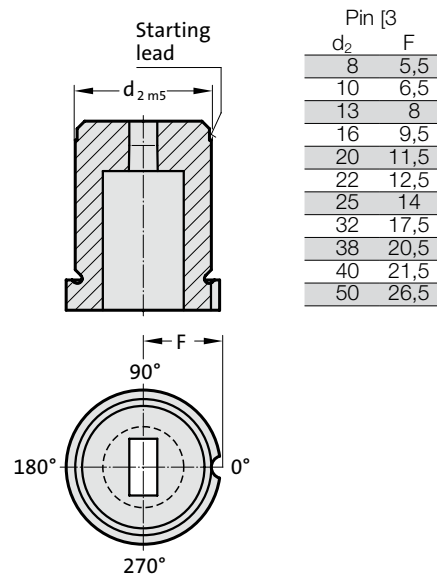

Anti-rotation element 2 (2)

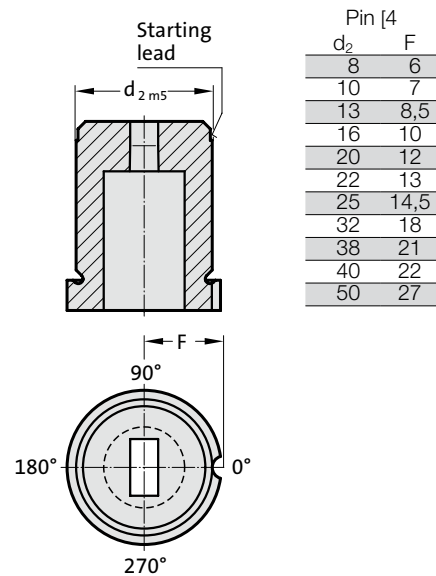

Anti-rotation element 3 (3)

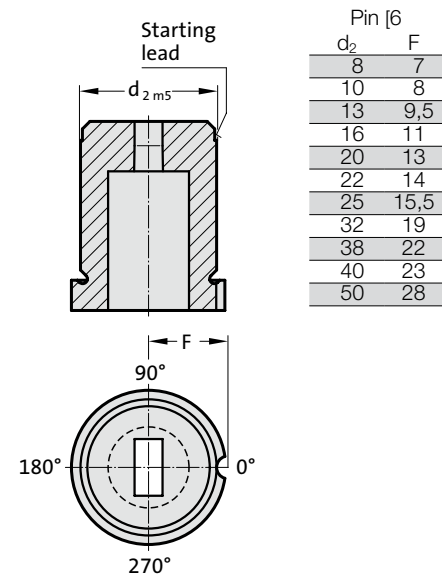

Anti-rotation element 4 (4)

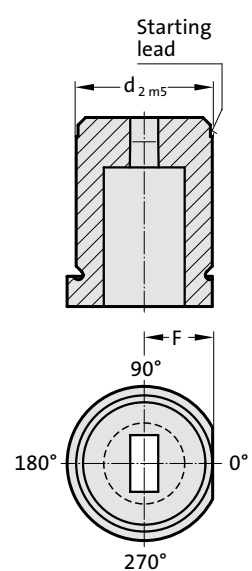

Matrix without shoulder, blank, Automotive Standard



2605.

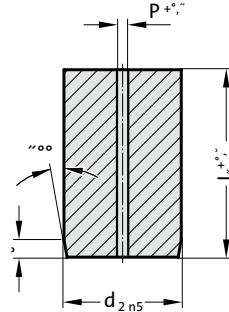

2605. Matrix without shoulder, blank, Automotive Standard

d ₂ / (Order No)	P	l ₁ / (Order Code character)	13 (A)	16 (B)	20 (C)	22 (D)	25 (E)	28 (F)	30 (G)	32 (H)	35 (J)	40 (K)
10 / (4)	0.8		●	●	●	●	●	●	●	●	●	●
13 / (5)	0.8		●	●	●	●	●	●	●	●	●	●
16 / (6)	1.5				●	●	●	●	●	●	●	●
20 / (7)	1.5				●	●	●	●	●	●	●	●
22 / (8)	1.5				●	●	●	●	●	●	●	●
25 / (9)	1.5				●	●	●	●	●	●	●	●
32 / (10)	1.5				●	●	●	●	●	●	●	●
38 / (11)	1.5				●	●	●	●	●	●	●	●
40 / (12)	1.5					●	●	●	●	●	●	●
45 / (13)	1.5					●	●	●	●	●	●	●
50 / (14)	1.5					●	●	●	●	●	●	●
56 / (15)	1.5					●	●	●	●	●	●	●
63 / (16)	1.5					●	●	●	●	●	●	●
71 / (17)	1.5					●	●	●	●	●	●	●
76 / (18)	1.5					●	●	●	●	●	●	●
85 / (19)	1.5					●	●	●	●	●	●	●
90 / (20)	1.5					●	●	●	●	●	●	●
100 / (21)	1.5						●	●	●	●	●	●

Material:

HSS
Hardness 62 ± 2 HRC

Execution:

Diameter d₂ and face surfaces ground.
Diameter P is a bored pilot hole for wire EDM.
Special dimensions on request.

Ordering example:

2 6 0 5 . 10 F

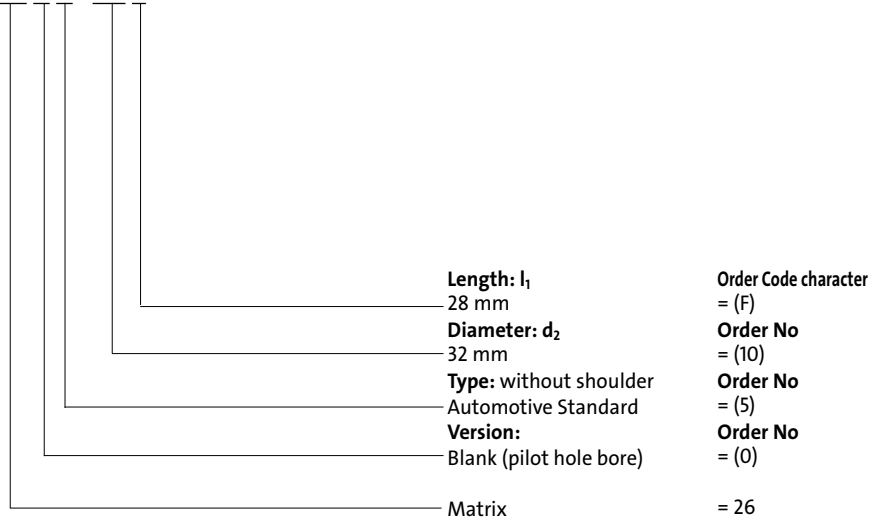



MATRIX WITHOUT SHOULDER, ROUND, AUTOMOTIVE STANDARD



2615.

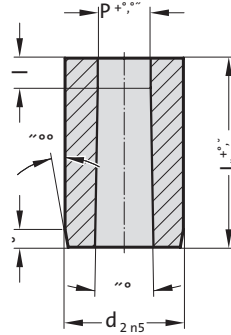

2615. Matrix without shoulder, round, Automotive Standard

d ₂ / Order No	P	l ₁ / (Order Code character)	13 (A)	16 (B)	20 (C)	22 (D)	25 (E)	28 (F)	30 (G)	32 (H)	35 (J)	40 (K)
10 / (4)	1,6 - 6,8		●	●	●	●	●	●	●	●	●	
13 / (5)	3 - 8,8		●	●	●	●	●	●	●	●	●	
16 / (6)	7,4 - 10,8				●	●	●	●	●	●	●	
20 / (7)	9,5 - 13,6				●	●	●	●	●	●	●	
22 / (8)	10,5 - 15				●	●	●	●	●	●	●	
25 / (9)	12 - 17				●	●	●	●	●	●	●	
32 / (10)	16 - 22				●	●	●	●	●	●	●	
38 / (11)	18 - 27				●	●	●	●	●	●	●	●
40 / (12)	18 - 27					●	●	●	●	●	●	●
45 / (13)	18 - 35					●	●	●	●	●	●	●
50 / (14)	18 - 40					●	●	●	●	●	●	●
56 / (15)	18 - 45					●	●	●	●	●	●	●
63 / (16)	18 - 50					●	●	●	●	●	●	●
71 / (17)	18 - 56					●	●	●	●	●	●	●
76 / (18)	25 - 60						●	●	●	●	●	●
85 / (19)	25 - 66						●	●	●	●	●	●
90 / (20)	32 - 70						●	●	●	●	●	●
100 / (21)	32 - 78						●	●	●	●	●	●

Material:

HSS
Hardness 62 ± 2 HRC

Execution:

Diameter d₂ and end faces ground.
Special dimensions on request.

Ordering Code (example): without / with anti-rotation element

2 615 . 10 F 8 . 2190 / . A 3

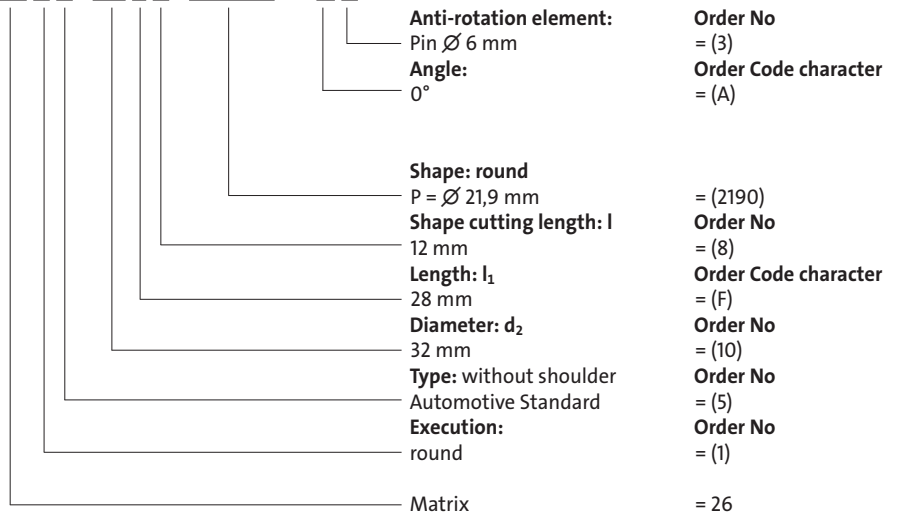

MATRIX WITHOUT SHOULDER, SQUARE, AUTOMOTIVE STANDARD

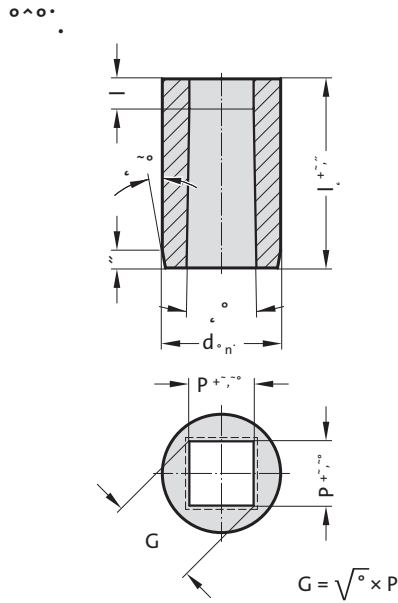

2625. Matrix without shoulder, square, Automotive Standard

d_2 / Order No	P_{min}	C_{max}	l / Order No	l_1 / (Order Code character)	13 (A)	16 (B)	20 (C)	22 (D)	25 (E)	28 (F)	30 (G)	32 (H)	35 (J)	40 (K)
10 / (4)	1.3	6.8	3 (2) 4 (3) 5 (4)		●	●	●	●	●	●	●	●	●	
13 / (5)	1.9	8.8	3 (2) 5 (4) 8 (6)		●	●	●	●	●	●	●	●	●	
16 / (6)	1.9	10.8	3 (2) 5 (4) 8 (6)				●	●	●	●	●	●	●	
20 / (7)	1.9	13.6	3 (2) 6 (5) 10 (7)				●	●	●	●	●	●	●	
22 / (8)	1.9	15	3 (2) 6 (5) 10 (7)				●	●	●	●	●	●	●	
25 / (9)	1.9	17	3 (2) 6 (5) 10 (7)				●	●	●	●	●	●	●	
32 / (10)	1.9	22	3 (2) 6 (5) 12 (8)				●	●	●	●	●	●	●	
38 / (11)	1.9	27	3 (2) 8 (6) 12 (8)				●	●	●	●	●	●	●	●
40 / (12)	1.9	27	3 (2) 8 (6) 12 (8)					●	●	●	●	●	●	●
45 / (13)	2.4	35	3 (2) 8 (6) 12 (8)					●	●	●	●	●	●	●
50 / (14)	4	40	3 (2) 8 (6) 12 (8)					●	●	●	●	●	●	●
56 / (15)	4	45	3 (2) 8 (6) 12 (8)					●	●	●	●	●	●	●
63 / (16)	4	50	3 (2) 8 (6) 12 (8)					●	●	●	●	●	●	●
71 / (17)	4	56	3 (2) 8 (6) 12 (8)					●	●	●	●	●	●	●
76 / (18)	5.6	60	3 (2) 8 (6) 12 (8)					●	●	●	●	●	●	●
85 / (19)	5.6	66	3 (2) 8 (6) 12 (8)					●	●	●	●	●	●	●
90 / (20)	5.6	70	3 (2) 8 (6) 12 (8)					●	●	●	●	●	●	●
100 / (21)	5.6	78	3 (2) 8 (6) 12 (8)					●	●	●	●	●	●	●

Material:

HSS
Hardness 62 ± 2 HRC

Execution:

Diameter d_2 and end faces ground.
Special dimensions on request.

Ordering Code (example): with anti-rotation element

2 6 2 5 . 10 F 8 . 1350 . A 3

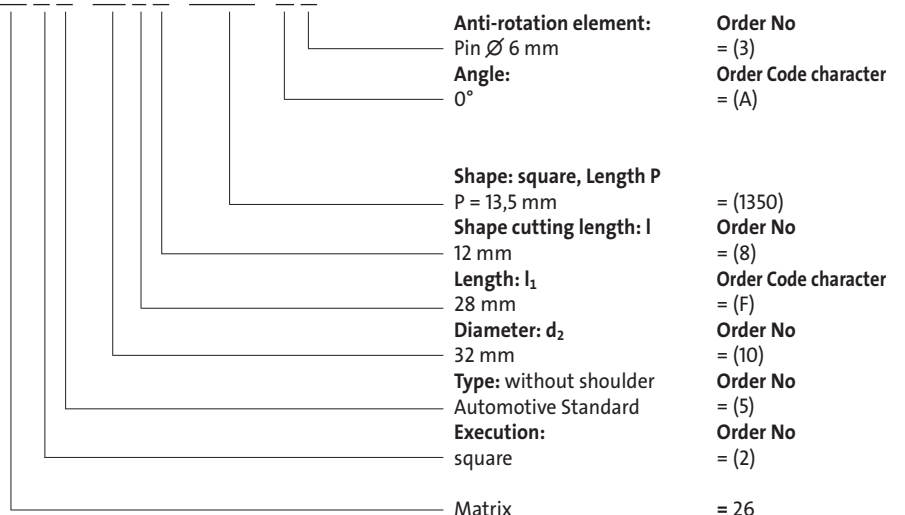

MATRIX WITHOUT SHOULDER, RECTANGULAR, AUTOMOTIVE STANDARD



2635.

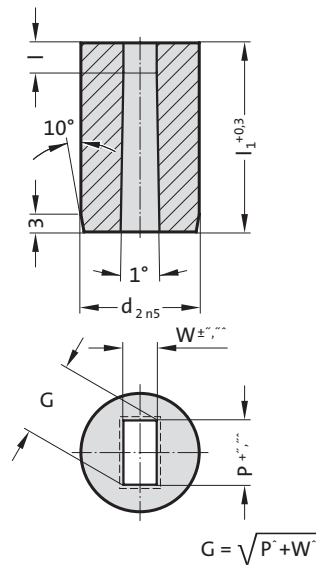

2635. Matrix without shoulder, rectangular, Automotive Standard

d ₂ / Order No	W _{min}	C _{max}	l / Order No	l ₁ / (Order Code character)	13 (A)	16 (B)	20 (C)	22 (D)	25 (E)	28 (F)	30 (G)	32 (H)	35 (J)	40 (K)
10 / (4)	1.3	6.8	3 (2) 4 (3) 5 (4)		●	●	●	●	●	●	●	●	●	●
13 / (5)	1.9	8.8	3 (2) 5 (4) 8 (6)		●	●	●	●	●	●	●	●	●	●
16 / (6)	1.9	10.8	3 (2) 5 (4) 8 (6)				●	●	●	●	●	●	●	●
20 / (7)	1.9	13.6	3 (2) 6				●	●	●	●	●	●	●	●
22 / (8)	1.9	15	3 (2) 6 (5) 10 (7)				●	●	●	●	●	●	●	●
25 / (9)	1.9	17	3 (2) 6 (5) 10 (7)				●	●	●	●	●	●	●	●
32 / (10)	1.9	22	3 (2) 6 (5) 12 (8)				●	●	●	●	●	●	●	●
38 / (11)	1.9	27	3 (2) 8 (6) 12 (8)				●	●	●	●	●	●	●	●
40 / (12)	1.9	27	3 (2) 8 (6) 12 (8)					●	●	●	●	●	●	●
45 / (13)	2.4	35	3 (2) 8 (6) 12 (8)					●	●	●	●	●	●	●
50 / (14)	4	40	3 (2) 8 (6) 12 (8)					●	●	●	●	●	●	●
56 / (15)	4	45	3 (2) 8 (6) 12 (8)					●	●	●	●	●	●	●
63 / (16)	4	50	3 (2) 8 (6) 12 (8)					●	●	●	●	●	●	●
71 / (17)	4	56	3 (2) 8 (6) 12 (8)					●	●	●	●	●	●	●
76 / (18)	5.6	60	3 (2) 8 (6) 12 (8)					●	●	●	●	●	●	●
85 / (19)	5.6	66	3 (2) 8 (6) 12 (8)					●	●	●	●	●	●	●
90 / (20)	5.6	70	3 (2) 8 (6) 12 (8)					●	●	●	●	●	●	●
100 / (21)	5.6	78	3 (2) 8 (6) 12 (8)					●	●	●	●	●	●	●

Material:

HSS
Hardness 62 ± 2 HRC

Execution:

Diameter d₂ and end faces ground.
Special dimensions on request.

Ordering Code (example): with anti-rotation element

2635.10F8.1350.0650.A3

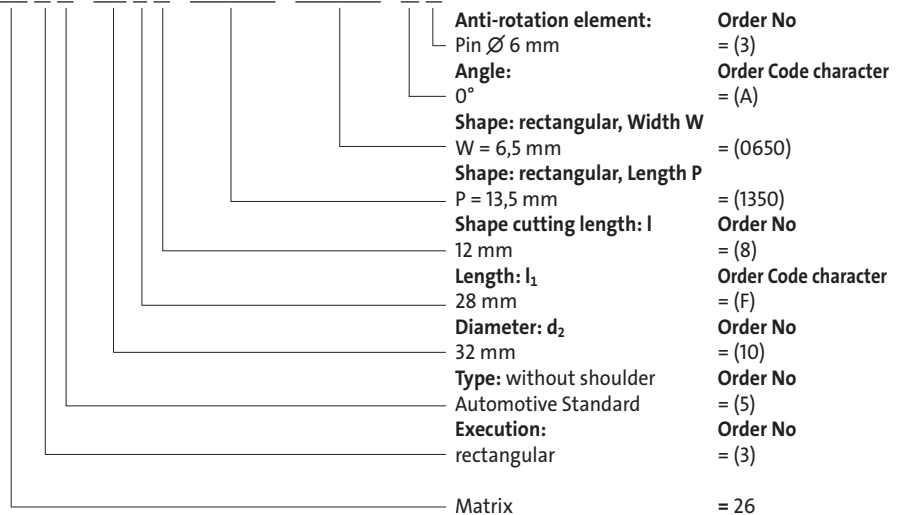

MATRIX WITHOUT SHOULDER, SLOT, AUTOMOTIVE STANDARD



2645.

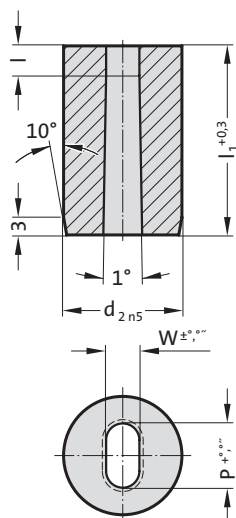

G = P

2645. Matrix without shoulder, slot, Automotive Standard

d ₂ / Order No	W _{min}	G _{max}	l / Order No	l ₁ / (Order Code character)	13 (A)	16 (B)	20 (C)	22 (D)	25 (E)	28 (F)	30 (G)	32 (H)	35 (J)	40 (K)
10 / (4)	1.3	6.8	3 (2) 4 (3) 5 (4)		●	●	●	●	●	●	●	●	●	●
13 / (5)	1.9	8.8	3 (2) 5 (4) 8 (6)		●	●	●	●	●	●	●	●	●	●
16 / (6)	1.9	10.8	3 (2) 5 (4) 8 (6)				●	●	●	●	●	●	●	●
20 / (7)	1.9	13.6	3 (2) 6				●	●	●	●	●	●	●	●
22 / (8)	1.9	15	3 (2) 6 (5) 10 (7)				●	●	●	●	●	●	●	●
25 / (9)	1.9	17	3 (2) 6 (5) 10 (7)				●	●	●	●	●	●	●	●
32 / (10)	1.9	22	3 (2) 6 (5) 12 (8)				●	●	●	●	●	●	●	●
38 / (11)	1.9	27	3 (2) 8 (6) 12 (8)				●	●	●	●	●	●	●	●
40 / (12)	1.9	27	3 (2) 8 (6) 12 (8)					●	●	●	●	●	●	●
45 / (13)	2.4	35	3 (2) 8 (6) 12 (8)					●	●	●	●	●	●	●
50 / (14)	4	40	3 (2) 8 (6) 12 (8)					●	●	●	●	●	●	●
56 / (15)	4	45	3 (2) 8 (6) 12 (8)					●	●	●	●	●	●	●
63 / (16)	4	50	3 (2) 8 (6) 12 (8)					●	●	●	●	●	●	●
71 / (17)	4	56	3 (2) 8 (6) 12 (8)					●	●	●	●	●	●	●
76 / (18)	5.6	60	3 (2) 8 (6) 12 (8)					●	●	●	●	●	●	●
85 / (19)	5.6	66	3 (2) 8 (6) 12 (8)					●	●	●	●	●	●	●
90 / (20)	5.6	70	3 (2) 8 (6) 12 (8)					●	●	●	●	●	●	●
100 / (21)	5.6	78	3 (2) 8 (6) 12 (8)					●	●	●	●	●	●	●

Material:

HSS

Hardness 62 ± 2 HRC

Execution:

Diameter d₂ and end faces ground.

Special dimensions on request.

Ordering Code (example): with anti-rotation element

2645.10F8.1350.0650.A3

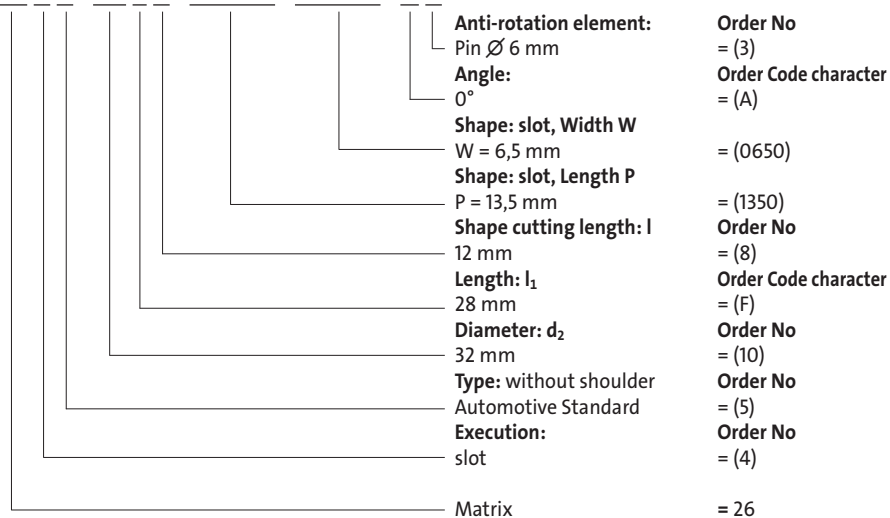

MATRIX WITHOUT SHOULDER, RECTANGLE WITH RADIUSED CORNERS, AUTOMOTIVE STANDARD



2655.

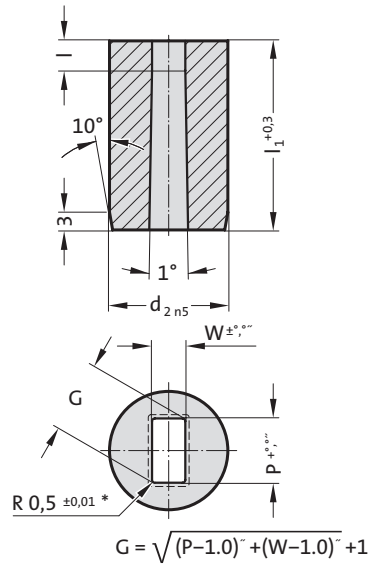

2655. Matrix without shoulder, rectangle with radiused corners, Automotive Standard

d ₂ / Order No	W _{min}	G _{max}	l / Order No	l ₁ / (Order Code character)	13 (A)	16 (B)	20 (C)	22 (D)	25 (E)	28 (F)	30 (G)	32 (H)	35 (J)	40 (K)
10 / (4)	1.3	6.8	3 (2) 4 (3) 5 (4)		●	●	●	●	●	●	●	●	●	●
13 / (5)	1.9	8.8	3 (2) 5 (4) 8 (6)		●	●	●	●	●	●	●	●	●	●
16 / (6)	1.9	10.8	3 (2) 5 (4) 8 (6)				●	●	●	●	●	●	●	●
20 / (7)	1.9	13.6	3 (2) 6				●	●	●	●	●	●	●	●
22 / (8)	1.9	15	3 (2) 6 (5) 10 (7)				●	●	●	●	●	●	●	●
25 / (9)	1.9	17	3 (2) 6 (5) 10 (7)				●	●	●	●	●	●	●	●
32 / (10)	1.9	22	3 (2) 6 (5) 12 (8)				●	●	●	●	●	●	●	●
38 / (11)	1.9	27	3 (2) 8 (6) 12 (8)				●	●	●	●	●	●	●	●
40 / (12)	1.9	27	3 (2) 8 (6) 12 (8)					●	●	●	●	●	●	●
45 / (13)	2.4	35	3 (2) 8 (6) 12 (8)					●	●	●	●	●	●	●
50 / (14)	4	40	3 (2) 8 (6) 12 (8)					●	●	●	●	●	●	●
56 / (15)	4	45	3 (2) 8 (6) 12 (8)					●	●	●	●	●	●	●
63 / (16)	4	50	3 (2) 8 (6) 12 (8)					●	●	●	●	●	●	●
71 / (17)	4	56	3 (2) 8 (6) 12 (8)					●	●	●	●	●	●	●
76 / (18)	5.6	60	3 (2) 8 (6) 12 (8)						●	●	●	●	●	●
85 / (19)	5.6	66	3 (2) 8 (6) 12 (8)						●	●	●	●	●	●
90 / (20)	5.6	70	3 (2) 8 (6) 12 (8)						●	●	●	●	●	●
100 / (21)	5.6	78	3 (2) 8 (6) 12 (8)						●	●	●	●	●	●

Material:

HSS
Hardness 62 ± 2 HRC

Execution:

Diameter d₂ and end faces ground.
Special dimensions on request.

* For other radius options, see standardised special shapes.

Ordering Code (example): with anti-rotation element

2 6 5 5 . 1 0 F 8 . 1 3 5 0 . 0 6 5 0 . A 3

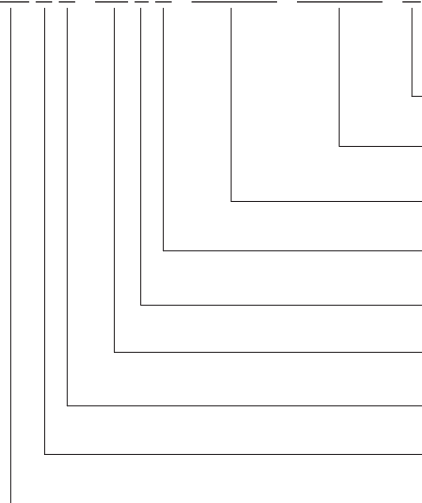

Anti-rotation element: Order No = (3)
Pin Ø 6 mm

Angle: Order Code character = (A)
0°

Shape: rectangle with radiused corners, Width W
W = 6,5 mm = (0650)

Shape: rectangle with radiused corners, Length P
P = 13,5 mm = (1350)

Shape cutting length: l Order No = (8)
12 mm

Length: l₁ Order Code character = (F)
28 mm

Diameter: d₂ Order No = (10)
32 mm

Type: without shoulder Order No = (5)
Automotive Standard

Execution: Order No = (5)
rectangle with radiused corners

Matrices:
Matrices = 26

MATRIX WITHOUT SHOULDER, AUTOMOTIVE STANDARD, ANTI-ROTATION ELEMENTS

Anti-rotation element 1 (1)

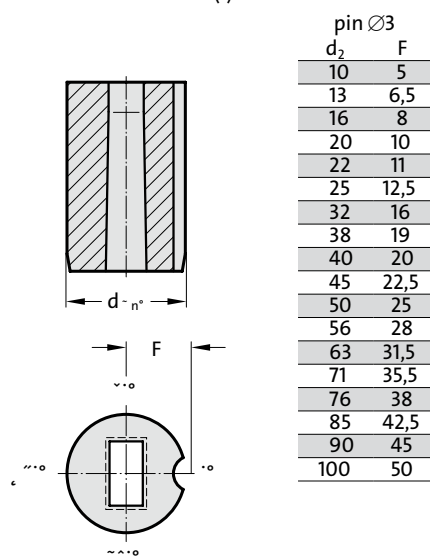

Anti-rotation element 2 (2)

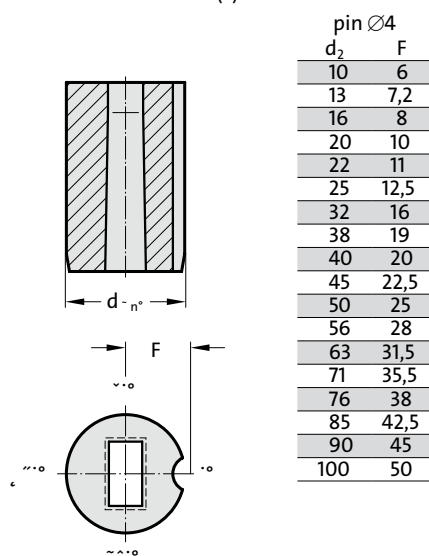

Anti-rotation element 3 (3)

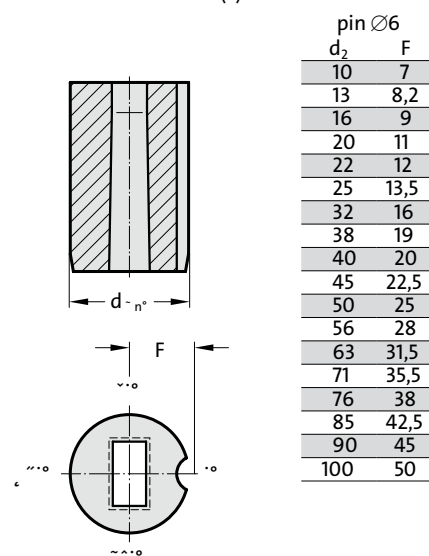

Anti-rotation element 4 (4)

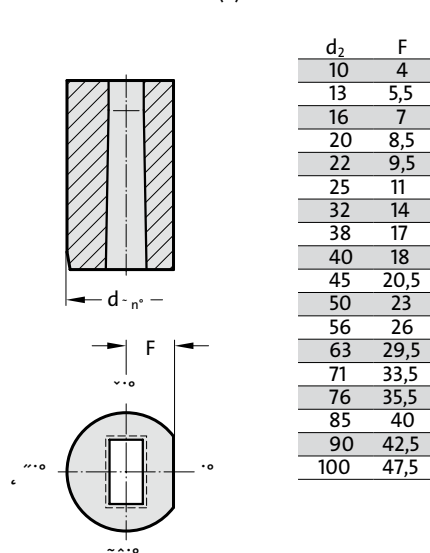

Anti-rotation element 5 (5)

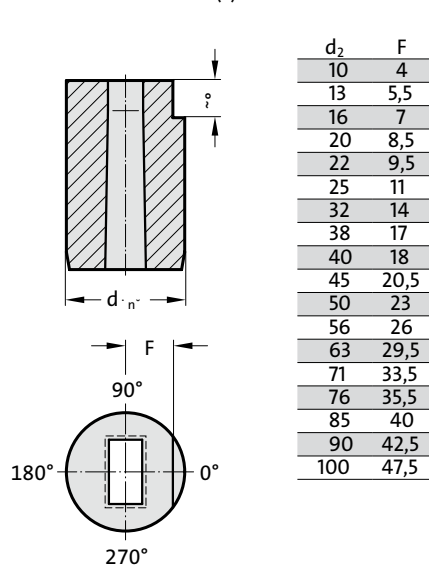

Anti-rotation element 6 (6)

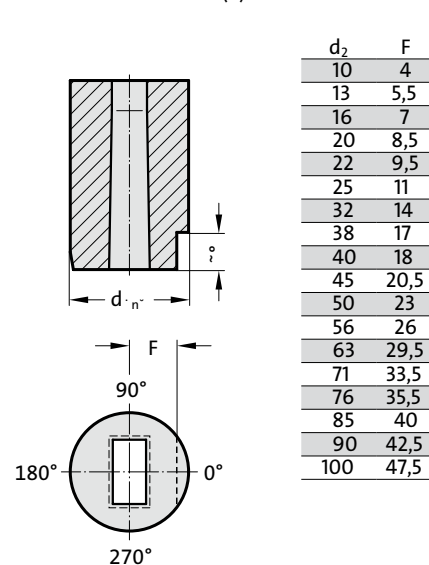

Guide bush for punch DIN 9845, Shape C



262.

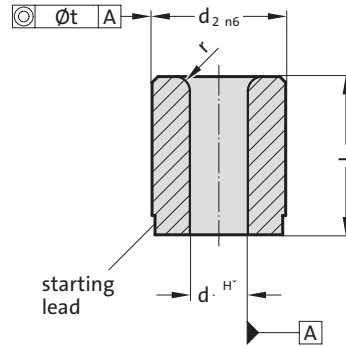

262. Guide bush for punch DIN 9845, Shape C

Gradation		d_1	d_2	t	l_1	r
0.5 - 1	0.1	5	0.01	9	1	
1.1 - 2	0.1	6	0.01	12	1	
2.1 - 3	0.1	7	0.01	12	1	
3.1 - 4	0.1	8	0.01	12	1	
4.1 - 5	0.1	10	0.01	16	1	
5.1 - 6	0.1	12	0.02	16	1.5	
6.1 - 8	0.1	15	0.02	20	1.5	
8.1 - 10	0.1	18	0.02	20	2	
10.1 - 12	0.1	22	0.02	28	2	
12.1 - 15	0.1	26	0.02	28	2	
15.1 - 18	0.5	30	0.02	36	2	

Material:

Case hardened steel
Hardness 740 ± 40 HV 10

Execution:

Diameters d_1 , d_2 and starting lead ground.

Ordering Code (example):

Guide bush for punch DIN 9845, Shape C	= 262.1.
Guide diameter d_1	0.5 mm = 0050.
Length l_1	9 mm = 009
Order No	= 262.1. 0050. 009

Guide bush for punch ISO 8978

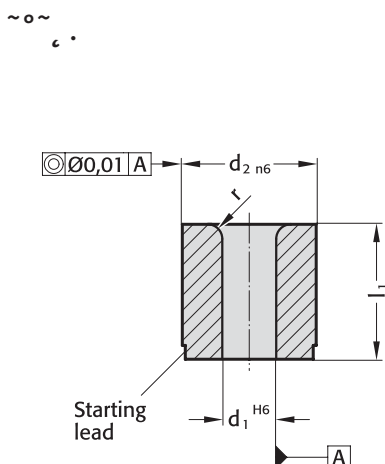

Material:

WS
Hardness 60 ± 2 HRC

Description of FIBRO materials for tool and die components see at the beginning of Chapter E.

Execution:

Diameters d_1 , d_2 and starting lead ground.

2621. Guide bush for punch ISO 8978

d_1	Gradation	d_2	l_1	r
1 - 2.4	0.1	5	8	1
1.6 - 3	0.1	6	12.5	1
2 - 3.5	0.1	8	12.5	1.5
3 - 5	0.1	10	16	2
4 - 7.2	0.1	13	16	2
6 - 8.8	0.1	16	20	2
7.5 - 11.3	0.1	20	20	2.5
11 - 16.6	0.1	25	25	2.5
15 - 20	0.5	32	25	4
18 - 27	0.5	40	32	4
26 - 36	0.5	50	40	4

Ordering Code (example):

Guide bush for punch ISO 8978	=2621.1.
Guide diameter d_1 1 mm	= 0100.
External diameter d_2 5 mm	= 0500
Order No	=2621.1. 0100. 0500

Matrix without collar, DIN 9845 Shape A



260.

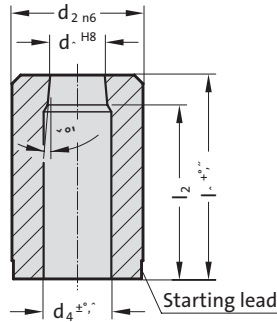

260. Matrix without collar, DIN 9845 Shape A

d ₁	Gradation	d ₂	l ₂	l ₂
0.5 - 1	0.1	5	l ₁ =20	l ₁ =28
1.1 - 2	0.1	6	17	25
2.1 - 3	0.1	7	17	25
3.1 - 4	0.1	8	17	25
4.1 - 5	0.1	10	16	24
5.1 - 6	0.1	12	16	24
6.1 - 8	0.1	15	16	24
8.1 - 10	0.1	18	16	24
10.1 - 12	0.1	22	15	23
12.1 - 15	0.1	26	15	23
15.1 - 18	0.1	30		23

Material:

HSS
Order No 260.3.
Hardness 62 ± 2 HRC

Description of FIBRO materials for tool and die components see at the beginning of Chapter E.

Execution:

Diameters d₁, d₂ and face surfaces ground.

d₄: For d₁ ≤ 2 mm, d₄ = d₁ + 0,3
For d₁ = 2,1 mm to 4,0 mm, d₄ = d₁ + 0,5
For d₁ = 4,1 mm to 8,0 mm, d₄ = d₁ + 0,7
For d₁ ≥ 8,1 mm, d₄ = d₁ + 1

Other diameters on request.

Ordering Code (example):

Matrix without collar, DIN 9845 Shape A	= 260.3.
Cutting diameter d ₁	0.5 mm = 0050.
Length l ₁	20 mm = 020
Order No	= 260.3. 0050. 020

Matrix with collar, DIN 9845 Shape B



261.

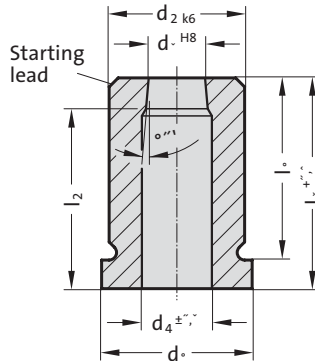

Material:

HSS
Order No 261.3.
Hardness 62 ± 2 HRC

Description of FIBRO materials for tool and die components see at the beginning of Chapter E.

Execution:

Diameters d_1 , d_2 and face surfaces ground.

d_4 : For $d_1 \leq 2$ mm, $d_4 = d_1 + 0,3$
For $d_1 = 2,1$ mm to 4,0 mm, $d_4 = d_1 + 0,5$
For $d_1 = 4,1$ mm to 8,0 mm, $d_4 = d_1 + 0,7$
For $d_1 \geq 8,1$ mm, $d_4 = d_1 + 1$

Other diameters on request.

261. Matrix with collar, DIN 9845 Shape B

d_1	Gradation		d_2	d_3	l_2	l_3	l_2	l_3
	d_1							
0.5 - 1	0.1		5	7	18	16		
1.1 - 2	0.1		6	8	17	16	25	24
2.1 - 3	0.1		7	9	17	16	25	24
3.1 - 4	0.1		8	10	17	16	25	24
4.1 - 5	0.1		10	12	16	16	24	24
5.1 - 6	0.1		12	14	16	16	24	24
6.1 - 8	0.1		15	17	16	16	24	24
8.1 - 10	0.1		18	20	16	16	24	24
10.1 - 12	0.1		22	24	15	16	23	24
12.1 - 15	0.1		26	28	15	16	23	24
15.1 - 18	0.1		30	32			23	24

Ordering Code (example):

Matrix with collar, DIN 9845 Shape B = 261.3.
Cutting diameter d_1 0.5 mm = 0050.
Length l_1 20 mm = 020
Order No = 261.3. 0050. 020

Matrix without collar, cylindrical



2602.

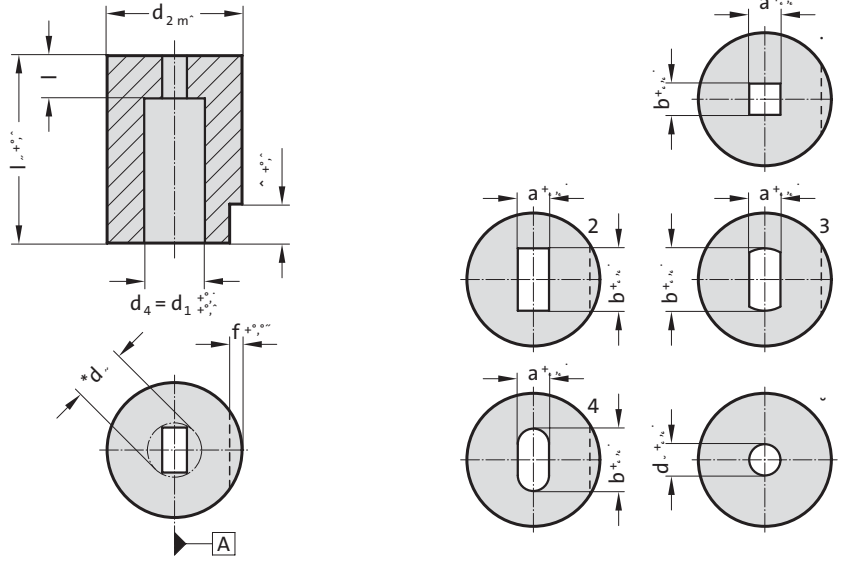

2602. Matrix without collar, cylindrical

d_1, d_5	d_2	l	f	l_1	l_1	l_1	l_1	l_1	l_1
1.8 - 3.2	8	3	1	●	●	●	●	●	●
2 - 5	10	3	1	●	●	●	●	●	●
3 - 7	13	3	1.5	●	●	●	●	●	●
5 - 8	16	5	1.5	●	●	●	●	●	●
7 - 11	20	5	1.5	●	●	●	●	●	●
11 - 16	25	5	2.5	●	●	●	●	●	●
16 - 19	32	7	2.5	●	●	●	●	●	●
19 - 28	40	7	2.5	●	●	●	●	●	●

Material:

HSS
Order No. 2602.3.
Hardness 64 ± 2 HRC

Execution:

Diameter d_2 and end faces ground.
Key flats parallel with reference axis "A" unless otherwise specified.
* d_1 = size over corners

With starting holes for wire-EDM as per 2601.

Ordering Code (example):

Matrix without collar, cylindrical	=2602.3.
Locating diameter d_2	8 mm = 008.
Length l_1	16 mm = 016.
Die shape Shape	Square = 1.
Width of die shape a	1.2 mm = 0120.
Die shape length b	1.2 mm = 0120
Order No	=2602.3. 008. 016. 1. 0120. 0120



Matrix with collar, cylindrical

2612.

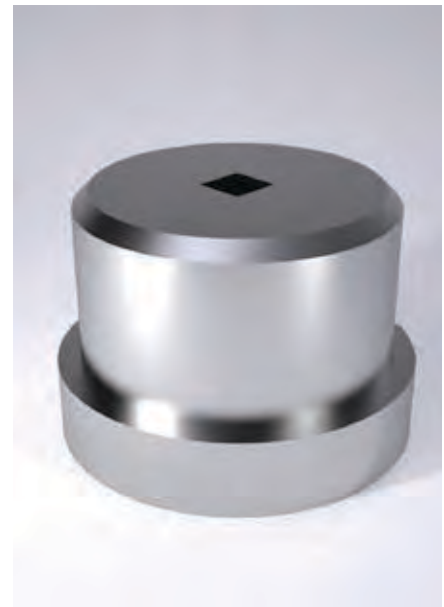
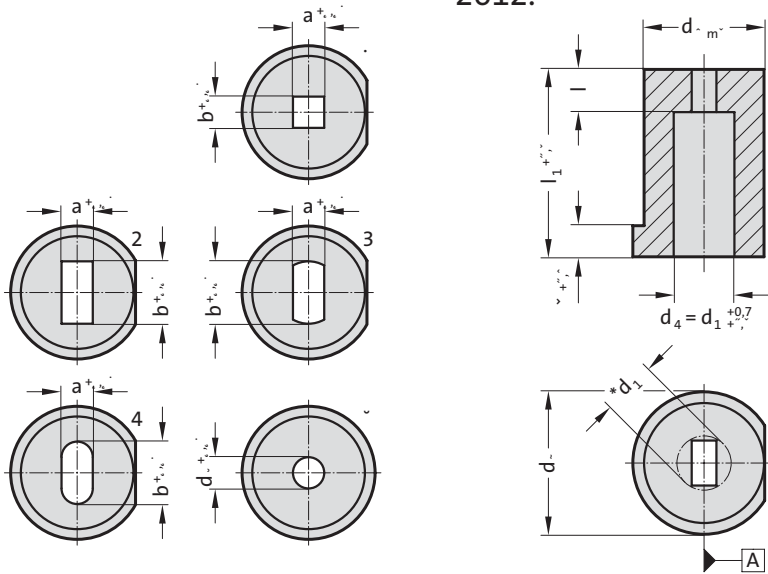

Material:

HSS
Order No. 2612.3.
Hardness 64 ± 2 HRC

Execution:

Diameter d_2 and end faces ground.
Key flats parallel with reference axis "A" unless otherwise specified.
* d_1 = size over corners

With starting holes for wire-EDM as per 2611.

2612. Matrix with collar, cylindrical

d_1, d_5	d_2	d_3	l	F	l_1	l_1	l_1	l_1	l_1	l_1
1.8 - 3.2	8	11	3	1	●	●	●	●	●	●
2 - 5	10	13	3	1	●	●	●	●	●	●
3 - 7	13	16	3	1.5	●	●	●	●	●	●
5 - 8	16	19	5	1.5	●	●	●	●	●	●
7 - 11	20	23	5	1.5	●	●	●	●	●	●
11 - 16	25	28	5	2.5	●	●	●	●	●	●
16 - 19	32	35	7	2.5	●	●	●	●	●	●
19 - 28	40	43	7	2.5	●	●	●	●	●	●

Ordering Code (example):

Matrix with collar, cylindrical	= 2612.3.
Locating diameter d_2	8 mm = 008.
Length l_1	16 mm = 016.
Die shape Shape	Square = 1.
Width of die shape a	1.2 mm = 0120.
Die shape length b	1.2 mm = 0120.
Order No	= 2612.3. 008. 016. 1. 0120. 0120

Matrix without collar, conical



2601.

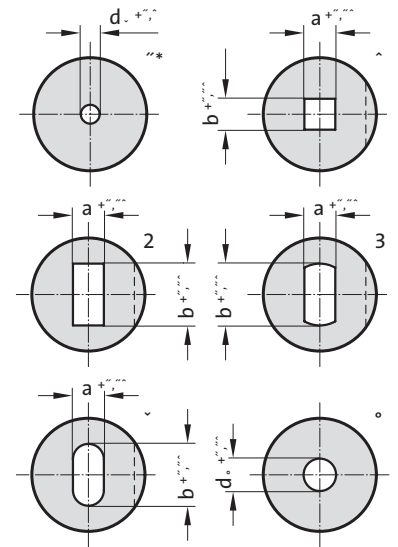
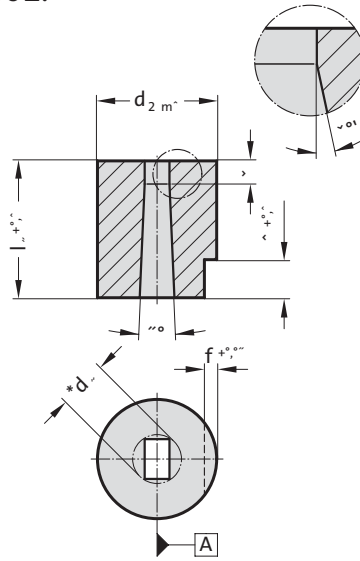

2601. Matrix without collar, conical

d_1, d_5	d_2	d_4	f	l_1	l_1	l_1	l_1	l_1	l_1
1.6 - 3.2	8	1	1	●	●	●	●	●	●
2 - 5	10	1	1	●	●	●	●	●	●
3 - 7	13	1.5	1.5	●	●	●	●	●	●
5 - 8	16	1.5	1.5	●	●	●	●	●	●
7 - 11	20	1.5	1.5	●	●	●	●	●	●
11 - 16	25	2.5	2.5	●	●	●	●	●	●
16 - 19	32	2.5	2.5	●	●	●	●	●	●
19 - 28	40	2.5	2.5	●	●	●	●	●	●

Material:

HSS
 Order No. 2601.3.
 Hardness 64 ± 2 HRC

Execution:

Diameter d_2 and end faces ground.
 Key flats parallel with reference axis "A" unless otherwise specified.
 * d_1 = size over corners
 *0 = Execution only with starting hole for wire-EDM

Ordering Code (example):

Matrix without collar, conical	= 2601.3.
Locating diameter d_2	8 mm = 008.
Length l_1	16 mm = 016.
Die shape Shape	Square = 1.
Width of die shape a	1.2 mm = 0120.
Die shape length b	1.2 mm = 0120
Order No	= 2601.3. 008. 016. 1. 0120. 0120



Matrix with collar, conical

2611.

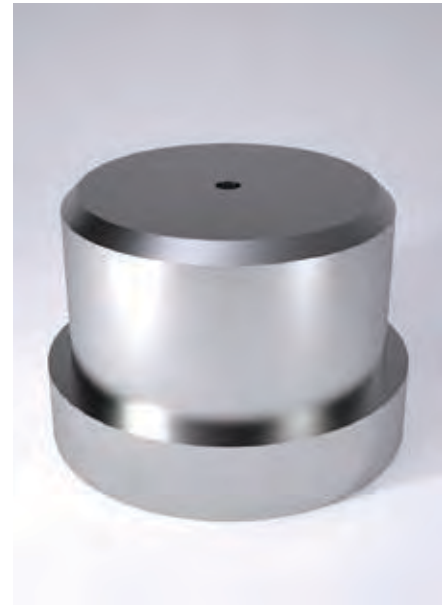
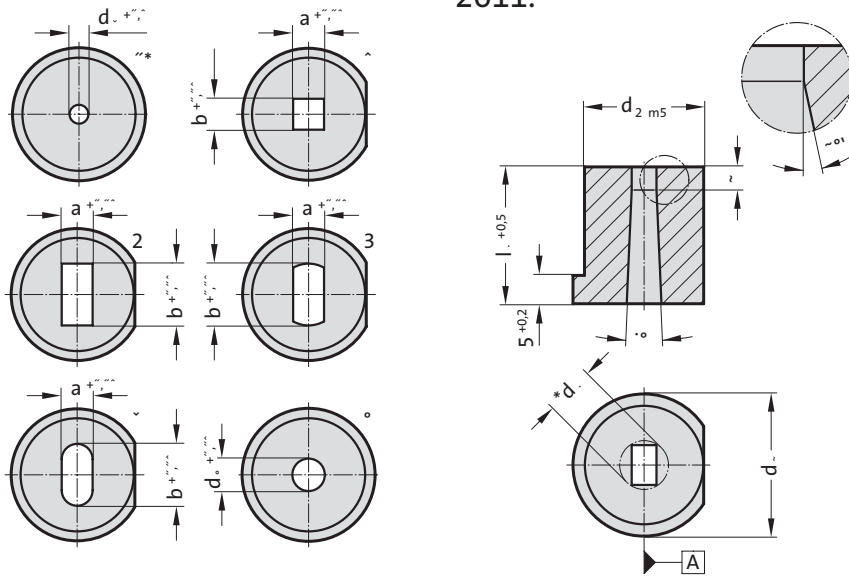

Material:

HSS

Order No. 2611.3.

Hardness 64 ± 2 HRC

Execution:

Diameter d_2 and end faces ground.

Key flats parallel with reference axis "A" unless otherwise specified.

* d_1 = size over corners

*0 = Execution only with starting hole for wire-EDM

2611. Matrix with collar, conical

d_1, d_5	d_2	d_3	d_4	l_1	l_1	l_1	l_1	l_1	l_1
1.6 - 3.2	8	11	1	●	●	●	●	●	●
2 - 5	10	13	1	●	●	●	●	●	●
3 - 7	13	16	1.5	●	●	●	●	●	●
5 - 8	16	19	1.5	●	●	●	●	●	●
7 - 11	20	23	1.5	●	●	●	●	●	●
11 - 16	25	28	2.5	●	●	●	●	●	●
16 - 19	32	35	2.5	●	●	●	●	●	●
19 - 28	40	43	2.5	●	●	●	●	●	●

Ordering Code (example):

Matrix with collar, conical	= 2611.3.
Locating diameter d_2	8 mm = 008.
Length l_1	16 mm = 016.
Die shape Shape	Square = 1.
Width of die shape a	1.2 mm = 0120.
Die shape length b	1.2 mm = 0120.
Order No	= 2611.3. 008. 016. 1. 0120. 0120

Standardised Special Shapes



Ordering examples

Special shapes Punches/Matrixes (standardised)

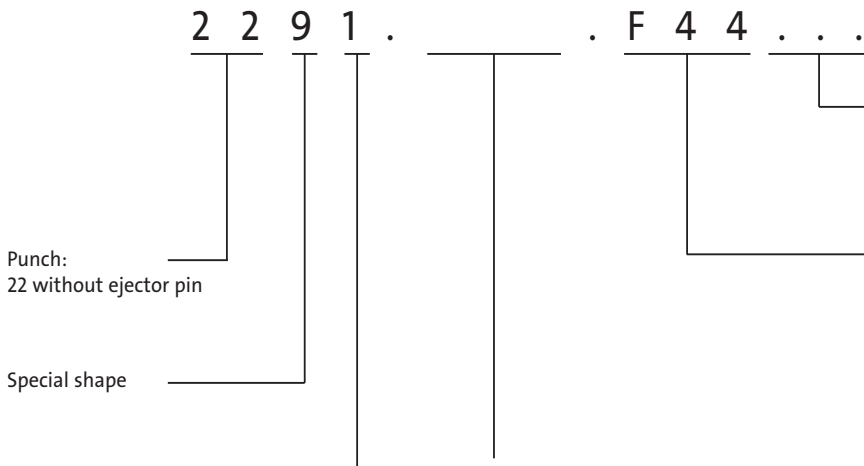

NB:
All the parameters must be given for special shapes!

Punch:
22 without ejector pin

Special shape

Special shape F 44

Type:	Order No
ISO 8020	= 1
ball-lock, light duty	= 2
ball-lock, heavy duty	= 3
ball-lock, larger cutting	= 4
edge, light duty	
ball-lock, larger cutting	= 5
edge, heavy duty	

You will find diameters and lengths on the pages of punches you have selected.

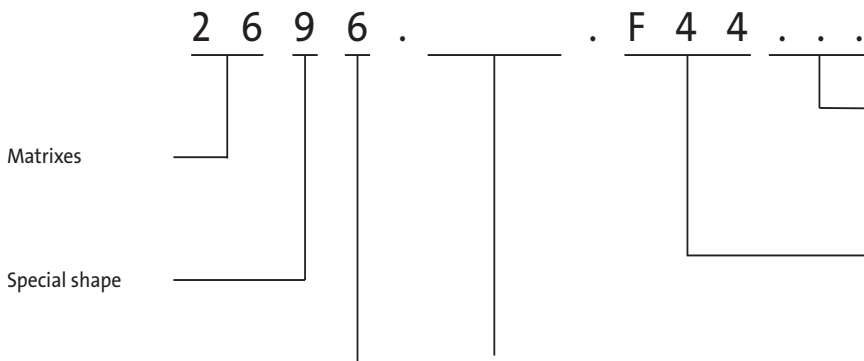
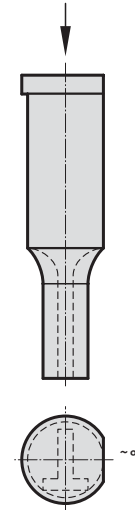

NB:
All the parameters must be given for special shapes!

Matrixes

Special shape

Special shape F 44

Type:	Order No
automotive	= 5
without shoulder	= 6
ISO 8977	
with shoulder ISO 8977	= 7

You will find diameters and lengths on the pages of cutting bushes you have selected.

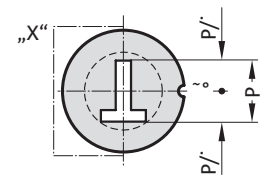
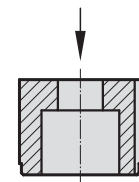

Cutting gap (a)

Roundings with the corresponding sharp corners reduce the cutting gap per side (a). If the cutting gap is 0.04 mm (a) or less, FIBRO will round the sharp edges if the cutting punch and the matrixes are ordered together. This reduces the installation time and the risk of an edge breaking during operation.

Note:

- (1) and (2) - roundings and sharp edges
- (1) rounding on the cutting punch of max. R0.2, corresponds to a sharp edge on the matrix
- (2) rounding on the cutting matrix of max. R0.2, corresponds to a sharp edge on the punch

View „X“

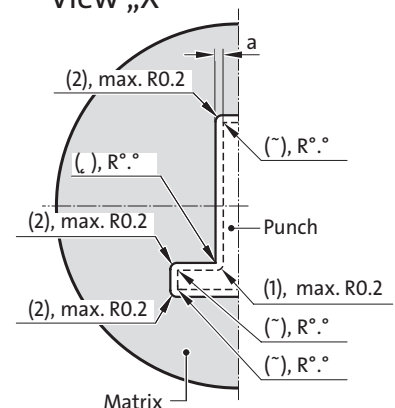

Standardised special shapes

90°

Round, flattened

F10

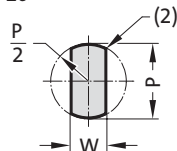

F[~]

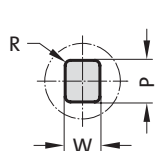

Key-hole shapes

F[°]

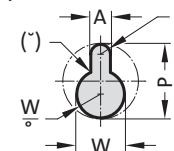

F[~]

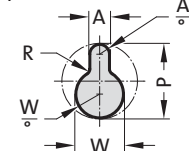

F54

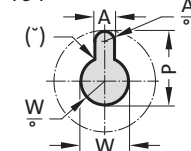

F[~]

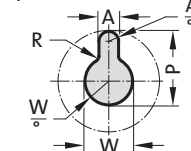

F33

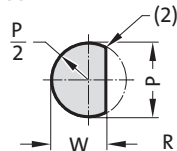

F_c[~]

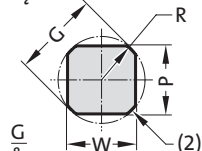

F14

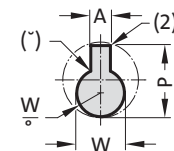

F56

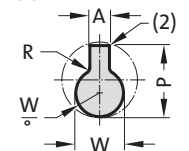

F[~]

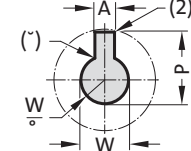

F[~]

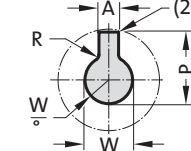

Various

F41

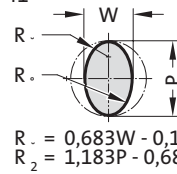

F[~]

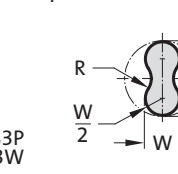

F64

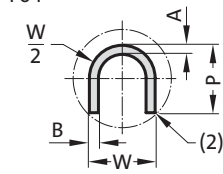

F65

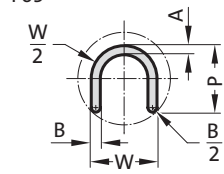

F_c[~]

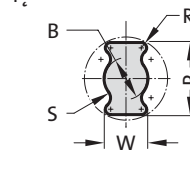

F_c[~]

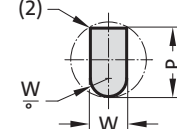

F_c[^]

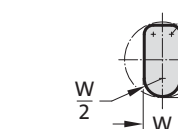

F16

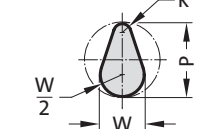

F34

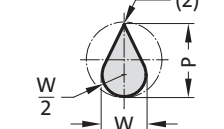

180° Triangles, trapezes

F_c[^]

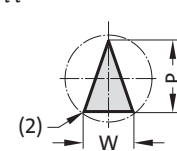

F_c[~]

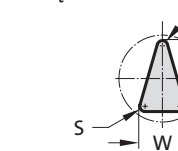

F24

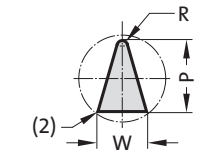

F_c[~]

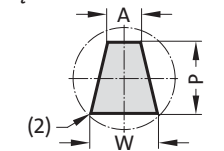

F26

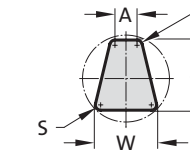

Key-hole

F30

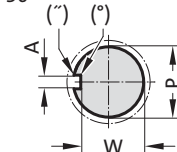

F[°]

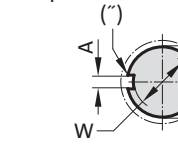

F_c[°]

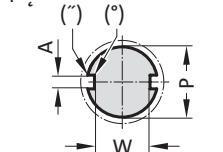

F61

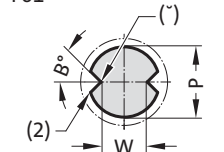

F62

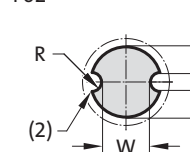

Polygons

F_c[°]

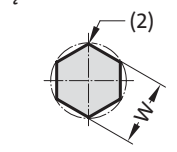

F[~]

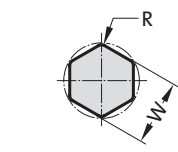

F[~]

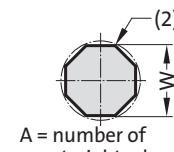

F86

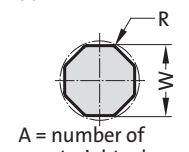

F36

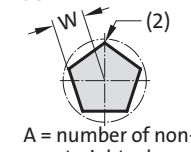

F[~]

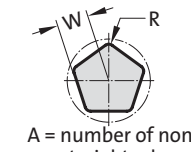

F[~]

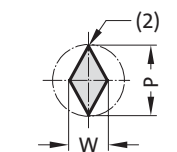

F[~]

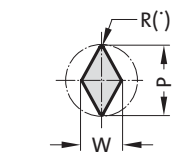

F[~]

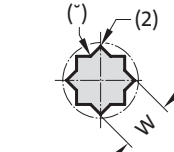

F[~]

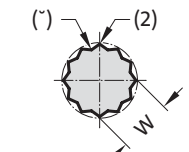

F[~]

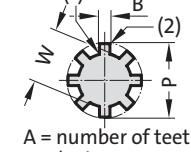

F90

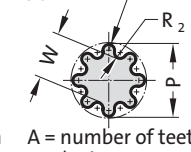

270°

Ordering examples

Special shapes Punches/Matrixes (standardised)

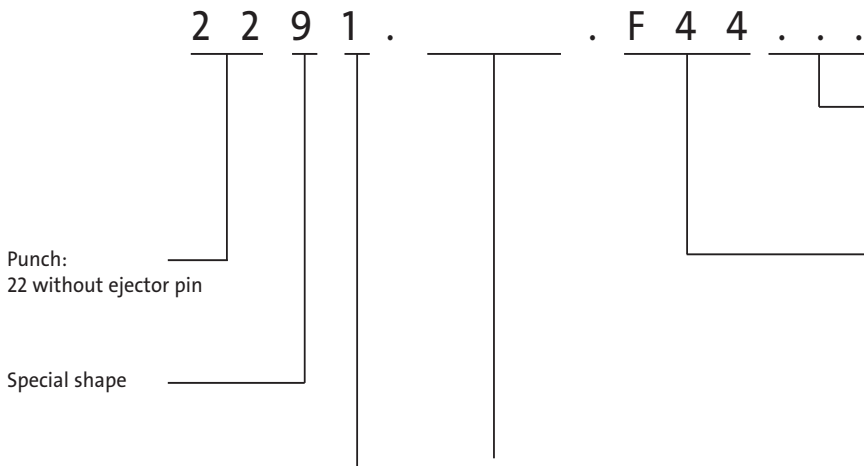

NB:
All the parameters must be given for special shapes!

Punch:
22 without ejector pin

Special shape

Special shape F 44

Type:	Order No
ISO 8020	= 1
ball-lock, light duty	= 2
ball-lock, heavy duty	= 3
ball-lock, larger cutting	= 4
edge, light duty	
ball-lock, larger cutting	= 5
edge, heavy duty	

You will find diameters and lengths on the pages of punches you have selected.

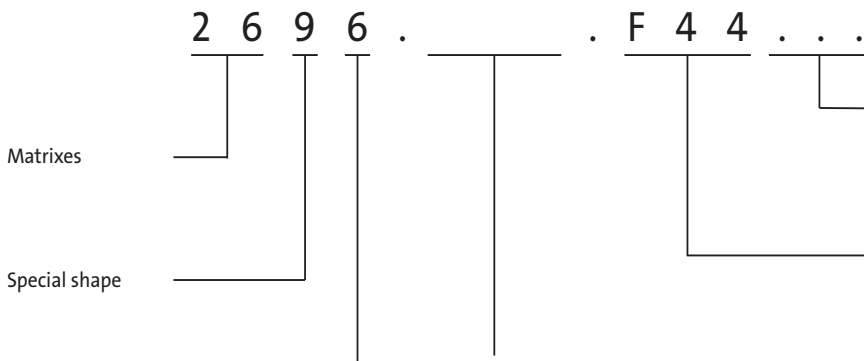
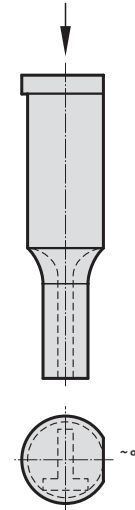

NB:
All the parameters must be given for special shapes!

Matrixes

Special shape

Special shape F 44

Type:	Order No
automotive	= 5
without shoulder	= 6
ISO 8977	
with shoulder ISO 8977	= 7

You will find diameters and lengths on the pages of cutting bushes you have selected.

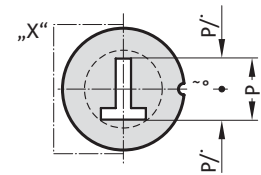
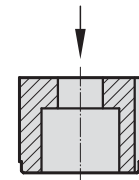

Cutting gap (a)

Roundings with the corresponding sharp corners reduce the cutting gap per side (a). If the cutting gap is 0.04 mm (a) or less, FIBRO will round the sharp edges if the cutting punch and the matrixes are ordered together. This reduces the installation time and the risk of an edge breaking during operation.

Note:

- (1) and (2) - roundings and sharp edges
- (1) rounding on the cutting punch of max. R0.2, corresponds to a sharp edge on the matrix
- (2) rounding on the cutting matrix of max. R0.2, corresponds to a sharp edge on the punch

View „X“

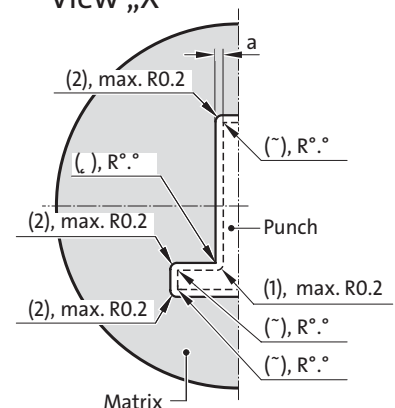

90°

Multi key-hole shapes

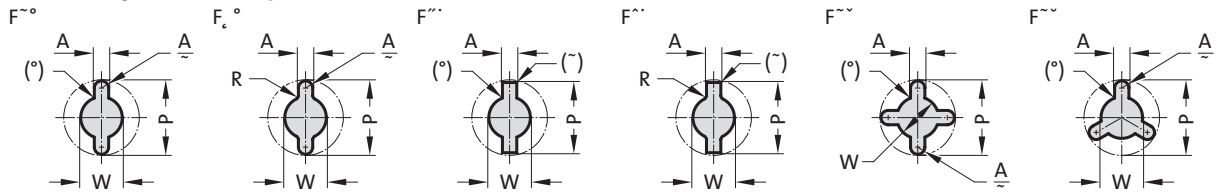

Double T-shapes

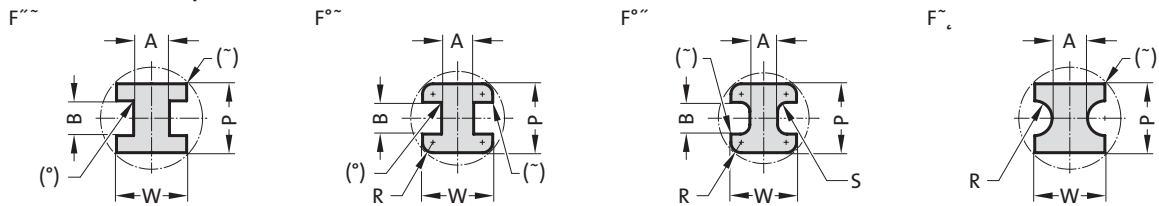

Simple T-shapes

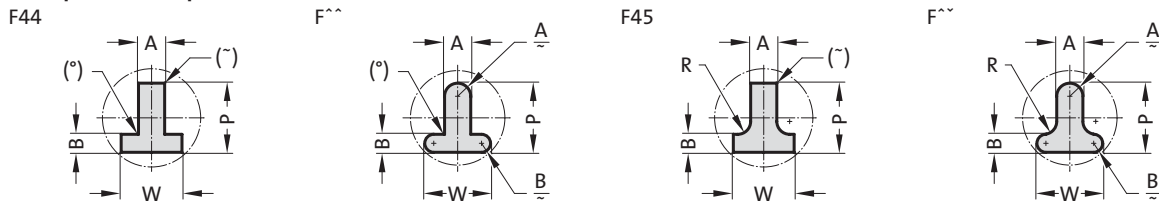

L-shapes

180°

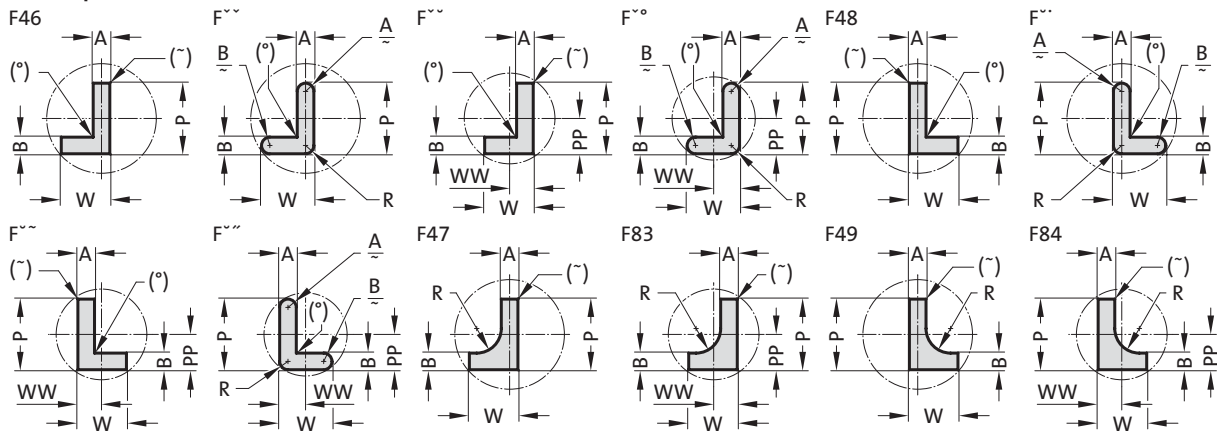

0°

U-shapes

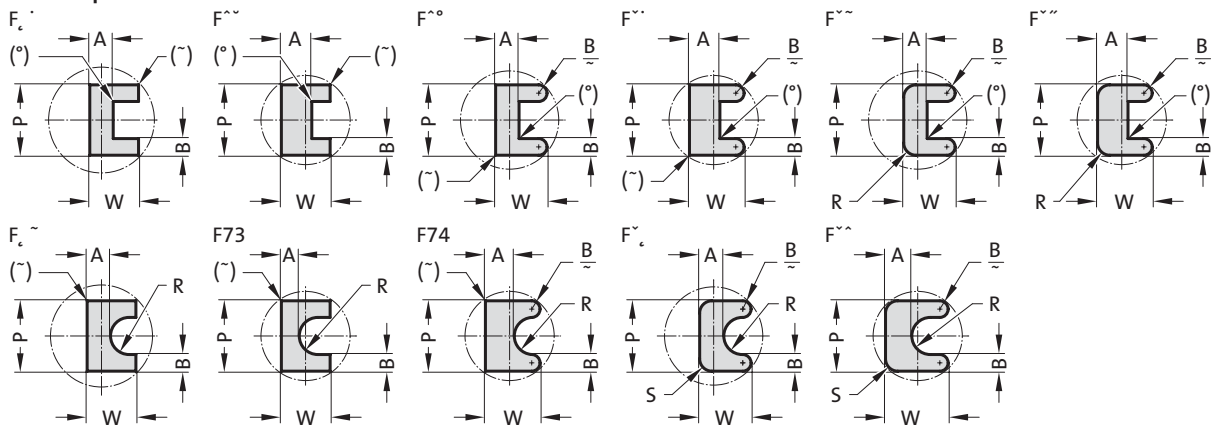

270°

Dynamic stripping element (DAE)



2618.

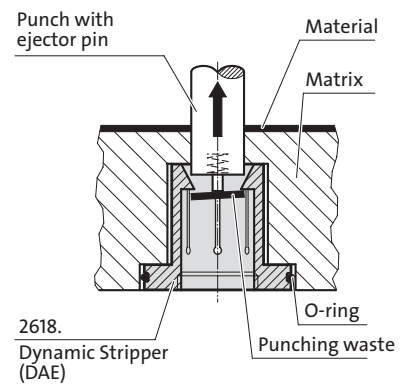
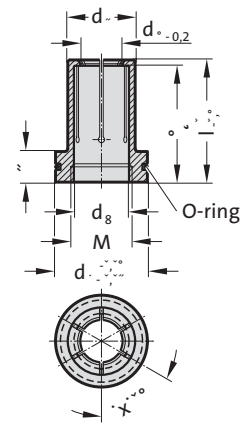

Description:

The dynamic stripper is used in blanking tools for punching operations using material up to 2 mm thick. The stripper is below the die. It is similar in shape to a segmented chuck. After the punching operation the punch enters the stripper with the punch waste still attached. The dynamic stripper opens up to receive the punch. On the return stroke the dynamic stripper strips the punch waste from the punch. The stripping element diameter d_1 is manufactured 0.2 mm smaller than the diameter p of the punch. To ensure reliable stripping the minimum entry depth into the dynamic stripper must be no less than 1 mm. The dynamic stripper can help to protect both the tool and the product from damage and also accelerate the production rate.

Material:

Steel, hardened

Mounting example

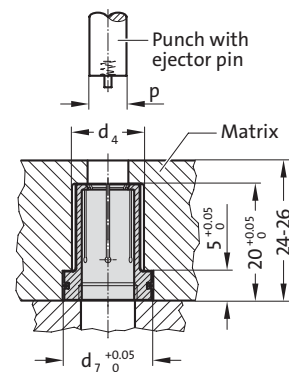

Mounting example

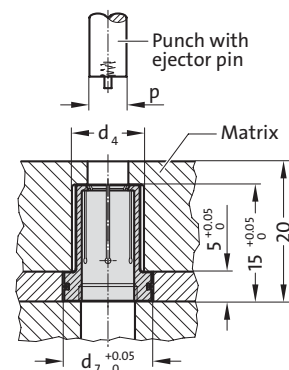

Dynamic stripping element (DAE)



2618. Dynamic stripping element (DAE)

Cutting punch p	DAE		Matrix				
	d ₁ Order-Ø	d ₅	d ₆	l	M	d ₄	d ₇
3.00-3.09	3	7	11	19.95	M6	8	11
3.10-3.19	3.1	7	11	19.95	M6	8	11
3.20-3.29	3.2	7	11	19.95	M6	8	11
3.30-3.39	3.3	7	11	19.95	M6	8	11
3.40-3.49	3.4	7	11	19.95	M6	8	11
3.50-3.59	3.5	7	11	19.95	M6	8	11
3.60-3.69	3.6	7	11	19.95	M6	8	11
3.70-3.79	3.7	7	11	19.95	M6	8	11
3.80-3.89	3.8	7	11	19.95	M6	8	11
3.90-3.99	3.9	7	11	19.95	M6	8	11
4.00-4.09	4	7	11	19.95	M6	8	11
4.10-4.19	4.1	8	12	19.95	M8	9	12
4.20-4.29	4.2	8	12	19.95	M8	9	12
4.30-4.39	4.3	8	12	19.95	M8	9	12
4.40-4.49	4.4	8	12	19.95	M8	9	12
4.50-4.59	4.5	8	12	19.95	M8	9	12
4.60-4.69	4.6	8	12	19.95	M8	9	12
4.70-4.79	4.7	8	12	19.95	M8	9	12
4.80-4.89	4.8	8	12	19.95	M8	9	12
4.90-4.99	4.9	8	12	19.95	M8	9	12
5.00-5.09	5	8	12	19.95	M8	9	12
5.10-5.19	5.1	9	13	19.95	M8	10	13
5.20-5.29	5.2	9	13	19.95	M8	10	13
5.30-5.39	5.3	9	13	19.95	M8	10	13
5.40-5.49	5.4	9	13	19.95	M8	10	13
5.50-5.59	5.5	9	13	19.95	M8	10	13
5.60-5.69	5.6	9	13	19.95	M8	10	13
5.70-5.79	5.7	9	13	19.95	M8	10	13
5.80-5.89	5.8	9	13	19.95	M8	10	13
5.90-5.99	5.9	9	13	19.95	M8	10	13
6.00-6.09	6	9	13	19.95	M8	10	13
6.10-6.19	6.1	10	14	19.95	M10	11	14
6.20-6.29	6.2	10	14	19.95	M10	11	14
6.30-6.39	6.3	10	14	19.95	M10	11	14
6.40-6.49	6.4	10	14	19.95	M10	11	14
6.50-6.59	6.5	10	14	19.95	M10	11	14
6.60-6.69	6.6	10	14	19.95	M10	11	14
6.70-6.79	6.7	10	14	19.95	M10	11	14
6.80-6.89	6.8	10	14	19.95	M10	11	14
6.90-6.99	6.9	10	14	19.95	M10	11	14
7.00-7.09	7	10	14	19.95	M10	11	14
7.10-7.19	7.1	11	15	19.95	M10	12	15
7.20-7.29	7.2	11	15	19.95	M10	12	15
7.30-7.39	7.3	11	15	19.95	M10	12	15
7.40-7.49	7.4	11	15	19.95	M10	12	15
7.50-7.59	7.5	11	15	19.95	M10	12	15
7.60-7.69	7.6	11	15	19.95	M10	12	15
7.70-7.79	7.7	11	15	19.95	M10	12	15
7.80-7.89	7.8	11	15	19.95	M10	12	15
7.90-7.99	7.9	11	15	19.95	M10	12	15
8.00-8.09	8	11	15	19.95	M10	12	15

Ordering Code (example):

Dynamic stripping element (DAE)	= 2618.
External diameter d ₅	7 mm = 07.
Order length BL	20 mm = 020.
Order diameter d ₁	3 mm = 0300
Order No	= 2618. 07. 020. 0300

Ordering Code (example) Matrixes for Dynamic Stripper (DAE)

Note:

See table
for standard dimensions

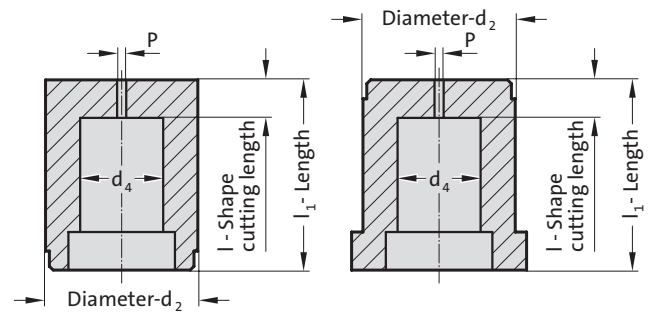
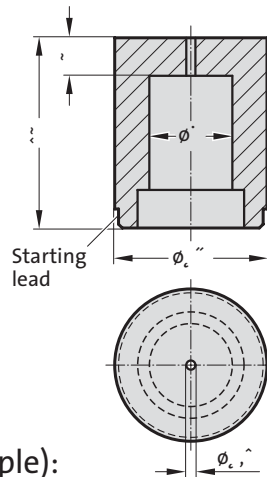

Ordering Code (example):

2618.06.6E4.09

- (09) $d_4 = 9 \text{ mm}$
- (4) Shape cutting length:
 $l = 5 \text{ mm}$
- (E) Length:
 $l_1 = 25 \text{ mm}$
- (6) Diameter:
 $d_2 = 16 \text{ mm}$
- (6) Type: without collar for
Dynamic Stripper DAE
- (0) Version:
Blank
(pilot hole bore)
- (2618) Matrix
for Dynamic Stripper
(DAE)

- $d_4 = 9 \text{ mm}$
- Shape cutting length l Order No
5 = 4
- Length l_1 Order Code character
25 = E
- Diameter d_2 Order No
13 = 5
16 = 6
20 = 7
- Type Order No
without collar for DAE = 6
with collar for DAE = 7
- Version Order No
blank = 0
(pilot hole bore)
- Matrixes
for Dynamic Stripper (DAE)

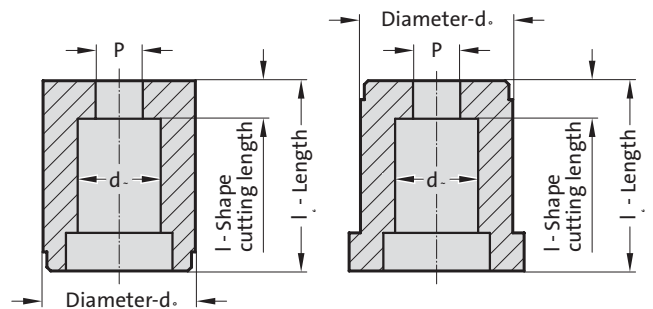
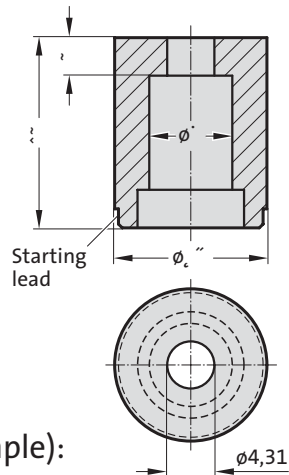

Ordering Code (example):

2618.16.6E4.0431

- (0431) Shape:
Round, $P = 4,31 \text{ mm}$
- (4) Shape cutting length:
 $l = 5 \text{ mm}$
- (E) Shape cutting length:
 $l_1 = 25 \text{ mm}$
- (6) Diameter:
 $d_2 = 16 \text{ mm}$
- (6) Type: without collar for
Dynamic Stripper DAE
- (1) Version:
Round
- (2618) Matrix for
Dynamic Stripper
(DAE)

- Shape: Round, $P = 4,31 \text{ mm}$
- Shape cutting length l Order No
5 = 4
- Length l_1 Order Code character
25 = E
- Diameter d_2 Order No
13 = 5
16 = 6
20 = 7
- Type Order No
without collar for DAE = 6
with collar for DAE = 7
- Version Order No
Round = 1
- Matrixes
for Dynamic Stripper (DAE)

Matrix without collar for dynamic stripper (DAE), blank



2618.06.

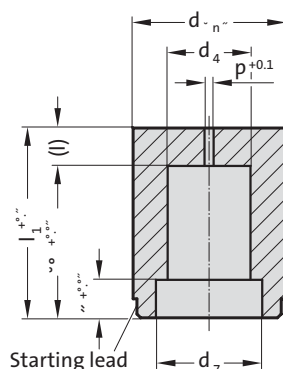

2618.06. Matrix without collar for dynamic stripper (DAE), blank

d_2	d_4	d_7	p	l	l_1
13	8	11	1.2	5	25
16	9	12	1.2	5	25
16	10	13	1.5	5	25
20	11	14	1.5	5	25
20	12	15	1.5	5	25

Ordering-code (example):

2 6 1 8 . 0 6 . 6 E 4 . 0 9

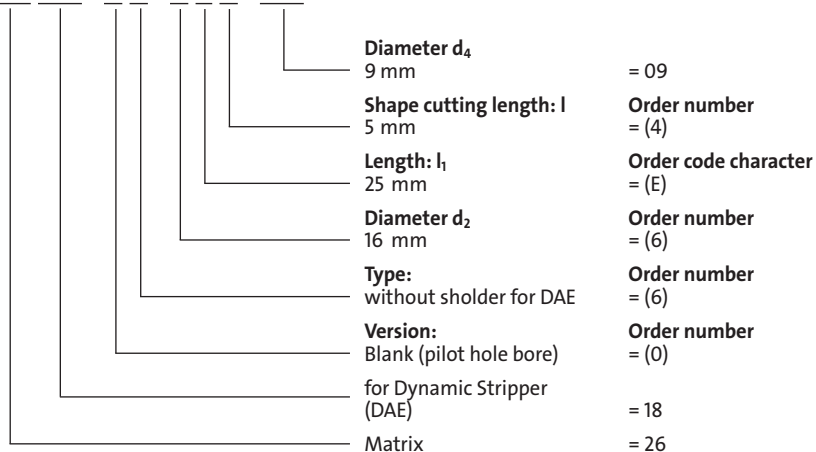

Material:

HSS
Hardness 62 ± 2 HRC

Execution:

Diameter d_2 , starting lead and face surfaces ground.
Diameter P is a bored pilot hole for wire EDM.

Note:

Order dynamic stripping element (DAE) separately.

Matrix with collar for dynamic stripper (DAE), blank



2618.07.

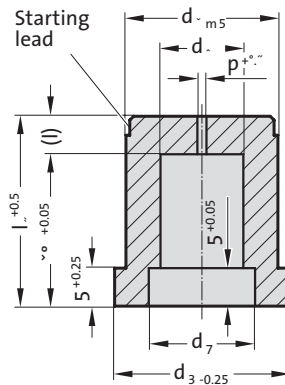

2618.07. Matrix with collar for dynamic stripper (DAE), blank

d_2	d_3	d_4	d_7	p	l	l_1
13	16	8	11	1.2	5	25
16	19	9	12	1.2	5	25
16	19	10	13	1.5	5	25
20	23	11	14	1.5	5	25
20	23	12	15	1.5	5	25

Material:

HSS
Hardness 62 ± 2 HRC

Execution:

Diameter d_2 , starting lead and face surfaces ground.
Diameter P is a bored pilot hole for wire EDM.

Note:

Order dynamic stripping element (DAE) separately.

Ordering-code (example):

2 6 1 8 . 0 7 . 6 E 4 . 0 9

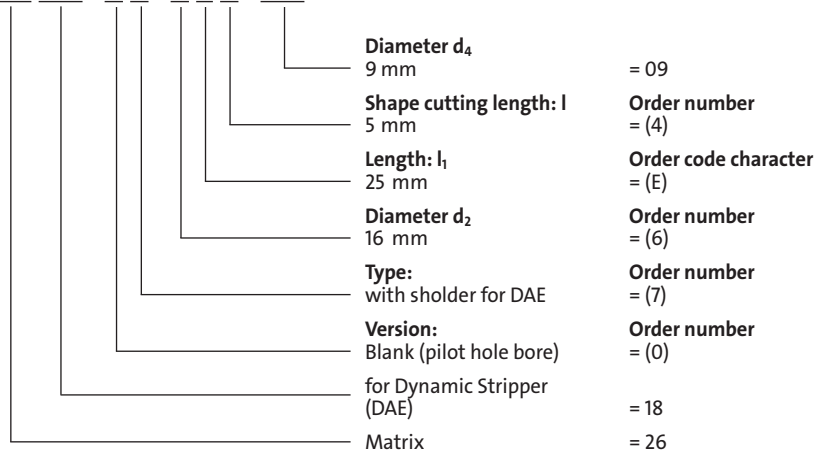

MATRIX WITHOUT COLLAR FOR DYNAMIC STRIPPER (DAE), ROUND

2618.16.

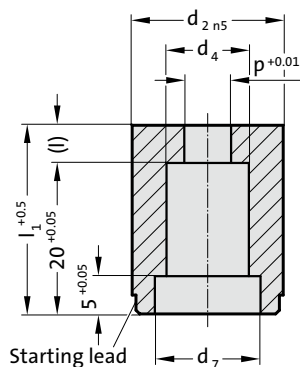

2618.16. Matrix without collar for dynamic stripper (DAE), round

d ₂	d ₄	d ₇	l	l ₁	Matrix	DAE	d ₁
					Diameter steps 0.01		
13	8	11	5	25	3 - 4,29	7	3-4
16	9	12	5	25	4,3 - 5,29	8	4.1-5
16	10	13	5	25	5,3 - 6,29	9	5.1-6
20	11	14	5	25	6,3 - 7,29	10	6.1-7
20	12	15	5	25	7,3 - 8,29	11	7.1-8



Ordering Code (example):

2618.16.6E4.0431

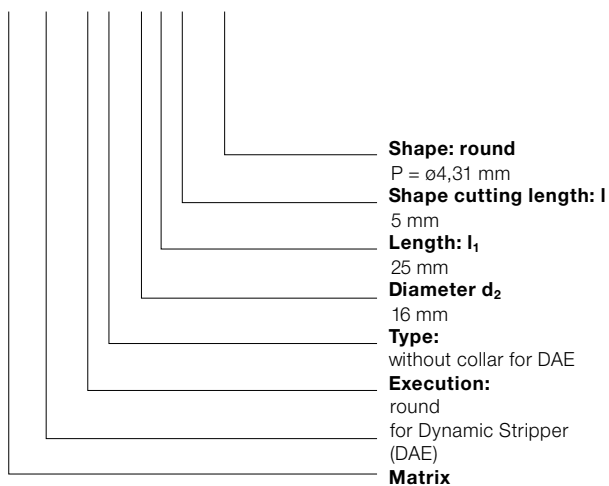

= 0431
Order No
 = (4)
Order Code character
 = (E)
Order No
 = (6)
Order No
 = (6)
Order No
 = (1)
 = 18
 = 26

Material:

HSS
 Hardness 62 ± 2 HRC

Execution:

Diameter d₂, starting lead and end faces ground.

Note:

Order dynamic stripping element (DAE) separately.

MATRIX WITH COLLAR FOR DYNAMIC STRIPPER (DAE), ROUND



2618.17.

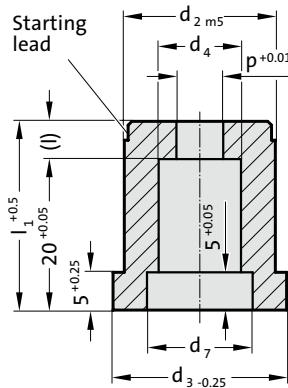

2618.17. Matrix with collar for dynamic stripper (DAE), round

d_2	d_3	d_4	d_7	l	l_1	Matrix	DAE	d_1
						Diameter steps 0.01		
13	16	8	11	5	25	P	7	3-4
16	19	9	12	5	25	3 - 4,29	8	4.1-5
16	19	10	13	5	25	4,3 - 5,29	9	5.1-6
20	23	11	14	5	25	5,3 - 6,29	10	6.1-7
20	23	12	15	5	25	6,3 - 7,29	11	7.1-8
						7,3 - 8,29		



Material:

HSS
Hardness 62 ± 2 HRC

Execution:

Diameter d_2 , starting lead and end faces ground.

Note:

Order dynamic stripping element (DAE) separately.

Ordering Code (example):

2618.17.6E4.0431

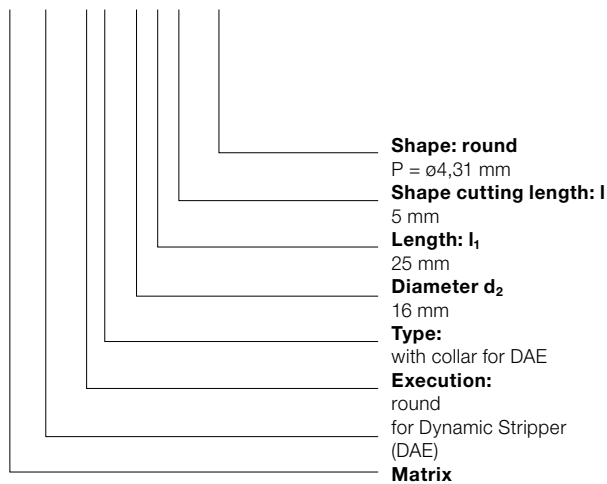

= 0431
Order No
= (4)
Order Code character
= (E)
Order No
= (6)
Order No
= (7)
Order No
= (1)
= 18
= 26



Retainers for ball-lock punches



Triangle retainer for ball-lock punches, light duty

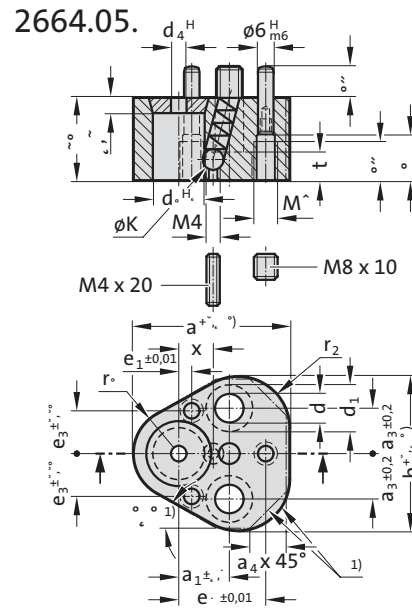

Execution:

Version for metal thicknesses up to 3 mm. The punch locating hole d_2 is manufactured to a tolerance of ± 0.01 mm relative to the 6 stud holes H7. This ensures the interchangeability of the locating plate with other polygon versions.

Note:

Special punch retainers available to order.

1) Contours may vary. Maximum dimensions are specified in the table.

2664.05. Triangle retainer for ball-lock punches, light duty

Order No	d	d ₁	d ₂	d ₄	a	a ₁	a ₃	a ₄	b	e ₁	e ₂	e ₃	ØK	t	r ₁	r ₂	x
2664.05.10	9	15	10	6	44.5	19	11.1	10	43.7	7.5	26.925	9	8	9	9.5	12	8.2
2664.05.13	9	15	13	6	50.8	19	14.3	12	50	6.5	29.97	12	8	9	12.7	15.2	9.5
2664.05.16	9	15	16	6	54	19	15.9	13	53.2	6	31.75	13.5	8	9	14.3	16.8	11.2
2664.05.20	11	18	20	6	60.3	19	17.5	14	59.5	5	33.53	16.5	8	11	17.5	20	13.2
2664.05.25	13.5	20	25	6	69.9	23.8	19.8	16	69.1	7	40.64	22	8	13.5	22.2	24.7	15.7
2664.05.32	13.5	20	32	6	69.9	23.8	19.8	16	69.1	7	40.64	22	8	13.5	22.2	24.7	19.25
2664.05.38	13.5	20	38	6	77.4	27	24	18	76.6	10	43.993	26	8	13.5	26	28.5	22.25



Triangle retainer for ball-lock punches, heavy duty

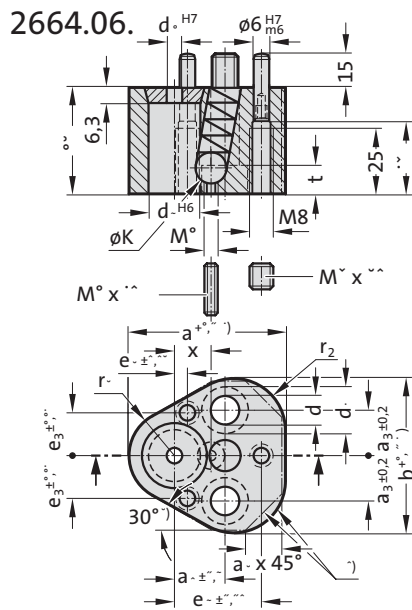

Execution:

Version for metal thicknesses > 3 mm/max. 6 mm. The punch locating hole d_2 is manufactured to a tolerance of ± 0.01 mm relative to the 6 stud holes H7. This ensures the interchangeability of the locating plate with other polygon versions.

Note:

Special punch retainers available to order.

1) Contours may vary. Maximum dimensions are specified in the table.

2664.06. Triangle retainer for ball-lock punches, heavy duty

Order No	d	d ₁	d ₂	d ₄	a	a ₁	a ₃	a ₄	b	e ₁	e ₂	e ₃	ØK	t	r ₁	r ₂	x
2664.06.10	9	15	10	6	44.5	19	11.1	10	43.7	7.5	26.925	9	10	9	9.5	12	9.8
2664.06.13	9	15	13	6	50.8	19	14.3	12	50	6.5	29.97	12	12	9	12.7	15.2	11.3
2664.06.16	9	15	16	6	54	19	15.9	13	53.2	6	31.75	13.5	12	9	14.3	16.8	12.8
2664.06.20	11	18	20	6	60.3	19	17.5	14	59.5	5	33.53	16.5	12	11	17.5	20	14.8
2664.06.25	13.5	20	25	6	69.9	23.8	19.8	16	69.1	7	40.64	22	12	13.5	22.2	24.7	17.3
2664.06.32	13.5	20	32	6	69.9	23.8	19.8	16	69.1	7	40.64	22	12	13.5	22.2	24.7	20.8
2664.06.40	13.5	20	40	6	77.4	27	24	18	76.6	10	43.993	26	12	13.5	26	28.5	24.8

Triangle retainer for ball-lock punches, light duty

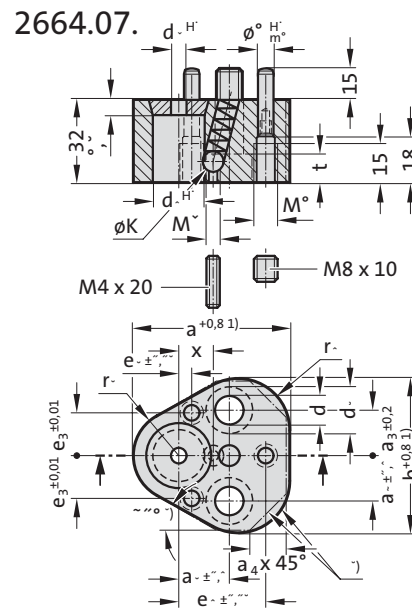

Execution:

Version for metal thicknesses up to 3 mm. The punch locating hole d_2 is manufactured to a tolerance of ± 0.01 mm relative to the 6 stud holes H7. This ensures the interchangeability of the locating plate with other polygon versions.

Note:

Special punch retainers available to order.

1) Contours may vary. Maximum dimensions are specified in the table.

2664.07. Triangle retainer for ball-lock punches, light duty

Order No	d	d ₁	d ₂	d ₄	a	a ₁	a ₃	a ₄	b	e ₁	e ₂	e ₃	ØK	t	r ₁	r ₂	x
2664.07.06	6.6	11	6	3	35	19	11.1	6	37.5	9	23	8	6	7	8	8	5.7



Triangle retainer for ball-lock punches, heavy duty

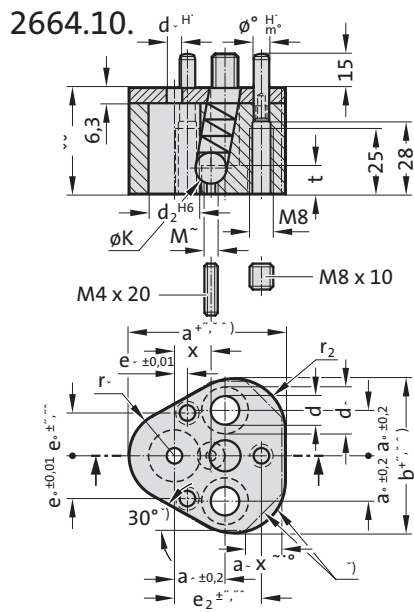

Execution:

Version for metal thicknesses > 3 mm/max. 6 mm. The punch locating hole d_2 is manufactured to a tolerance of ± 0.01 mm relative to the 6 stud holes H7. This ensures the interchangeability of the locating plate with other polygon versions.

Note:

Special punch retainers available to order.
Pressure plate welded.

1) Contours may vary. Maximum dimensions are specified in the table.

2664.10. Triangle retainer for ball-lock punches, heavy duty

Order No	d	d ₁	d ₂	d ₄	a	a ₁	a ₃	a ₄	b	e ₁	e ₂	e ₃	ØK	t	r ₁	r ₂	x
2664.10.10	9	15	10	6	44.5	19	11.1	10	43.7	7.5	26.925	9	10	9	9.5	12	9.8
2664.10.13	9	15	13	6	50.8	19	14.3	12	50	6.5	29.97	12	12	9	12.7	15.2	11.3
2664.10.16	9	15	16	6	54	19	15.9	13	53.2	6	31.75	13.5	12	9	14.3	16.8	12.8
2664.10.20	11	18	20	6	60.3	19	17.5	14	59.5	5	33.53	16.5	12	11	17.5	20	14.8
2664.10.25	13.5	20	25	6	69.9	23.8	19.8	16	69.1	7	40.64	22	12	13.5	22.2	24.7	17.3
2664.10.32	13.5	20	32	6	69.9	23.8	19.8	16	69.1	7	40.64	22	12	13.5	22.2	24.7	20.8
2664.10.40	13.5	20	40	6	77.4	27	24	18	76.6	10	43.993	26	12	13.5	26	28.5	24.8



Accessories for Retainers, triangular, for Ball-Lock Punches

	2192.10.	236.1.	2666.04.	2192.72.	2666.06.	2666.01. .1	2192.72.	
Retainer	Ø d ₂	Socket head cap screw	Dowel pin	Ball	Ball release pin	Spring	Pressure disk for centring pin	Pin screw
2664.05.	10	2192.10.08.035	236.1.0600.020	2666.04.008	2192.72.04.020	2666.06.008	2666.01.10.1	2192.72.08.008
	13	2192.10.08.035	236.1.0600.020	2666.04.008	2192.72.04.020	2666.06.008	2666.01.13.1	2192.72.08.008
	16	2192.10.08.035	236.1.0600.020	2666.04.008	2192.72.04.020	2666.06.008	2666.01.16.1	2192.72.08.008
	20	2192.10.10.035	236.1.0600.020	2666.04.008	2192.72.04.020	2666.06.008	2666.01.20.1	2192.72.08.008
	25	2192.10.12.035	236.1.0600.020	2666.04.008	2192.72.04.020	2666.06.008	2666.01.25.1	2192.72.08.008
	32	2192.10.12.035	236.1.0600.020	2666.04.008	2192.72.04.020	2666.06.008	2666.01.32.1	2192.72.08.008
	38	2192.10.12.035	236.1.0600.020	2666.04.008	2192.72.04.020	2666.06.008	2666.01.38.1	2192.72.08.008
2664.06./10.	10	2192.10.08.040	236.1.0600.020	2666.04.010	2192.72.04.020	2666.06.010	2666.01.10.1	2192.72.08.008
	13	2192.10.08.040	236.1.0600.020	2666.04.012	2192.72.04.020	2666.06.012	2666.01.13.1	2192.72.08.008
	16	2192.10.08.040	236.1.0600.020	2666.04.012	2192.72.04.020	2666.06.012	2666.01.16.1	2192.72.08.008
	20	2192.10.10.050	236.1.0600.020	2666.04.012	2192.72.04.020	2666.06.012	2666.01.20.1	2192.72.08.008
	25	2192.10.12.050	236.1.0600.020	2666.04.012	2192.72.04.020	2666.06.012	2666.01.25.1	2192.72.08.008
	32	2192.10.12.050	236.1.0600.020	2666.04.012	2192.72.04.020	2666.06.012	2666.01.32.1	2192.72.08.008
	40	2192.10.12.050	236.1.0600.020	2666.04.012	2192.72.04.020	2666.06.012	2666.01.40.1	2192.72.08.008
2664.07.	6	2192.10.06.035	236.1.0600.020	2666.04.006	2192.72.04.020	2666.06.006	2666.01.06.1	2192.72.08.008

Ball release tool

Hook shape	straight	straight with threaded tip
2666.05.01	2666.05.02	2666.05.03

ACCU-LOCK Fixture device for ball-lock punches, light duty



2668.2.

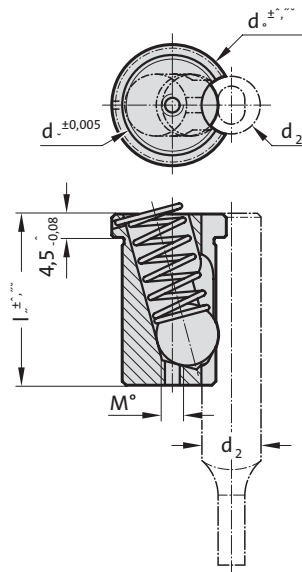

Note:

Use ball release tool 2666.05.02, straight.

Mounting example

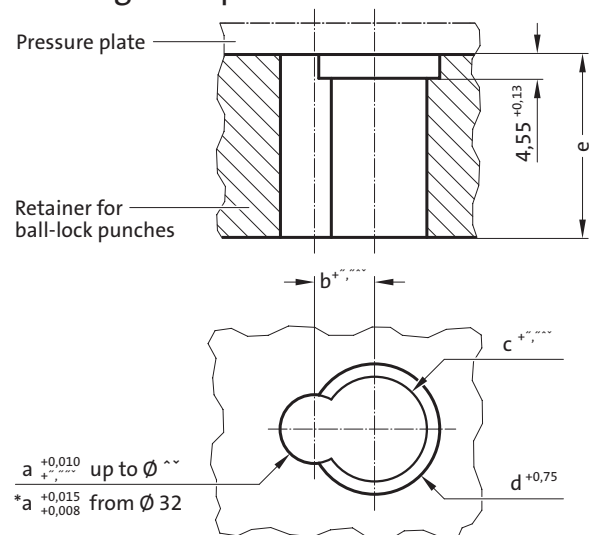

2668.2. ACCU-LOCK Fixture device for ball-lock punches, light duty

Order No	d ₂	d ₃	d ₄	l ₁	a	b	c	d	e
2668.2.06	6	12	14.6	25.7	6	6.5	12.013	15	25.7
2668.2.10	10	14	16.6	25.7	10	9	14.013	17	25.7
2668.2.13	13	14	16.6	25.7	13	10.5	14.013	17	25.7
2668.2.16	16	14	16.6	25.7	16	12	14.013	17	25.7
2668.2.20	20	16	18.6	25.7	20	14	16.013	19	25.7
2668.2.25	25	16	18.6	25.7	25	16.5	16.013	19	25.7
2668.2.32	32	16	18.6	25.7	32	20	16.013	19	25.7
2668.2.38	38	16	18.6	25.7	38	23	16.013	19	25.7

ACCU-LOCK Fixture device for ball-lock punches, heavy duty



2668.3.

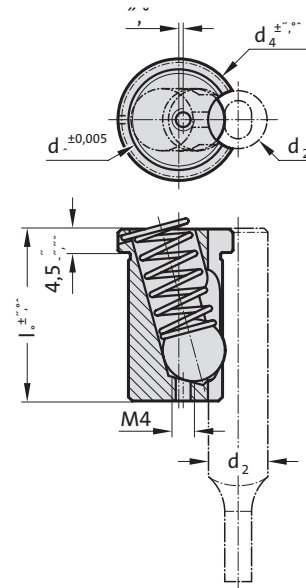

Mounting example

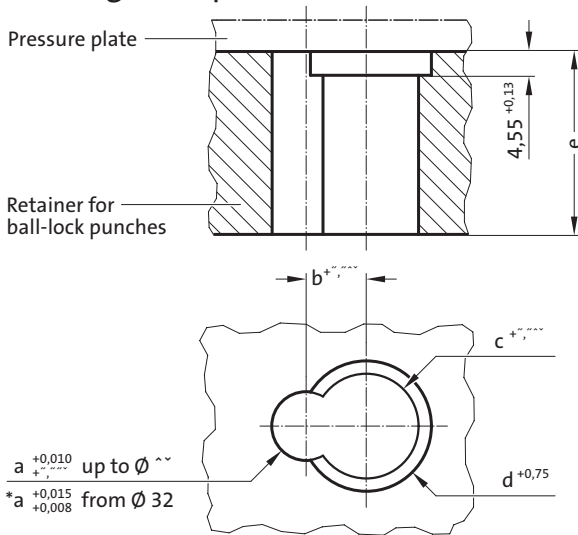

Note:

Use ball release tool 2666.05.02, straight.

2668.3. ACCU-LOCK Fixture device for ball-lock punches, heavy duty

Order No	d ₂	d ₃	d ₄	l ₁	a	b	c	d	e
2668.3.10	10	16	19.6	34.7	10	10	16.013	20	34.7
2668.3.13	13	20	24.6	34.7	13	11.5	20.013	25	34.7
2668.3.16	16	20	24.6	34.7	16	13	20.013	25	34.7
2668.3.20	20	20	24.6	34.7	20	15	20.013	25	34.7
2668.3.25	25	20	24.6	34.7	25	17.5	20.013	25	34.7
2668.3.32	32	20	24.6	34.7	32	21	20.013	25	34.7
2668.3.40	40	20	24.6	34.7	40	25	20.013	25	34.7



Retainer BOLT LOCK

Retainer BOLT LOCK



• • • • •

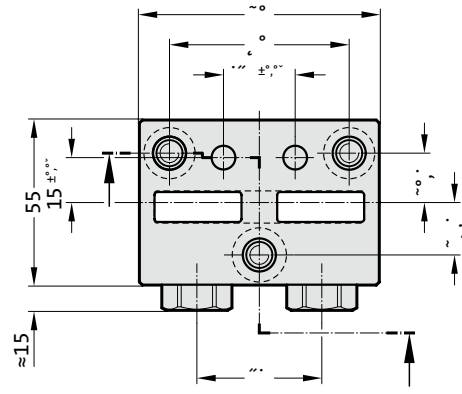
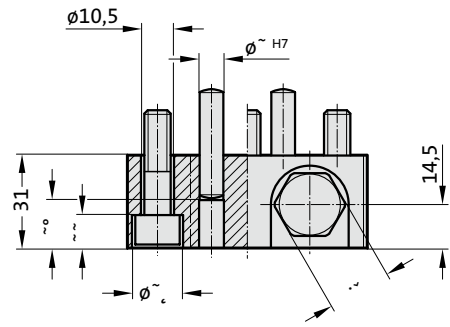

Material:

HWS (1.2379)
Hardness 60 +2 HRC

Note:

Delivery including socket cap screws
DIN EN ISO 4762 and pins
DIN EN ISO 8735



2664.11.02

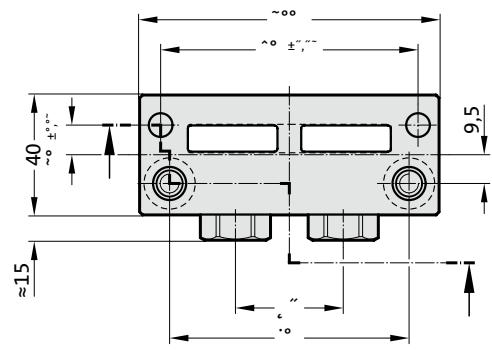
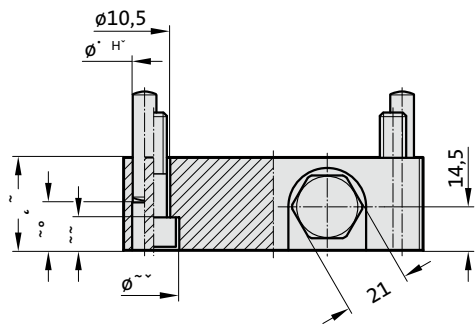

Material:

HWS (1.2379)
Hardness 60 +2 HRC

Note:

Delivery including socket cap screws
DIN EN ISO 4762 and pins
DIN EN ISO 8735



Retainer BOLT LOCK

2664.11.03

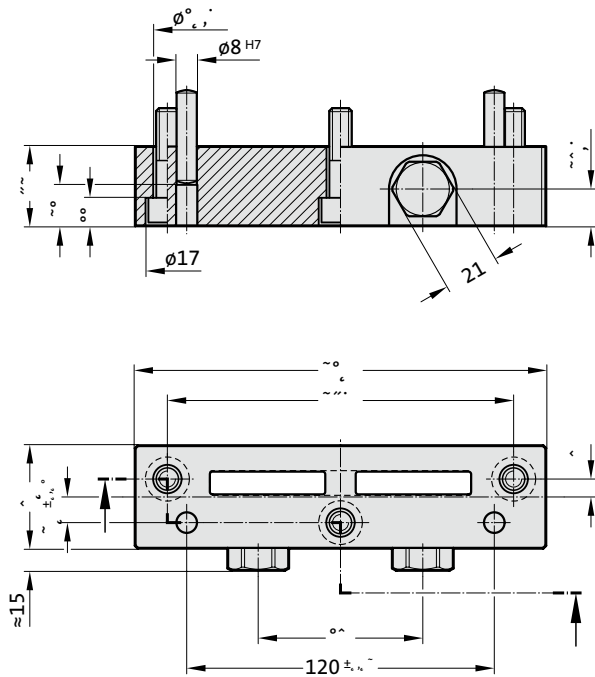

Material:

HWS (1.2379)
Hardness 60 +2 HRC

Note:

Delivery including socket cap screws
DIN EN ISO 4762 and pins
DIN EN ISO 8735



2664.11.04

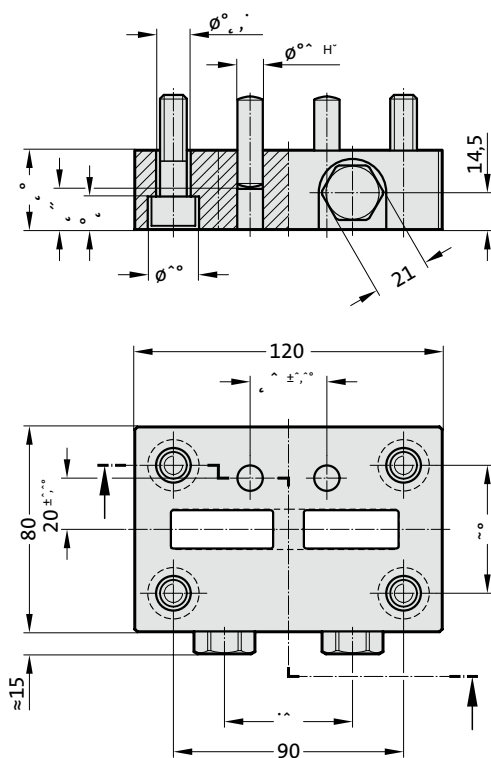

Material:

HWS (1.2379)
Hardness 60 +2 HRC

Note:

Delivery including socket cap screws
DIN EN ISO 4762 and pins
DIN EN ISO 8735



Retainer BOLT LOCK



2664.11.05

Material:

HWS (1.2379)
Hardness 60 +2 HRC

Note:

Delivery including socket cap screws
DIN EN ISO 4762 and pins
DIN EN ISO 8735

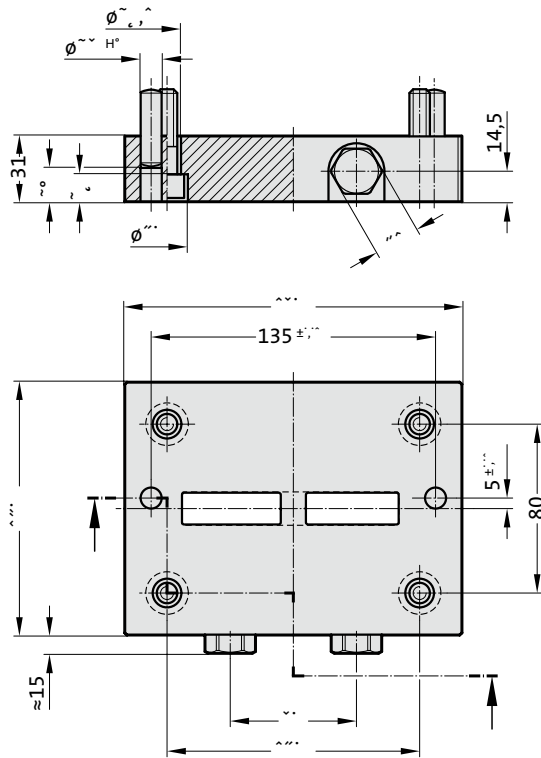

2664.11.06

Material:

HWS (1.2379)
Hardness 60 +2 HRC

Note:

Delivery including socket cap screws
DIN EN ISO 4762 and pins
DIN EN ISO 8735

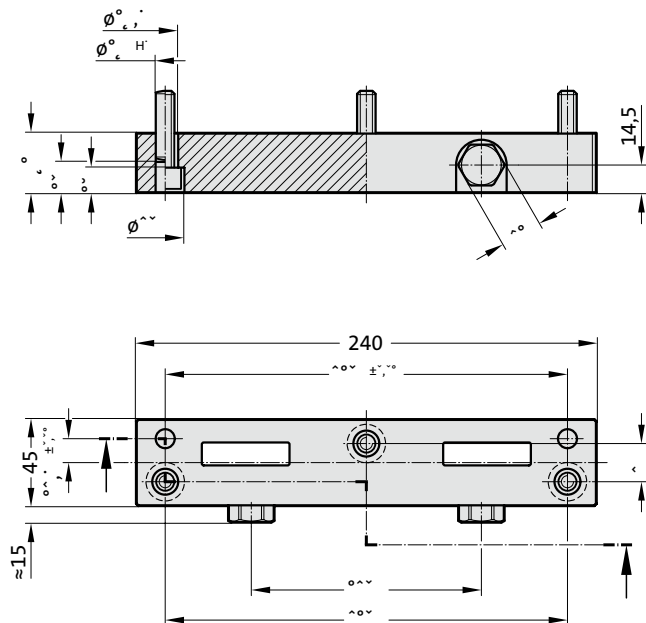



Retainers for punches ISO 8020



Triangle retainer, for punches ISO 8020 without anti-rotation element

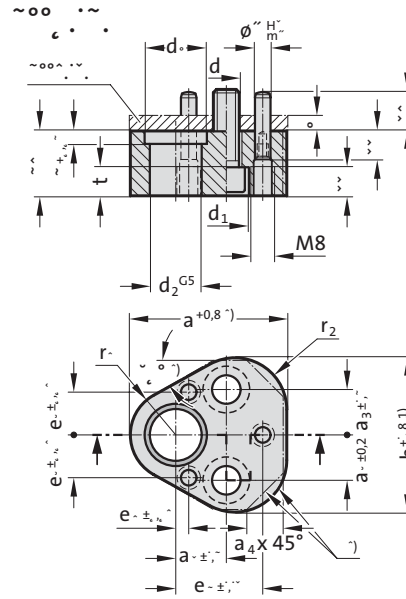

Execution:

The centres of the pinholes are the reference points for the position of the punch bore.

The dimensions e_1 , e_2 and e_3 have a tolerance of ± 0.01 mm.

The triangle ball-lock retainers are interchangeable.

Note:

Pressure plate 2665.01. to be ordered separately for the receiving punch plate.

1) Contours may vary. Maximum dimensions are specified in the table.



2664.02. Triangle retainer, for punches ISO 8020 without anti-rotation element

Order No	d	d ₁	d ₂	d ₃	a	a ₁	a ₃	a ₄	b	e ₁	e ₂	e ₃	t	r ₁	r ₂
2664.02.10	9	15	10	14	44.5	19	11.1	10	43.7	7.5	26.925	9	9	9.5	12
2664.02.13	9	15	13	17	50.8	19	14.3	12	50	6.5	29.97	12	9	12.7	15.2
2664.02.16	9	15	16	20	54	19	15.9	13	53.2	6	31.75	13.5	9	14.3	16.8
2664.02.20	11	18	20	24	60.3	19	17.5	14	59.5	5	33.53	16.5	11	17.5	20
2664.02.25	13.5	20	25	29	69.9	23.8	19.8	16	69.1	7	40.64	22	13.5	22.2	24.7
2664.02.32	13.5	20	32	36	69.9	23.8	19.8	16	69.1	7	40.64	22	13.5	22.2	24.7

Triangle retainer, for punches ISO 8020 with anti-rotation element

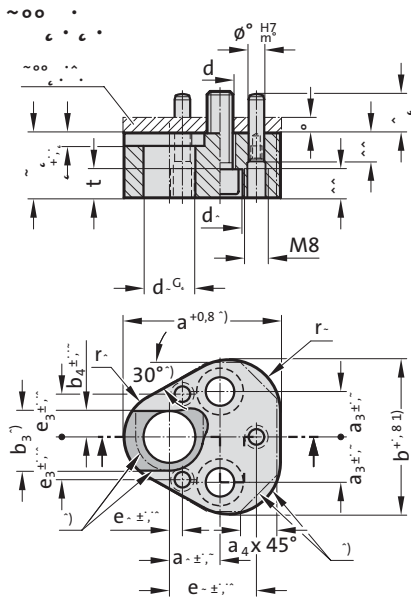

Execution:

The centres of the pinholes are the reference points for the position of the punch bore.

The dimensions e_1 , e_2 and e_3 have a tolerance of ± 0.01 mm.

The triangle ball-lock retainers are interchangeable.

Note:

Pressure plate 2665.01. to be ordered separately for the receiving punch plate.

1) Contours may vary. Maximum dimensions are specified in the table.



2664.04. Triangle retainer, for punches ISO 8020 with anti-rotation element

Order No	d	d ₁	d ₂	a	a ₁	a ₃	a ₄	b	b ₃	b ₄	e ₁	e ₂	e ₃	t	r ₁	r ₂
2664.04.10	9	15	10	44.5	19	11.1	10	43.7	12	5	7.5	26.925	9	9	9.5	12
2664.04.13	9	15	13	50.8	19	14.3	12	50	15	6.5	6.5	29.97	12	9	12.7	15.2
2664.04.16	9	15	16	64	19	15.9	13	53.2	18	8	6	31.75	13.5	9	14.3	16.8
2664.04.20	11	18	20	60.3	19	17.5	14	59.5	23	10	5	33.53	16.5	11	17.5	20
2664.04.25	13.5	20	25	69.9	23.8	19.8	16	69.1	28	12.5	7	40.64	22	13.5	22.2	24.7
2664.04.32	13.5	20	32	69.9	23.8	19.8	16	69.1	35	16	7	40.64	22	13.5	22.2	24.7



Accessories for Retainers, triangular, for Punches, to ISO 8020

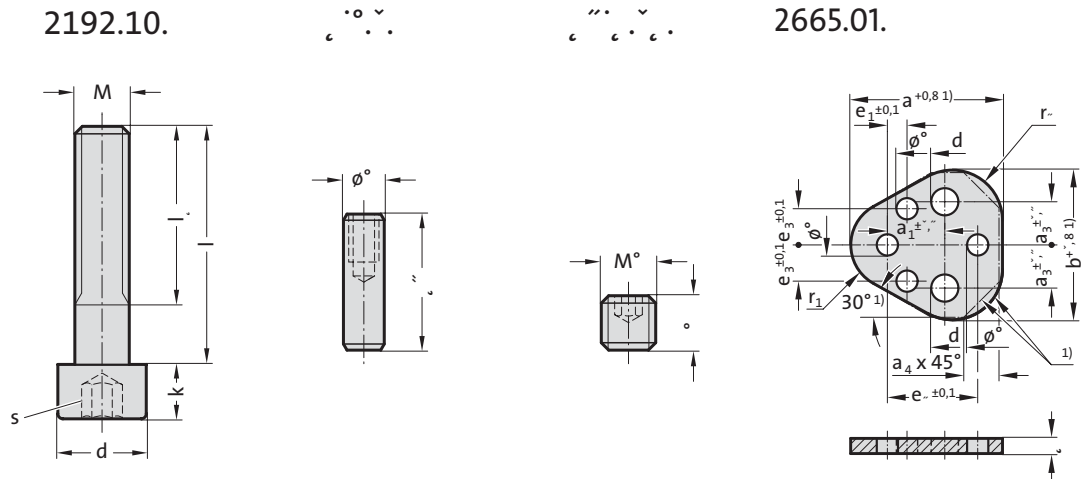

Retainer	ϕd_2	Socket head cap screw	Dowel pin	Pin screw	Pressure plate
2664.02./04.	10	2192.10.08.035	236.1.0600.020	2192.72.08.008	2665.01.10
	13	2192.10.08.035	236.1.0600.020	2192.72.08.008	2665.01.13
	16	2192.10.08.035	236.1.0600.020	2192.72.08.008	2665.01.16
	20	2192.10.10.035	236.1.0600.020	2192.72.08.008	2665.01.20
	25	2192.10.12.035	236.1.0600.020	2192.72.08.008	2665.01.25
	32	2192.10.12.035	236.1.0600.020	2192.72.08.008	2665.01.32

Accessories



Stripping unit



2431.7.

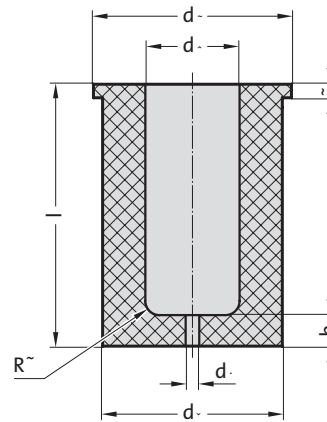

Installation example:

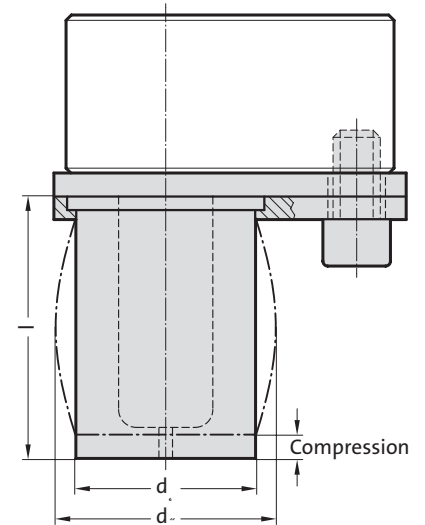

Material:

FIBROFLEX® 95 Shore A

Note:

Stripping units can be used for retainers 2664.02./04./05./06./10.

* values for the stripping force are dependent on a number of parameters (e.g. lubricant, temperature etc.) and may vary from those given here.

** max spring travel should not exceed 15% of the length

2431.7. Stripping unit

d ₂	d ₁	d ₃	d ₄	d _{5 max.}	b	Stripping unit length l					
						35	43	53	63	73	
10	18	21	1,6	22	6	○	●	●	●		
13	23	26	3	26,5	6	○	●	●	●	●	
16	28	31	3	34	6	○	●	●	●	●	
20	33	36	3	38	7	○	●	●	●	●	
25	40	43	3	47,6	7	○	●	●	●	●	
32	50	55	3	57,9	7	○	●	●	●	●	
38	60	65	3	69,6	8		○	○	○	○	
40	60	65	3	69,6	8		●	●	●	○	
						Punch lengths in use					
						Ball-lock punch, light duty	63	71	80	90	100
						Ball-lock punch, heavy duty	71	80	90	100	110
						Precision punch ISO 8020	-	71	80	90	100
						○ = Special measures upon request					

Spring travel**	3 mm			6 mm			9 mm			3 mm			6 mm			9 mm		
	Length	35	35	35	43	43	43	53	53	53	63	63	63	73	73	73	73	
d ₂	Stripping forces (N)*																	
10	1300	-	-	1060	1820	-	900	1650	-	720	1450	1860	-	-	-	-	-	
13	2100	-	-	1700	2850	-	1460	2610	-	1170	2320	2910	930	2080	2500			
16	3000	-	-	2310	3900	-	1990	3560	-	1590	3150	3980	1270	2810	3440			
20	3500	-	-	2900	4900	-	2500	4470	-	2000	3950	5000	1590	3420	4330			
25	5400	-	-	4440	7520	-	3810	6860	-	3050	6050	7680	2420	5390	6780			
32	8400	-	-	6840	11390	-	5880	10450	-	4700	9310	11640	3740	8370	10280			
38	-	-	-	9280	19740	-	8140	15890	-	6440	11570	18030	5460	8850	11680			
40	-	-	-	10100	20190	-	8650	17300	-	6890	13780	20670	6000	9800	12700			

Ordering example:

Stripping unit	=	2431.7.
d ₂ = 10 mm	=	10.
l = 53 mm	=	53
Order number	=	2431.7.10.53

Stripping unit - Pressure plate



~∞ ∙

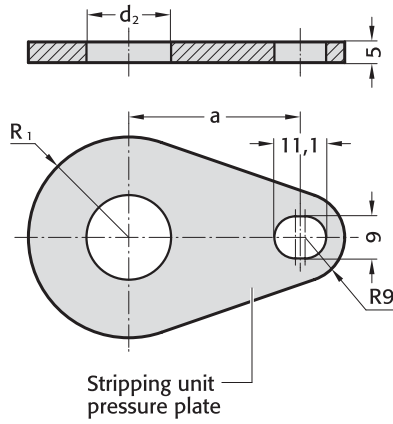

2667.1. Stripping unit - Pressure plate

Order No	d ₂	R ₁	a
2667.1.10	10	13	28
2667.1.13	13	15.5	31
2667.1.16	16	18	32.9
2667.1.20	20	20.5	34.8
2667.1.25	25	24	39.8
2667.1.32	32	31	41.3
2667.1.38	38	36	45
2667.1.40	40	36	45

Note:

Pressure plate, mounting plate and screw must all be ordered individually.

Mounting example

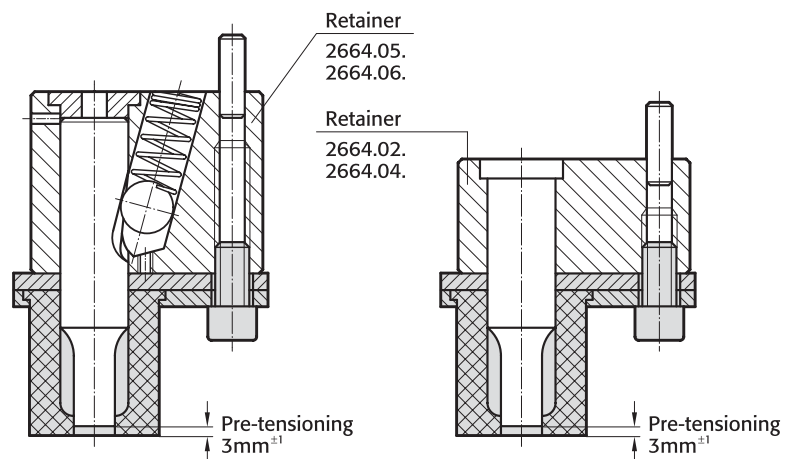

Stripping unit - Mounting plate



2667.2.

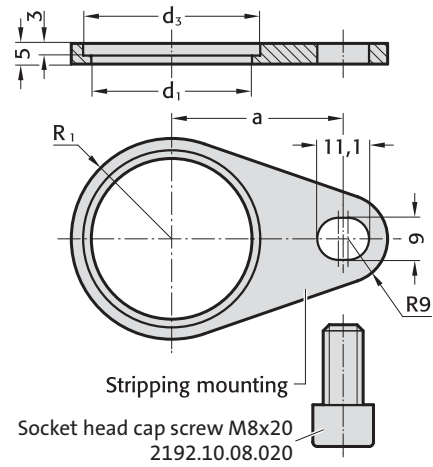

Note:

Pressure plate, mounting plate and screw must all be ordered individually.

2667.2. Stripping unit - Mounting plate

Order No	d ₂	d ₁	d ₃	R ₁	a
2667.2.10	10	19	22	13	28
2667.2.13	13	24	27	15.5	31
2667.2.16	16	29	32	18	32.9
2667.2.20	20	34	37	20.5	34.8
2667.2.25	25	41	44	24	39.8
2667.2.32	32	51	56	31	41.3
2667.2.38	38	61	66	36	45
2667.2.40	40	61	66	36	45

Mounting example

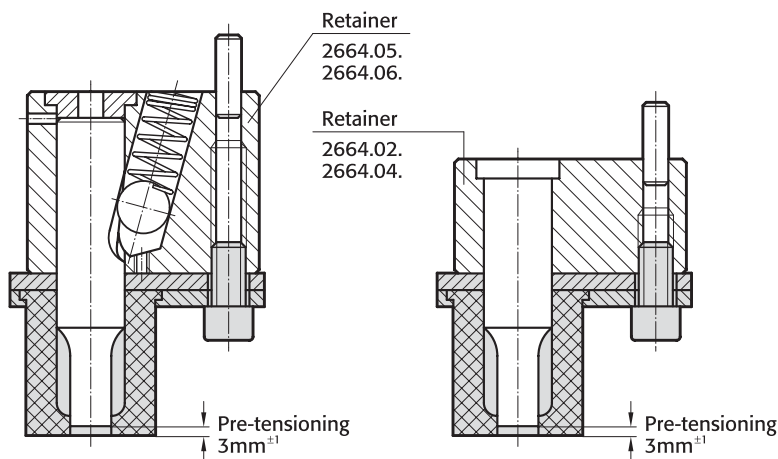

Elastomer Stripper



Mounting example

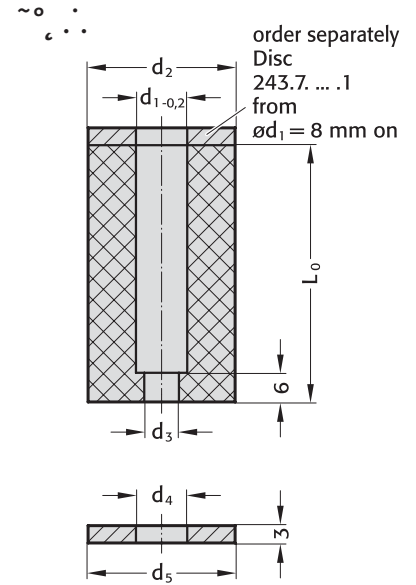
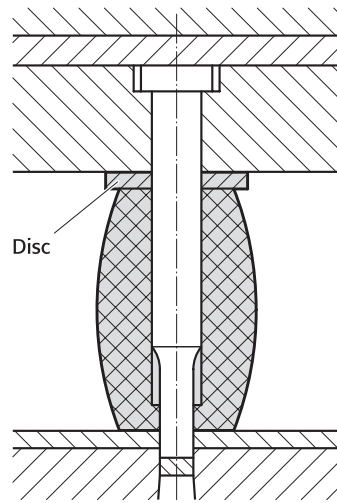

Description:

Repairs, sharpening and modifications on dies equipped with elastomer strippers do not necessitate the dismantling of a stripper plate, thus becoming very expedient.

Any marring of delicate part surfaces is precluded. This makes elastomer strippers ideal for all painted, anodized, plastic-coated and polished parts. FIBROFLEX® Elastomer Strippers are resistant against oils and greases.

Material:

FIBROFLEX®
Hardness: 95 Shore A

Execution:

Stock lengths: 39, 47, 56 mm.
Other lengths on request (max. 56 mm)!

Application:

Especially in large dies, where the use of elastomer strippers does away with the need of huge stripper plates.

Mounting:

Push stripper over punch, where it will stay put on account of its elasticity.

No other form of retention will be required.

A single press stroke will then pierce a hole through the bottom portion of the stripper that matches the punch shape exactly.

243.7. Elastomer Stripper

d ₁	d ₂	d ₃	L ₀	39	47	56
4	17	1.6		●	●	●
5	17	1.6		●	●	●
6	19	1.6		●	●	●
6.3	19	1.6		●	●	●
8	21	3		●	●	●
10	23	3		●	●	●
12.5	26	3		●	●	●
13	26	3		●	●	●
16	30	3		●	●	●
20	38	3		●	●	●
25	50	3		●	●	●
32	55	3		●	●	●
38	60	3		●	●	●
40	63	3		●	●	●

Ordering Code (example):

Elastomer Stripper	=243.7.
Inside diameter d ₁ 4 mm	= 040.
Length L ₀ 39 mm	= 039
Order No	=243.7. 040. 039

Washer



243.7. .1

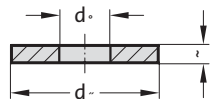

Material:

Steel

243.7. .1 Washer

Order No	d_4	d_5
243.7.085.1	8.5	21
243.7.105.1	10.5	23
243.7.130.1	13	26
243.7.135.1	13.5	26
243.7.165.1	16.5	30
243.7.205.1	20.5	38
243.7.255.1	25.5	50
243.7.325.1	32.5	55
243.7.385.1	38.5	60
243.7.405.1	40.5	63

Special Punches, Custom made
High-Precision Special Parts to Customer's Drawings



FIBRO manufactures Special Form Punches and -Matrices on most modern equipment. Projection Form Grinding, Creep Feed Grinding, EDM and Wire-EDM are used acc. to design details.

Many years of experience enable FIBRO to chose best suitable materials and methods.

We manufacture to customer's drawings:

- Piercing Punches
- Draw Punched
- Form Punches

- Pre-Extrusion Punches and Ejectors for Bolt Manufacturing
- Flow-Forming Punches
- Punches with 30°-Conical Heads or other head shapes



Punch without head, square / rectangular, Shape A



230.

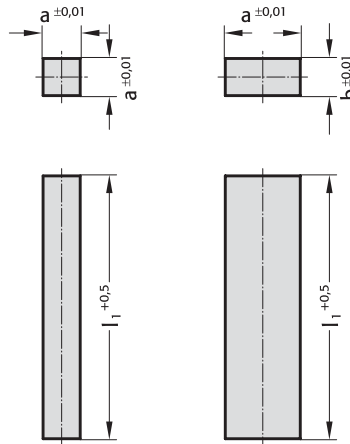

230. Punch without head, square / rectangular, Shape A

a	b	l_1	l^*
1 - 8	1	73.5	71
2 - 10	2	73.5	71
3 - 12	3	73.5	71
4 - 12	4	73.5	71
5 - 15	5	73.5	71
6 - 20	6	73.5	71
7 - 24	7	73.5	71
8 - 24	8	73.5	71
9 - 28	9	73.5	71
10 - 34	10	73.5	71
12 - 34	12	73.5	71

* l = Nominal ordering length

Material:

HSS
 Order No 230.3.
 Hardness:
 Shaft 64 ± 2 HRC

Description of FIBRO materials for tool and die components see at the beginning of Chapter E.

Execution:

Punch shaft precision ground.

l_1 : Stock length of square punches: 73,5 mm
 Other materials and dimensions on request.

Ordering Code (example):

Punch without head, square / rectangular, Shape A	= 230.
Material MAT	HSS = 3.
Punch cutting length a	1 mm = 0100.
Punch cutting width b	1 mm = 0100.
Nominal ordering length l	71 = 071
Order No	= 230. 3. 0100. 0100. 071

Punch with head, square / rectangular, Shape B



~
c .

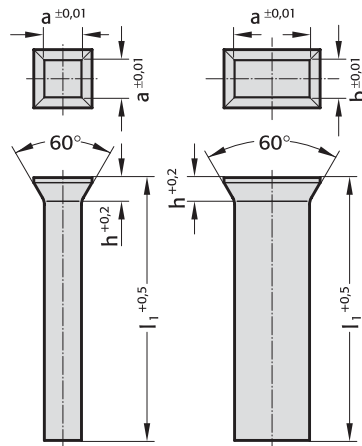

Material:

HSS
Order No 231.3.
Hardness:
Shaft 64 ± 2 HRC
Head $52 \pm$ HRC

Description of FIBRO materials for tool and die components see at the beginning of Chapter E.

Execution:

Punch shaft precision ground.
Heads hot upset forged - ground on special request.

l_1 : Stock length of square punches: 71 mm
Other materials and dimensions on request.

231. Punch with head, square / rectangular, Shape B

a	b	h	l_1
1 - 8	1	1.2	71
2 - 10	2	1.4	71
3 - 12	3	1.8	71
4 - 12	4	1.8	71
5 - 15	5	1.8	71
6 - 20	6	2	71
7 - 24	7	2.8	71
8 - 24	8	2.8	71
9 - 28	9	2.8	71
10 - 34	10	2.8	71
12 - 34	12	2.8	71

Ordering Code (example):

Punch with head, square / rectangular, Shape B	= 231.
Material MAT	HSS = 3.
Punch cutting length a	1 mm = 0100.
Punch cutting width b	1 mm = 0100.
Length l_1	71 mm = 071
Order No	= 231. 3. 0100. 0100. 071

DOWEL PIN WITH INTERNAL EXTRACTING THREAD, SIMILAR TO DIN EN ISO 8735



236.1.

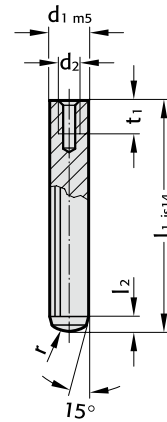

Material:

Steel
Hardness 60 ± 2 HRC

Execution:

hardened and ground to finest finish
FIBRO Dowel Pins are manufactured with the exacting requirements of high class diemaking in mind. Whereas DIN EN ISO 8735 stipulates ISO Class 6 for dowels, we produce our pins to m5.

236.1. Dowel pin with internal extracting thread, similar to DIN EN ISO 8735

d ₁	d ₂	t ₁	l ₂	r	l ₁	16	18	20	24	28	32	36	40	45	50	55	60	70	80	90	100	120
6	M4	6	2.1	6		•	•	•	•	•	•	•	•	•	•	•	•					
8	M5	8	2.6	8				•	•	•		•	•	•	•	•	•	•	•	•	•	•
10	M6	10	3	10					•	•	•	•	•	•	•	•	•	•	•	•	•	•
12	M6	12	3.8	12						•	•	•	•	•	•	•	•	•	•	•	•	•
14	M8	12	4	16							•	•	•	•	•	•	•	•	•	•	•	•
16	M8	16	4.7	16							•	•	•	•	•	•	•	•	•	•	•	•
20	M10	20	6	20								•	•	•	•	•	•	•	•	•	•	•
25	M16	24	6	25									•	•	•	•	•	•	•	•	•	•

Ordering Code (example):

Dowel pin with internal extracting thread, similar to DIN EN ISO 8735	=	236.1.
Diameter d ₁	14 mm =	1400.
Length l ₁	32 mm =	032
Order No	=	236.1. 1400. 032

DOWEL PIN WITH INTERNAL EXTRACTING THREAD, ACCORDING TO DIN EN ISO 8735

2361.1.

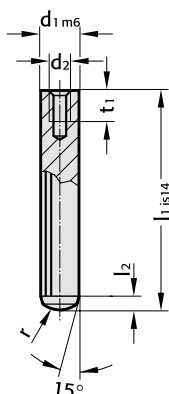

Material:

Steel
Hardness 60 ± 2 HRC

Execution:

hardened and ground to finest finish

2361.1. Dowel pin with internal extracting thread, according to DIN EN ISO 8735

d ₁	d ₂	t ₁	l ₂	r	l ₁	8	10	12	14	16	18	20	22	24	26	28	30	32	36	40	45	50	55	60	70	80	90	100	120
4	M2,5	4.5	1.3	4			•	•	•	•	•	•	•	•	•	•	•	•	•	•	•	•	•	•	•	•	•	•	•
5	M3	5	1.7	5		•	•	•	•	•	•	•	•	•	•	•	•	•	•	•	•	•	•	•	•	•	•	•	•
6	M4	6	2.1	6				•	•	•	•	•	•	•	•	•	•	•	•	•	•	•	•	•	•	•	•	•	•
8	M5	8	2.6	8					•	•	•	•	•	•	•	•	•	•	•	•	•	•	•	•	•	•	•	•	•
10	M6	10	3	10						•	•	•	•	•	•	•	•	•	•	•	•	•	•	•	•	•	•	•	•
12	M6	10	3.8	12							•	•	•	•	•	•	•	•	•	•	•	•	•	•	•	•	•	•	•
14	M8	12	4	14								•	•	•	•	•	•	•	•	•	•	•	•	•	•	•	•	•	•
16	M8	12	4.7	16									•	•	•	•	•	•	•	•	•	•	•	•	•	•	•	•	•
20	M10	16	6	20										•	•	•	•	•	•	•	•	•	•	•	•	•	•	•	•

Ordering Code (example):

Dowel pin with internal extracting thread, according to DIN EN ISO 8735	=	2361.1.
Diameter d ₁	10 mm =	1000.
Length l ₁	16 mm =	016
Order No	=	2361.1. 1000. 016

FIBROZIPP

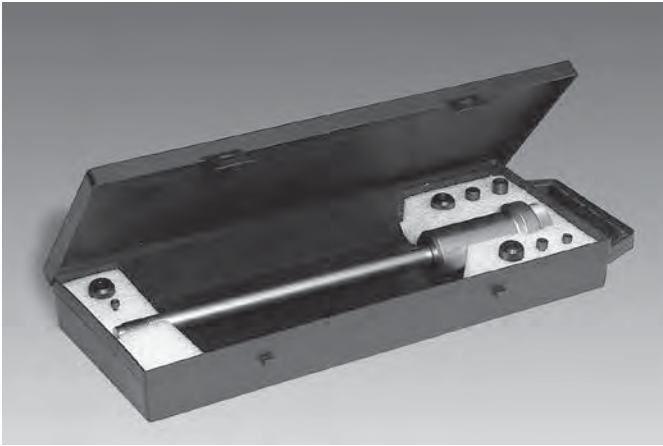

236.001 Do wel Pin Extractor FIBROZIPP

Extraction tool for the fast and convenient removal of dowels with internal extracting thread – also for shafts, plugs and other machine components.

The tool comes with interchangeable adaptors and screws, to fit all threads from M3 to M16.

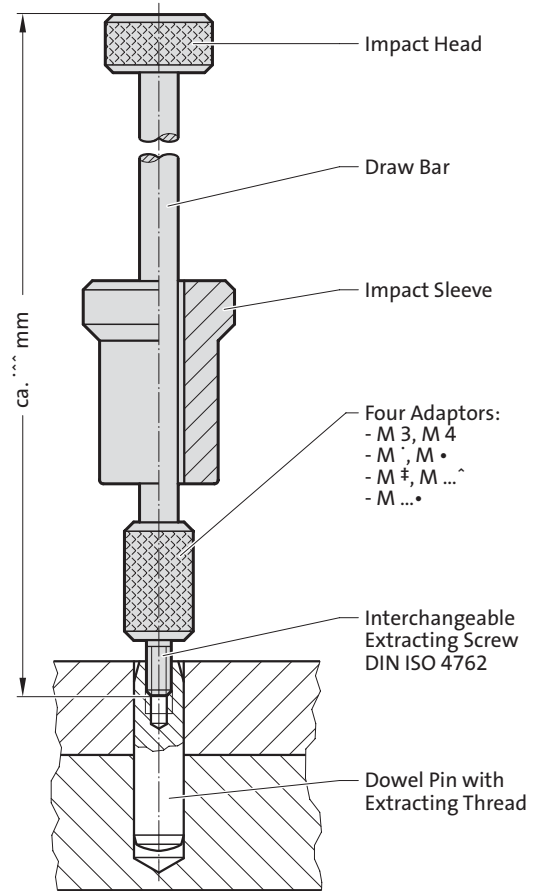



Liner bush for dowel pin, for bonding

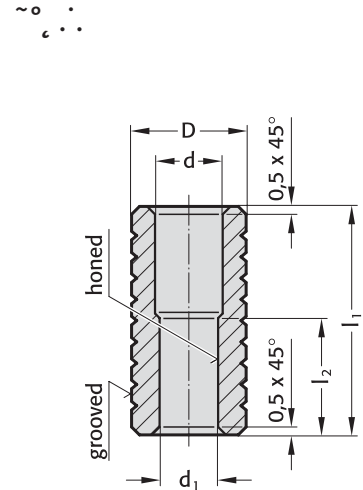
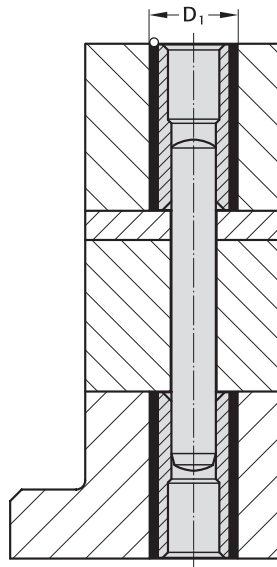

Description:

Dowel liner bushes are used where precisely positioned, unhardened parts are often changed or must be replaced, e.g. in precision tool construction.

Material:

WS
Hardness 54 ± 2 HRC

Epoxy-Bonding:

The jig-ground pin holes of the hardened matrix are joined with the dowel liner bush by means of a dowel pin 235.1. Retainer holes for dowel liner bushes should be approximately 2 mm larger in diameter than the bush O.D. – a coarse finish is desirable. Following exact positioning/aligning, FIBROLIT® ZWO or FIBROFIX® SECHS is used for bonding.

265.1. Liner bush for dowel pin, for bonding

d_1	d	D	D_1	l_1	l_2
6	7	10	12	25	12
8	9	12	14	30	16
10	11	16	18	36	20

Ordering Code (example):

One Dowel Liner Bush – only –	
Dowel Liner Bush	= 265.
Material: Tool Steel	= 1.
$d_1 = \varnothing 8,0$ mm	= 0800.
Quantity: one	= 1
Order No	= 265.1.0800.1

Ordering Code (example):

One Dowel Liner Bush + Matching Dowel	
Dowel Liner Bush	= 265.
Material: Tool Steel	= 1.
$d_1 = \varnothing 8,0$ mm	= 0800.
Quantity: one	= 1.
Dowel: length = 40 mm	= 040
Order No	= 265.1.0800.1.040

Ordering Code (example):

Two Dowel Liner Bushes + one Dowel	
Dowel Liner Bush	= 265.
Material: Tool Steel	= 1.
$d_1 = \varnothing 8,0$ mm	= 0800.
Quantity: two	= 2.
Dowel: length = 50 mm	= 050
Order No	= 265.1.0800.2.050



Liner bush for dowel pin, for push fit

~ ° ~ ° ~

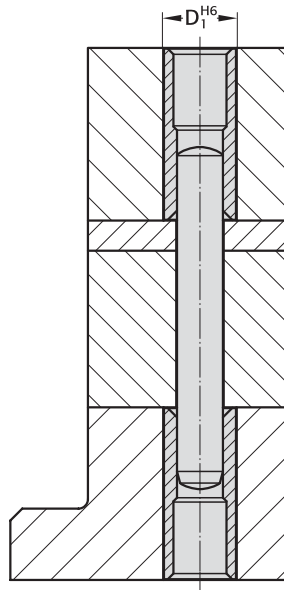
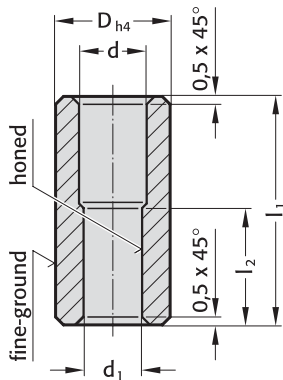

Description:

Dowel liner bushes are used where precisely positioned, unhardened parts are often changed or must be replaced, e.g. in precision tool construction.

Material:

WS
Hardness 54 ± 2 HRC

Slip-Fit Bonding:

The position of the bush is given by push fit hole tolerance H6. The adhesive (order no. 281.648) provides optimum push retention whilst offering the following

advantages:

- high accuracy and stiffness
- no problems to find position when changing bushings

We do not recommend to press fit bushings.

2650.1. Liner bush for dowel pin, for push fit

d ₁	d	D	l ₁	l ₂
6	7	10	25	12
8	9	12	30	16
10	11	16	36	20

Ordering Code (example):

One Dowel Liner Bush – only –

Dowel Liner Bush	=	2650.
Material: Tool Steel	=	1.
d ₁ = ∅ 8,0 mm	=	0800.
Quantity: one	=	1
Order No	=	2650.1.0800.1

Ordering Code (example):

One Dowel Liner Bush + Matching Dowel

Dowel Liner Bush	=	2650.
Material: Tool Steel	=	1.
d ₁ = ∅ 8,0 mm	=	0800.
Quantity: one	=	1.
Dowel: length = 40 mm	=	040
Order No	=	2650.1.0800.1.040

Ordering Code (example):

Two Dowel Liner Bushes + one Dowel

Dowel Liner Bush	=	2650.
Material: Tool Steel	=	1.
d ₁ = ∅ 8,0 mm	=	0800.
Quantity: two	=	2.
Dowel: length = 50 mm	=	050
Order No	=	2650.1.0800.2.050



DOWEL PIN SIMILAR TO DIN EN ISO 8734

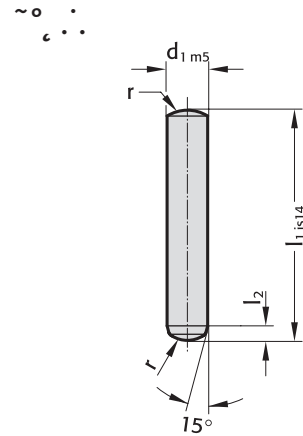

Material:

Steel
Hardness 60 ± 2 HRC

Execution:

hardened and ground to finest finish
FIBRO Dowel Pins are manufactured with the exacting requirements of high class diemaking in mind. Whereas DIN EN ISO 8734 stipulates ISO Class 6 for dowels, we produce our pins to m5.

235.1. Dowel pin similar to DIN EN ISO 8734

d ₁	l ₂	r	l ₁	6	8	10	12	14	16	18	20	24	28	32	36	40	45	50	55	60	70	80	90	100	120	130	140	
1	0.48	1			•	•	•																					
1.5	0.62	1.6		•	•	•	•	•	•																			
2	0.78	2		•	•	•	•	•	•	•	•	•	•	•	•													
2.5	0.95	2.5		•	•	•	•	•	•	•	•	•	•	•	•	•												
3	1.1	3		•	•	•	•	•	•	•	•	•	•	•	•	•	•											
4	1.4	4		•	•	•	•	•	•	•	•	•	•	•	•	•	•	•										
5	1.7	5			•	•	•	•	•	•	•	•	•	•	•	•	•	•	•	•								
6	2.1	6				•	•	•	•	•	•	•	•	•	•	•	•	•	•	•	•	•	•	•	•	•	•	•
8	2.6	8					•	•	•	•	•	•	•	•	•	•	•	•	•	•	•	•	•	•	•	•	•	•
10	3	10							•	•	•	•	•	•	•	•	•	•	•	•	•	•	•	•	•	•	•	•
12	3.8	12								•	•	•	•	•	•	•	•	•	•	•	•	•	•	•	•	•	•	•
14	3.8	16													•	•	•	•	•	•	•	•	•	•	•	•	•	•
16	4.7	16														•	•	•	•	•	•	•	•	•	•	•	•	•
20	6	20															•	•	•	•	•	•	•	•	•	•	•	•

Ordering Code (example):

Dowel pin similar to DIN EN ISO 8734	=	235.1.
Diameter d ₁	6 mm	= 0600.
Length l ₁	10 mm	= 010
Order No		= 235.1.0600. 010

Dowel pin according to DIN EN ISO 8734



~° " " "

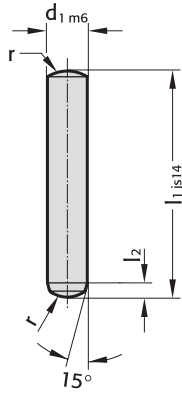

Material:

Steel
Hardness 60 ± 2 HRC

Execution:

hardened and ground to finest finish

2351.1. Dowel pin according to DIN EN ISO 8734

d ₁	l ₂	r	l ₁	4	5	6	8	10	12	14	16	18	20	22	24	26	28	30	32	36	40	45	50	55	60	70	80	90	100	120
1	0.4	1		•	•	•	•	•	•	•	•	•	•	•	•	•	•	•	•	•	•	•	•	•	•	•	•	•	•	•
1.5	0.5	1.6		•	•	•	•	•	•	•	•	•	•	•	•	•	•	•	•	•	•	•	•	•	•	•	•	•	•	•
2	0.6	2		•	•	•	•	•	•	•	•	•	•	•	•	•	•	•	•	•	•	•	•	•	•	•	•	•	•	•
2.5	0.7	2.5		•	•	•	•	•	•	•	•	•	•	•	•	•	•	•	•	•	•	•	•	•	•	•	•	•	•	•
3	0.8	3		•	•	•	•	•	•	•	•	•	•	•	•	•	•	•	•	•	•	•	•	•	•	•	•	•	•	•
4	1	4		•	•	•	•	•	•	•	•	•	•	•	•	•	•	•	•	•	•	•	•	•	•	•	•	•	•	•
5	1.2	5		•	•	•	•	•	•	•	•	•	•	•	•	•	•	•	•	•	•	•	•	•	•	•	•	•	•	•
6	1.5	6		•	•	•	•	•	•	•	•	•	•	•	•	•	•	•	•	•	•	•	•	•	•	•	•	•	•	•
8	1.8	8		•	•	•	•	•	•	•	•	•	•	•	•	•	•	•	•	•	•	•	•	•	•	•	•	•	•	•
10	2	10		•	•	•	•	•	•	•	•	•	•	•	•	•	•	•	•	•	•	•	•	•	•	•	•	•	•	•
12	2.5	12		•	•	•	•	•	•	•	•	•	•	•	•	•	•	•	•	•	•	•	•	•	•	•	•	•	•	•
14	2.5	16		•	•	•	•	•	•	•	•	•	•	•	•	•	•	•	•	•	•	•	•	•	•	•	•	•	•	•
16	3	16		•	•	•	•	•	•	•	•	•	•	•	•	•	•	•	•	•	•	•	•	•	•	•	•	•	•	•
20	4	20		•	•	•	•	•	•	•	•	•	•	•	•	•	•	•	•	•	•	•	•	•	•	•	•	•	•	•

Ordering Code (example):

Dowel pin according to DIN EN ISO 8734	= 2351.1.
Diameter d ₁	1 mm = 0100.
Length l ₁	4 mm = 004
Order No	= 2351.1. 0100. 004



DRILL BUSH WITH COLLAR, DIN 172 SHAPE A



~o
c.

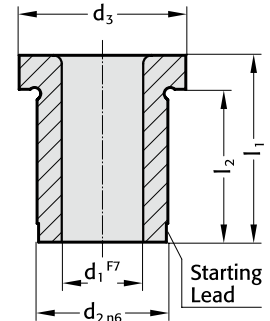

Material:

Case hardened steel
Hardness 740 ± 40 HV 10

Execution:

Diameters d_1 , d_2 and shoulder precision ground.

276. Drill bush with collar, DIN 172 Shape A

d_1	d_2	d_3	Gradation	l_1	6	8	9	10	12	16	20	25	28	30	36	45	56	67
0,9 - 1	3	6	0.1	l_2	4		7											
1,1 - 1,8	4	7	0.1		4		7											
1,9 - 2,6	5	8	0.1		4		7											
2,7 - 3,3	6	9	0.1			5.5			9.5	13.5								
3,4 - 4	7	10	0.1			5.5			9.5	13.5								
4,1 - 5	8	11	0.1			5.5			9.5	13.5								
5,1 - 6	10	13	0.1				7			13	17							
6,1 - 8	12	15	0.1				7			13	17							
8,1 - 10	15	18	0.1					9			17	22						
10,1 - 12	18	22	0.1					8			16	21						
12,1 - 15	22	26	0.1							12			24		32			
15,5 - 18	26	30	0.5							12			24		32			
18,5 - 22	30	34	0.5								15				31	40		
22,5 - 26	35	39	0.5								15				31	40		
26,5 - 30	42	46	0.5									20				40	51	
30,5 - 35	48	52	0.5									20				40	51	
35,5 - 42	55	59	0.5											25			51	62

Ordering Code (example):

Drill bush with collar, DIN 172 Shape A = 276.1.

diameter of conduit d_1 12.1 mm = 1210.

Length l_1 16 mm = 016

Order No = 276.1. 1210.016

DRILL BUSH WITHOUT COLLAR, DIN 179 SHAPE A



~∞.

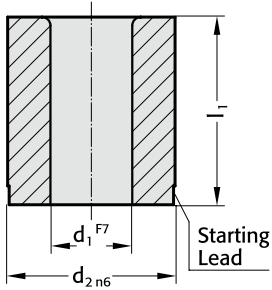

Material:

Case hardened steel

Hardness 740 ± 40 HV 10

Execution:

Diameters d_1 and d_2 precision ground.

277. Drill bush without collar, DIN 179 Shape A

d_1	d_2	Gradation	l_1	6	8	9	10	12	16	20	25	28	30	36	45	56	67
0,9 - 1	3	0.1		●		●											
1,1 - 1,8	4	0.1		●		●											
1,9 - 2,6	5	0.1		●		●											
2,7 - 3,3	6	0.1			●			●	●								
3,4 - 4	7	0.1			●			●	●								
4,1 - 5	8	0.1			●			●	●								
5,1 - 6	10	0.1					●	●	●								
6,1 - 8	12	0.1					●	●	●	●							
8,1 - 10	15	0.1					●	●	●	●	●						
10,1 - 12	18	0.1					●	●	●	●	●						
12,1 - 15	22	0.1						●	●	●	●	●					
15,5 - 18	26	0.5						●	●	●	●	●	●				
18,5 - 22	30	0.5							●	●	●	●	●	●			
22,5 - 26	35	0.5								●	●	●	●	●	●		
26,5 - 30	42	0.5									●	●	●	●	●	●	
30,5 - 35	48	0.5									●	●	●	●	●	●	
35,5 - 42	55	0.5										●	●	●	●	●	●
42,5 - 48	62	0.5											●	●	●	●	●

Ordering Code (example):

Drill bush without collar, DIN 179 Shape A	=	277.1.
diameter of conduit d_1	12.1 mm =	1210.
Length l_1	16 mm =	016
Order No	=	277.1. 1210.016

Gauge pin DIN 2269



$\sim \circ \therefore / \sim$

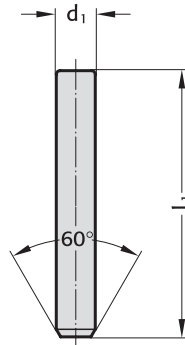

Material:

Alloy tool steel, hardened and tempered.
Age-treated repeatedly.
Hardness 60 ± 2 HRC

Execution:

precision ground
Quality class I: diameter tolerance $\pm 0,001$
Quality class II: diameter tolerance $\pm 0,002$

Single pins:

Quality class I 240.1.
Quality class II 240.2.

Small set:

91 gauge pins from \varnothing 1-10 mm in steps of 0,1 mm, complete in wooden box.
Quality class I 240.51.
Quality class II 240.52.

Large set:

273 gauge pins from \varnothing 1-10 mm in steps of 0,1 mm, plus one each. 0,01 mm-oversize/undersize pin – complete in wooden box
Quality class I 240.41.
Quality class II 240.42.

Special sets:

Supplied to customer's requirements in respect of assortment and quality class. All gauge pins from \varnothing 3 mm upward are marked with their actual size.

Ordering Code (example):

Gauge pin DIN 2269	=240.
Quality class KL	1 = 1.
Diameter d_1	0.29 mm = 0029
Order No	=240.1. 0029

240.1./2. Gauge pin DIN 2269

d_1	l_1
0.29 - 6	50
6.01 - 20	70

Direct gauging of bore diameters

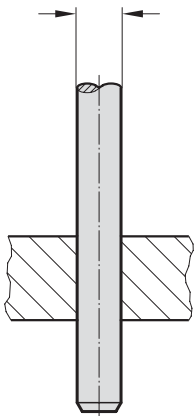

Measurement of centre-distance between two bores

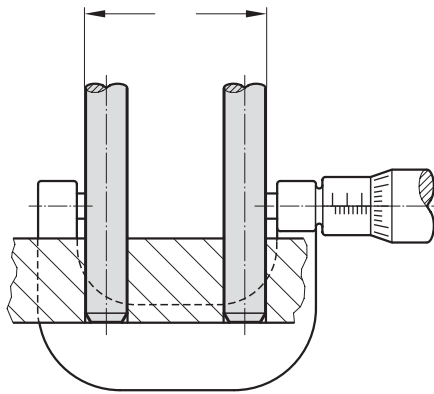

Concentricity check on a bush

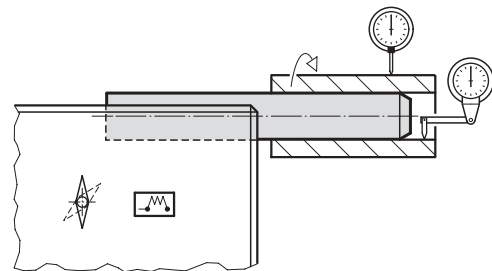

Measurements on prismatic faces

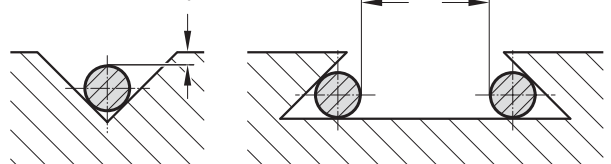



Gauge Pin Holders Wooden Boxes



Calibration of a comparator

Inspection for squareness of a bore

Check on parallelism

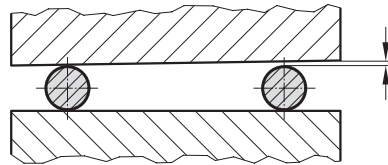
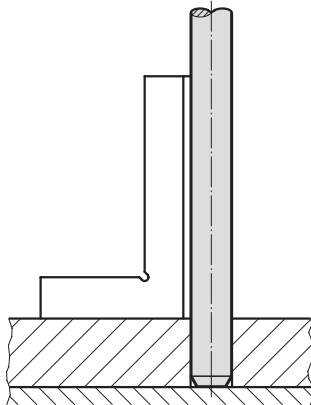
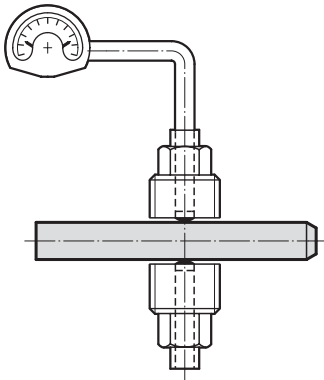

Measuring of gear teeth, threads etc.

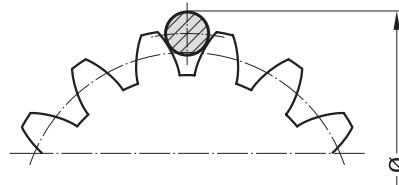

240.45. Gauge Pin Holders

(without pins)	for diameters	Order No
	from 1–2	240.45.1
	from 2–4	240.45.2
	from 4–6	240.45.3
	from 6–8	240.45.4
	from 8–10	240.45.5

Gauge Pin Holders are double-ended, to carry two pins e.g. for go – no go measurements etc.

Wooden boxes: (without pins)	with drilled holes, for the safe and orderly storage of gauge pins – each hole marked with the requisite pin size.	Order No
	Large Set of approx. 270 Pins size: 250 × 90 × 390	240.91
	Small Set of approx. 90 Pins size: 155 × 90 × 285	240.92
	Boxes complete with carrier board inset	
	Class I-Accuracy	240.9x.1
	Class II-Accuracy	240.9x.2

Ordering code (example):

Gauge pin box – approx. 270 pins	= 240.91.
Class I-Accuracy	= 1
Order No	= 240.91.1

High Precision Gauge Pin with Handle High Precision Gauge Pins – Boxed Sets



240.11./22.

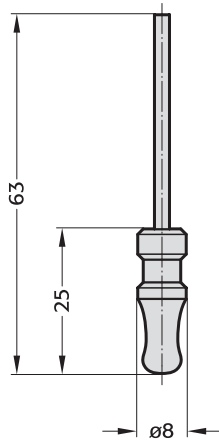

240.11./22. High-Precision Gauge Pin with Handle

The Gauge Pins are firmly fixed to the handle. Each Pin is marked with its true diameter.

Single Gauge Pins: \varnothing 0,3 – 3,0 mm, In dia. steps of 0.01 mm Order No

	Class I-Accuracy	240.11.				
	Class II-Accuracy	240.22.				
Assortment:	84 Gauge Pins from 0.3 – 3.0 mm, in dia. steps of 0.1 mm plus one each pin with undersize 0.01 and oversize 0.01 mm (for example 0.29 – 0.30 – 0.31 etc.)					
	Class I-Accuracy	240.31				
	Class II-Accuracy	240.32				
Special Assortments:	to customer's specifications in respect of class of accuracy					

Material:

Alloy tool steel, hardened and tempered.
Repeatedly age-treated.
Hardness 60 ± 2 HRC.
fine-ground
Class II-Accuracy ± 0.001
Class II-Accuracy ± 0.002
to DIN 2269

Ordering Code (example):

Gauge Pin	=	240.
Class I-Accuracy, with handle	=	11.
$d_1 = 1,5$ mm	=	0150
Order No	=	240.11.0150

Wooden box:

Wooden boxes for Gauge Pins – with drilled holes in wooden tray insert. Each hole marked with true size of pin.

External dimensions: 155x90x285 mm



Punching and embossing unit with matrix for punched holes and self tapping screws



Material:

HSS

Execution:

The punching and embossing unit with matrix consists of:

- 1 x embossing die
- 1 x punch die
- 1 x matrix

Sheet metal thickness:

max. 0,6 mm = 2282.01.035/039

max. 0,8 mm = 2282.01.042

max. 0,9 mm = 2282.01.048

max. 1,0 mm = 2282.01.055/063



2282.01. Punching and embossing unit with matrix for punched holes and self tapping screws

Order No	Nominal- \varnothing = thread size	d_1	d_2	d_{3h6}	d_{4k6}	d_{5h6}	d_6	d_7	d_{8h6}	d_{9k6}	l_1	l_2	l_3	l_4	l_5
2282.01.035	B 3,5	2.75	3.2	7.5	3.75	2.7	2.7	3.1	7.5	3.75	31.3	28	74.5	71.5	60
2282.01.039	B 3,9	3.05	3.4	7.5	3.75	3	3	3.6	7.5	3.75	31.3	28	74.5	71.5	60
2282.01.042	B 4,2	3.15	3.5	8.5	4.25	3.1	3.1	3.7	8	4	31.3	28	74.5	71.5	60
2282.01.048	B 4,8	3.85	4.2	9	4.5	3.8	3.8	4.5	8	4	31.3	28	74.5	71.5	60
2282.01.055	B 5,5	4.35	4.8	9	4.5	4.3	4.3	5	8	4	31.3	28	74.5	71.5	60
2282.01.063	B 6,3	4.85	5.3	10.5	5.25	4.8	4.8	5.5	10	5	31.3	28	74.5	71.5	60

2282.01.xxx

2282.01.xxx. Embossing die

2282.01.xxx.2 Punch die

2282.01.xxx.3 Bottom die

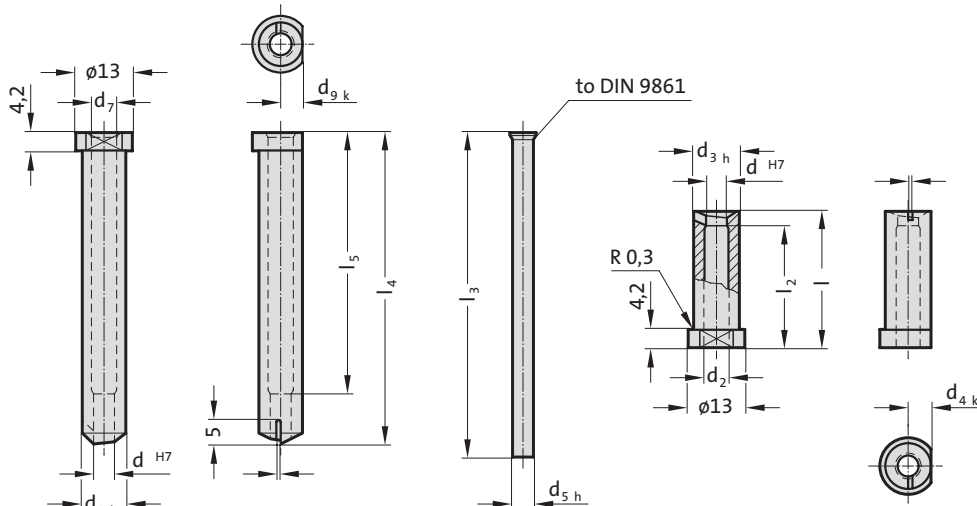

Example of application:

