



WE LOVE TECHNOLOGY



NC ROTARY TABLES  
WITH WORM GEAR UNIT  
**FIBROPLAN®**



ROTOCUTTING

Rotary Tables for Machine Tools

# WE MAKE PRODUCTION PROCESSES **MORE EFFICIENT**

Whatever the application, our rotary table technology combines maximum precision with enormous processing strength as well as the shortest cycle times, thus making your production processes more efficient.

Our rotary tables are deployed as swivelling & positioning axes, as workpiece carriers in machine tools and in the field of assembly work. Tens of thousands of rotary-table units around the globe are now integrated in high-productivity machines as major components. The quality, powerful technology and broad product range serve to satisfy our customers' requirements in the best possible way.

With its international position, FIBRO is your production partner, competent in resolving problems associated with rotary-table and NC applications across the globe. Our experts are available to assist you during and beyond the planning phase of your projects.



FIBRO ROTARY TABLES

# ROTARY TABLE RANGE FOR MACHINE TOOLS



FIBROPLAN®

**NC rotary tables with worm drive**

- All-rounder for the most diverse applications
- Available as single or multi-axis combination
- Transport loads up to 20 tons
- Ideal for circular milling and simultaneous machining
- Extremely broad range of table top diameters (160–3,000 mm)

**Your benefits**

- Worm drive (with adjustable play) for highest drive torques and lowest backlash
- Extremely low design for maximum operating area
- Design with force distribution optimisation for highest rigidity
- Pre-stressed axial/radial bearing for highest resistance to tilt and best axial runout accuracy and concentricity
- High-resolution encoder for excellent positioning accuracy (up to  $\pm 2''$ ) and repeat accuracy (up to  $\pm 0.25''$ )
- Hydraulic table top clamping for highest tangential rigidity without loading the drive components
- Tried and tested over decades, renowned for best possible operational safety



FIBROMAX®

**Heavy-duty NC rotary tables with twin drive**

- Transport loads over 400 tons
- Positioning as well as circular and simultaneous multi-axis machining
- Available in the modular system as a stand-alone rotary table and as a rotary-linear table
- With additional tilting axis, perfectly suitable for machining wind turbine hubs

**Your benefits**

- Roller bearing for highest cost-effectiveness and minimal energy consumption with lowest temperature rise
- Twin drive for highest precision and low backlash
- Design with force distribution optimisation for highest rigidity
- Pre-stressed, largely dimensioned axial/radial bearing for highest resistance to tilt and best axial runout accuracy and concentricity
- Highest geometric accuracy in the  $\mu$  range
- High-resolution encoder for excellent positioning accuracy (up to  $\pm 2''$ ) and repeat accuracy (up to  $\pm 0.25''$ )
- Hydraulic table top clamping for highest tangential rigidity without loading the drive components

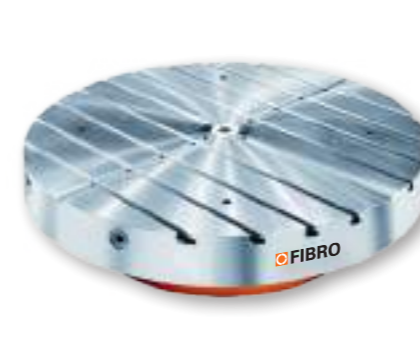

FIBRODYN® DA

**Highly dynamic NC rotary tables with direct torque drive**

- Highest speeds and accelerations
- Diverse operating modes without spanning: positioning mode, rotary, circular and simultaneous machining
- Suitable for applications not permitting any backlash
- Highest machining accuracies at extremely low speeds

**Your benefits**

- Highest dynamics for extremely fast positioning times
- High-precision bearings for perfect concentric and axial runout
- Integrated motor to prevent interference contours
- Without gear parts to minimise damage in the event of collisions
- High-resolution encoder for excellent positioning accuracy (up to  $\pm 2''$ ) and repeat accuracy (up to  $\pm 0.2''$ )
- Hydraulic table top clamping for highest tangential rigidity
- Compatible with the FIBROPLAN® model as an upgrade option for fastest acceleration without additional design overhead



FIBROTAKT®

**Precision rotary tables with Hirth face gear**

- For precision positioning applications up to  $\pm 1''$ , repeat accuracy up to  $\pm 0.1''$
- No NC controller required
- Driven and controlled hydraulically, electrically or pneumatically
- Also available as a built-in variant for integrated machine designs, e.g. custom rotary indexing table machines

**Your benefits**

- Precision FIBRO face gear for best geometric accuracies
- Hydraulic locking of the face gear for highest resistance to tilt
- Flat design for maximum operating area
- Sturdy, wear-resistant design for long service life with low maintenance overhead
- Extremely broad spectrum of sizes, fittable with table top diameters up to 3,000 mm
- Transport loads up to 15 tons
- Tried and tested over decades: the pioneer amongst rotary tables for reliable process deployment in your production process



CUSTOM SOLUTIONS

**Customer-specific rotary tables**

- Rotary-table solutions tailored to your applications, e.g.:
  - Rotary table multi-axis combinations
  - Planetary tables
  - Built-in rotary tables
  - Rotary-linear tables
  - Stand-alone rotary tables

**Your benefits**

- Lowest tooling times with the most flexible positioning and machining capabilities
- The best of all our rotary tables combined into one solution
- From problem-solving to delivery – everything from a single source
- Many years of FIBRO expertise in the engineering and design of custom rotary-table solutions for highest flexibility and process reliability
- Highest level of production expertise in conjunction with a comprehensive range of machinery
- Alignment with interfaces and machine concepts required by the customer

**THE CNC EXPERT  
FIBROPLAN®**



FIBROPLAN® NC rotary tables are characterised by CNC controlled circular milling and positioning movement. They are used in a variety of machine types, controlled either by a drive unit within the machine tool or a separate CNC controller. The modern design with a rigid mechanical structure, combined with high-quality drive and control elements, offers great advantages.

THE FIBROPLAN® MANUFACTURING PROGRAMME OFFERS A WIDE RANGE OF TYPES, SIZES AND PERFORMANCE SPECIFICATIONS AND ALLOWS FOR SELECTING THE IDEAL PRODUCT FOR EACH INDIVIDUAL APPLICATION. THE FOLLOWING STYLES ARE AVAILABLE:



STANDARD STYLE

The standard style has been designed mainly for horizontal use (in relation to the surface of the table top). The structural design is compact and the height is kept very low. This ensures maximum utilisation of the machine tool's working space and highest rigidity. In the case of sizes 2 through 4, vertical use is possible due to a second mounting surface.

VERTICAL STYLE

The vertical style has been designed mainly for vertical use (in relation to the surface of the table top). The structural design is compact with a relatively low centre height. Vertical rotary tables are coordinated with the counter bearings in regard to height. Horizontal use is also possible.



MULTI-AXIS STYLE

Multiple axis designs, e.g. for 5-axis machining and machining tasks with complicated angles. Designs with a pallet-clamping device for accommodating pallets and machine-integrated designs. For all applications, we offer qualified consulting with all our expertise as a rotary-table expert.

# OUR TECHNICAL HIGHLIGHTS YOUR COMPETITIVE EDGE

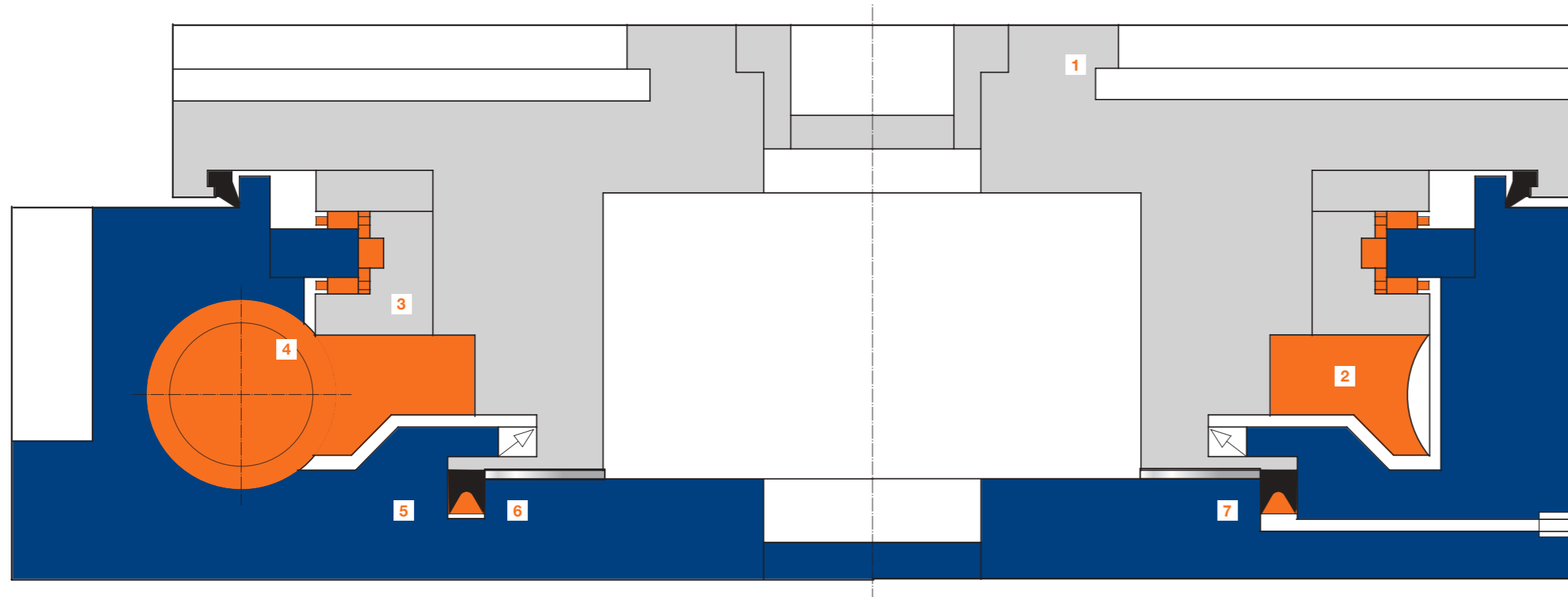

- 1 Table top
- 2 Worm gear attached to table top
- 3 Bearing
- 4 Worm with adjustable backlash
- 5 Housing
- 6 Ring piston for hydraulic clamping
- 7 Flexible disc for hydraulic clamping

THE FIBROPLAN® NC ROTARY TABLE CONSISTS OF A BASE UNIT WITH THE MAIN MECHANICAL COMPONENTS: HOUSING, TABLE TOP, BEARING AND GEARBOX, ADDITIONAL ASSEMBLIES, HYDRAULIC CLAMPING, MEASURING SYSTEM AND DRIVE MOTOR. OPTIONAL ACCESSORIES SUCH AS THE NC CONTROL AND OTHER COMPREHENSIVE ACCESSORIES ALLOW FOR THE EXPANSION TO A COMPLETE, NC-CONTROLLED ROTARY AND POSITIONING AXIS.

## TECHNICAL HIGHLIGHTS

- Flexible positioning in freely selectable angular steps
- Positioning accuracy with corresponding selection and arrangement of the measuring system up to  $\pm 10''$  (indirect) or  $\pm 2.5''$  (direct)
- High precision in terms of radial and facial runout due to selected, preloaded radial/axial combination bearings of the largest possible diameter
- Accommodation of high machining forces and torques
- Hydraulic table clamp for increasing static strength with a simultaneous relief of the gearing system
- Reliable with regard to simultaneous machining due to preloaded bearings and adjustable worm gearing to achieve near-zero backlash
- High operating safety and long operating life thanks to careful structural design
- Low maintenance due to life-time lubrication
- Wide variety of batch-produced standard models with many variants selectable from a modular supplementary system
- Multiple-axis designs and combinations with slide tables
- Designs with a pallet-clamping device and pallets
- Specific solutions for special applications

# CONSTRUCTION TYPE HORIZONTAL USE POSITION

# CONSTRUCTION TYPE VERTICAL USE POSITION

NC. 1.02	NC. 1.03	NC. 1.04	NC. 1.05	NC. 1.06	NC. 1.07	NC. 1.08	NC. 1.09	NC. 1.10	NC. 2.01
Page 12	Page 14	Page 16	Page 18	Page 20	Page 22	Page 24	Page 26	Page 28	Page 30

## Main dimensions

Table top Ø	mm	240/280	340/400	420/500	520/630	630/800	800/1,000	1,000/1,250	1,250/1,500	1,600	180
Overall height	mm	190	190	210	205	225	250	290	350	370	130
Bearing Ø	mm	120×210	200×300	260×385	325×450	395×525	460×600	650×870	850×1,095	1,030×1,300	80×150

## Load data

Perm. axial loading on table top	N	31,000	40,000	58,000	99,000	115,000	135,000	309,000	389,000	822,000	5,000
Perm. transport load	kg	1,600	2,000	2,900	5,000	5,900	6,900	15,000	19,000	40,000	700
Perm. tilting moment	Nm	3,200	6,700	10,000	33,000	45,000	60,000	230,000	400,000	600,000	2,000
Perm. torque during rotary milling transmitted by worm gear unit	Nm	850	1,900	3,500	4,200	7,000	7,000	14,000	17,000	24,000	300
Perm. tangential moment with hydraulic clamping	Nm	1,200	2,000	4,000	6,000	8,000	14,000	25,000	32,000	40,000	700

## Accuracies

Indexing accuracy with indirect measurement in arc seconds, max.		± 15	± 10	± 10	± 10	± 10	± 8	± 8	± 8	± 8	± 20
With direct measurement in arc seconds dependent on measuring system, max.		± 2.5	± 2.5	± 2.5	± 2.5	± 2.5	± 2.5	± 2.5	± 2.5	± 2.5	± 2.5
Axial runout of the centre bore measured at the table top (TIR)	mm	0.01	0.01	0.01	0.01	0.01	0.01	0.01	0.01	0.01	0.01
Axial runout of the table top	mm	0.01	0.01	0.01	0.012	0.015	0.015	0.02	0.02	0.025	0.01

## Drive data

Ratio	i tot	72	120	120	240	288	360	480	360	450	72
Ratio worm gear unit		72:1	120:1	120:1	120:1	144:1	180:1	240:1	270:6	270:6	72:1
Speed of table top	rpm	41	25	22	12.5	10	8	6	8	6.5	41

NC. 2.01	NC. 1.02	NC. 1.03	NC. 1.04	NC. 2.05	NC. 2.06	NC. 2.07	NC. 2.08	NC. 2.09	NC. 2.10
Page 30	Page 12	Page 14	Page 16	Page 32	Page 34	Page 36	Page 38	Page 40	Page 42

## Main dimensions

Table top Ø	mm	180	240/280	340/400	420/500	520/630	630/800	800/1,000	1,000/1,250	1,250/1,500	1,600
Centre height	mm	130	180	245	280	360	360/440	440/550	550/670	670/800	900
Bearing Ø	mm	80×150	120×210	200×300	260×385	325×450	460×600	580×750	650×870	850×1,095	1,030×1,300

## Load data

Perm. axial loading on table top	N	5,000	9,000	10,000	11,000	45,000	75,000	100,000	120,000	160,000	200,000
Perm. transport load	kg	150	250	300	400	1,200	2,000	3,000	6,000	8,000	12,000
Perm. tilting moment	Nm	1,500	800	1,680	2,500	16,000	26,000	32,500	57,500	100,000	150,000
Perm. torque during rotary milling transmitted by worm gear unit	Nm	300	850	1,900	3,500	4,200	7,000	7,900	14,000	17,000	24,000
Perm. tangential moment with hydraulic clamping	Nm	700	1,200	2,000	4,000	6,000	8,000	14,000	25,000	32,000	40,000

## Accuracies

Indexing accuracy with indirect measurement in arc seconds, max.		± 20	± 15	± 10	± 10	± 10	± 10	± 8	± 8	± 8	± 8
With direct measurement in arc seconds dependent on measuring system, max.		± 2.5	± 2.5	± 2.5	± 2.5	± 2.5	± 2.5	± 2.5	± 2.5	± 2.5	± 2.5
Axial runout of the centre bore measured at the table top (TIR)	mm	0.01	0.01	0.01	0.01	0.01	0.01	0.01	0.01	0.01	0.01
Axial runout of the table top	mm	0.01	0.01	0.01	0.01	0.012	0.015	0.015	0.02	0.02	0.025

## Drive data

Ratio	i tot	72	72	120	120	240	288	360	480	360	450
Ratio worm gear unit		72:1	72:1	120:1	120:1	120:1	144:1	180:1	240:1	270:6	270:6
Speed of table top	rpm	41	41	25	22	12.5	10	8	6	8	6.5

# FIBROPLAN® NC. 1.02

## DIMENSIONS

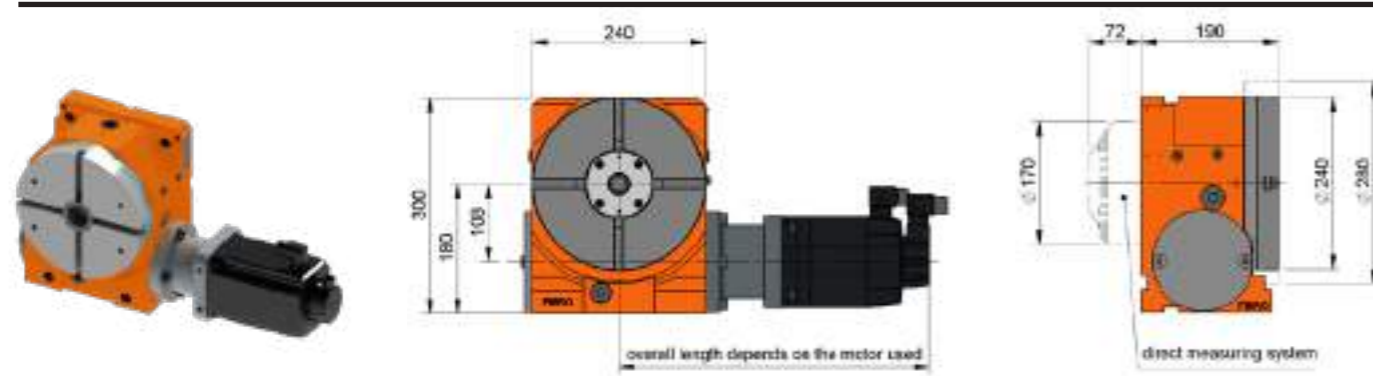

1 2 3 4 5  
 NC. 1.02 . 0 2 4 0 . 2 . 1 . 1 4 . 1 R D

CAD files, technical data and planning documents can be downloaded at [www.fibro.de](http://www.fibro.de)

ENCODING 1 2 3 4 5  
 NC. 1.02 . . . . .

### Installation position of standard horizontal/vertical table tops (specify other mounting positions on ordering)

#### 1 Table top dimensions

Standard dimensions Ø 240/280

#### 2 Table top design

Rotary	1
Rotary, with T-slots 14H7/H12	2
Square	3
Square, with T-slots 14H7/H12	4
Special version	0

#### 3 Table top clamping

Without hydraulic clamping	0	
With hydraulic clamping	1	
Nominal pressure	bar	64
Volume	cm <sup>3</sup>	4
Max. pump capacity	l/min	2

#### 4 Measuring system

Preparation for installation of measuring system	0
Delivery with installed measuring system	1
Measuring system at motor provided	2
Direct measuring system	1
Indirect measurement on the motor	4

#### 5 Motor arrangement

Preparation for installation of the motor	0
Delivery with installed motor	1
Motor provided by customer	2
Drive on left	L
Drive on right	R
Direct	D
Planetary gear	P
Belt train	R
Angular gear box	W
Hand crank	H
Special version	S

### TECHNICAL DATA

Max. centre borehole (special version)	mm	Ø 65
Bearing: inner Ø × outer Ø	mm	120×210
Weight with Ø 240 mm table top (without motor)	kg	80

Special versions available on request

### ACCURACIES

#### Direct measuring system

System accuracy in arc seconds	max.	± 1
Indexing accuracy in arc seconds	max.	± 2.5
Indexing accuracy in arc length on Ø 240 mm	max.	± 0.0015

#### Indirect measuring system

Indexing accuracy in arc seconds	max.	± 15
Indexing accuracy in arc length on Ø 240 mm	max.	± 0.009

#### Geometric accuracies

Runout: centre bore	mm	0.01
Axial runout precision on Ø 240 mm	mm	0.01
Plane parallelism of housing/table top related to Ø 240 mm	mm	0.02

Higher geometric accuracies available on request

### LOAD DATA

1	Perm. axial loading on table top, horizontal	N	31,000
2	Perm. axial loading on table top, vertical	N	9,000
3	Perm. radial loading on table top	N	35,000
4	Perm. transport load on table top, horizontal	kg	1,600
	Perm. transport load on table top, vertical (flying load)	kg	250
5	Perm. support load on table top, vertical (with counter bearing)	kg	1,600
6	Permissible tilting moment, horizontal on positioned table top on rotating table top	Nm	3,200 800
7	Permissible tilting moment, vertical on positioned table top on rotating table top	Nm	2,000 500
8	Perm. tangential moment on positioned table top with hydraulic clamping	Nm	1,200
9	Perm. torque limit transferable by standard worm	Nm	850

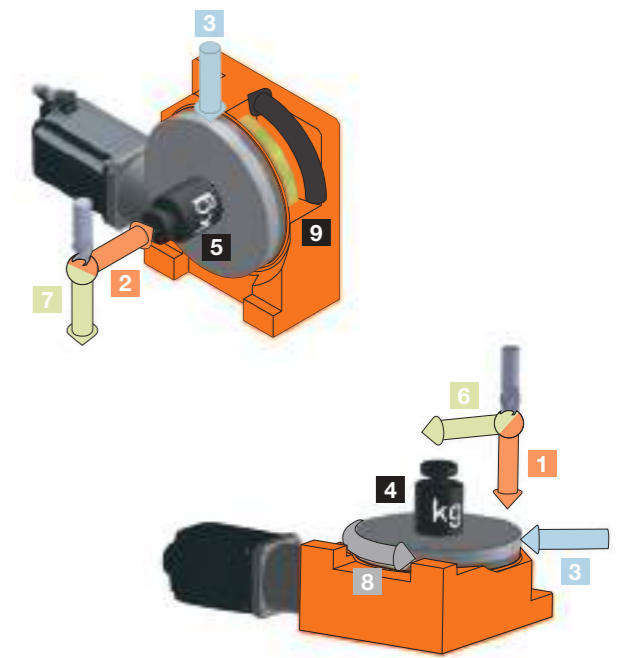

### SAMPLE DESIGN NC. 1.02

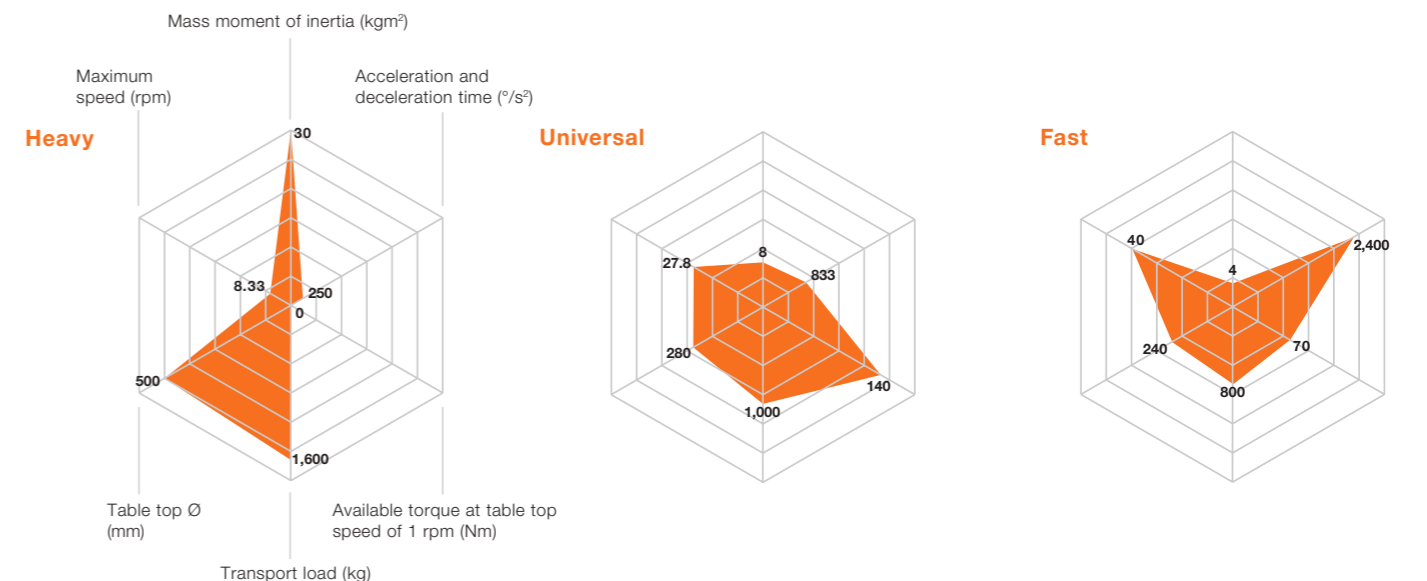

# FIBROPLAN® NC. 1.03

## DIMENSIONS

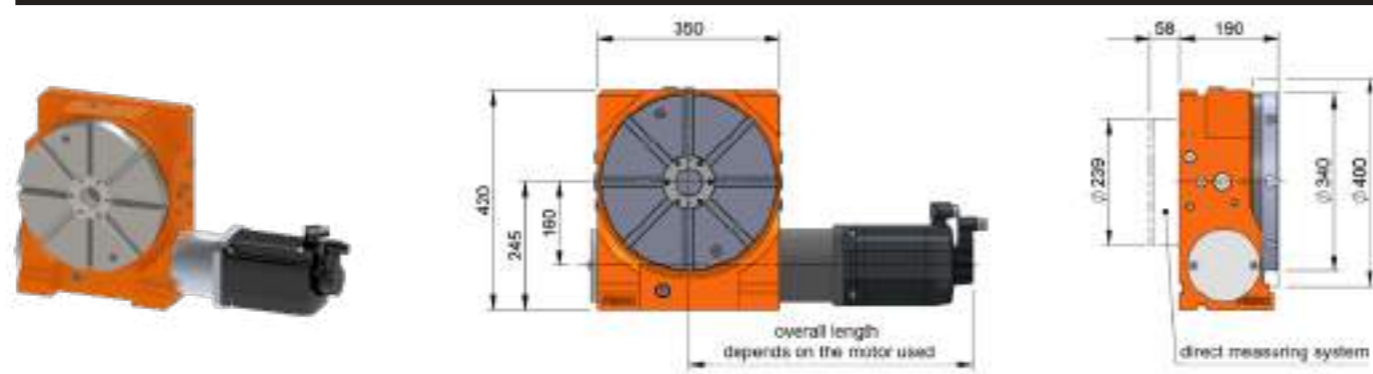

CAD files, technical data and planning documents can be downloaded at [www.fibro.de](http://www.fibro.de)



**Installation position of standard horizontal/vertical table tops** (specify other mounting positions on ordering)

### 1 Table top dimensions

Standard dimensions Ø	340/400
-----------------------	---------

### 2 Table top design

Rotary	1
Rotary, with T-slots 14H7/H12	2
Square	3
Square, with T-slots 14H7/H12	4
Special version	0

### 3 Table top clamping

Without hydraulic clamping	0	
With hydraulic clamping	1	
Nominal pressure	bar	64
Volume	cm <sup>3</sup>	4
Max. pump capacity	l/min	2

### 4 Measuring system

Preparation for installation of measuring system	0
Delivery with installed measuring system	1
Measuring system at motor provided	2
Direct measuring system	1
Indirect measurement on the motor	4

### 5 Motor arrangement

Preparation for installation of the motor	0
Delivery with installed motor	1
Motor provided by customer	2
Drive on left	L
Drive on right	R
Direct	D
Planetary gear	P
Belt train	R
Angular gear box	W
Hand crank	H
Special version	S

## TECHNICAL DATA

Max. centre borehole (special version)	mm	Ø 110
Bearing: inner Ø × outer Ø	mm	200×300
Weight with Ø 340 mm table top (without motor)	kg	170

Special versions available on request

## ACCURACIES

### Direct measuring system

System accuracy in arc seconds	max.	± 1
Indexing accuracy in arc seconds	max.	± 2.5
Indexing accuracy in arc length on Ø 340 mm	max.	± 0.002

### Indirect measuring system

Indexing accuracy in arc seconds	max.	± 10
Indexing accuracy in arc length on Ø 340 mm	max.	± 0.008

### Geometric accuracies

Runout: centre bore	mm	0.01
Axial runout precision on Ø 340 mm	mm	0.01
Plane parallelism of housing/table top related to Ø 340 mm	mm	0.02

Higher geometric accuracies available on request

## LOAD DATA

1	Perm. axial loading on table top, horizontal	N	40,000
2	Perm. axial loading on table top, vertical	N	10,000
3	Perm. radial loading on table top	N	44,000
4	Perm. transport load on table top, horizontal	kg	2,000
	Perm. transport load on table top, vertical (flying load)	kg	300
5	Perm. support load on table top, vertical (with counter bearing)	kg	2,000
6	Permissible tilting moment, horizontal on positioned table top	Nm	6,700
	on rotating table top	Nm	1,675
7	Permissible tilting moment, vertical on positioned table top	Nm	4,000
	on rotating table top	Nm	1,000
8	Perm. tangential moment on positioned table top with hydraulic clamping	Nm	2,000
9	Perm. torque limit transferable by standard worm	Nm	1,900

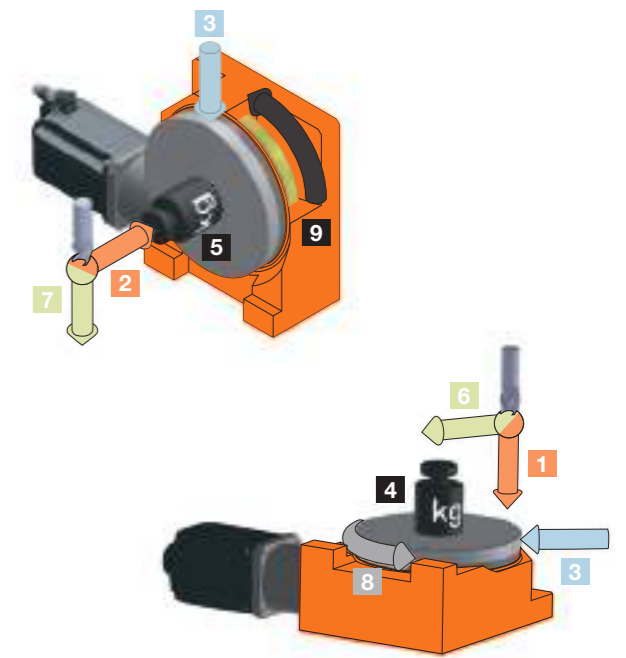

## SAMPLE DESIGN NC. 1.03

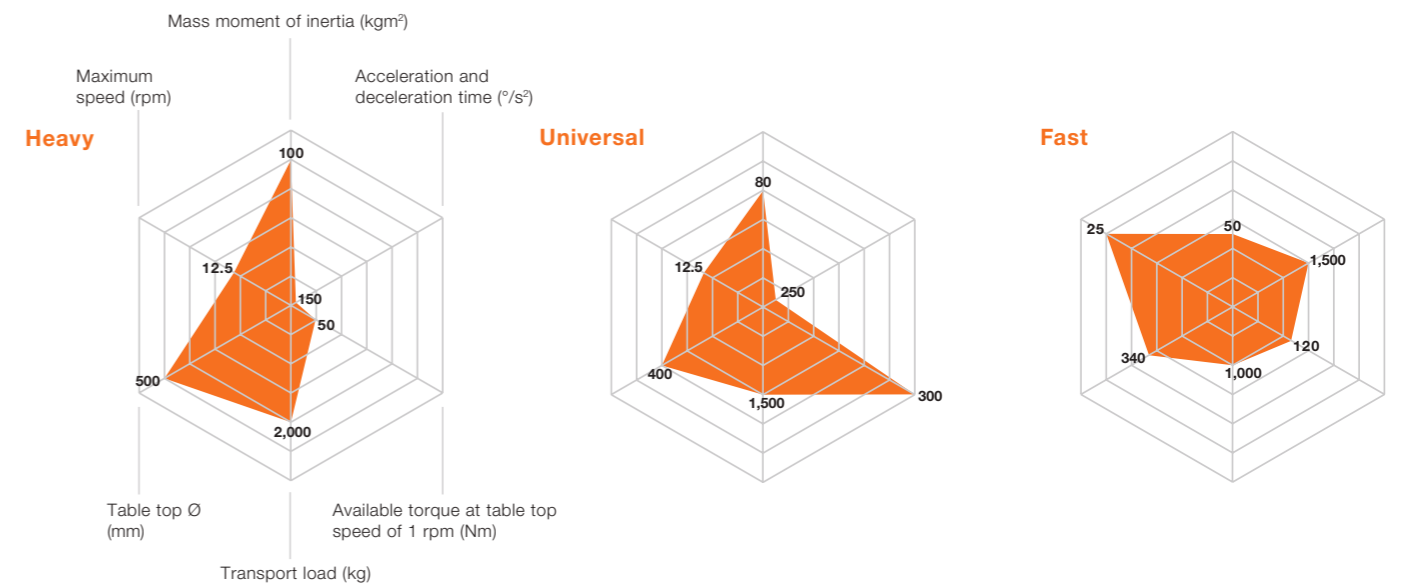



# FIBROPLAN® NC. 1.04

## DIMENSIONS

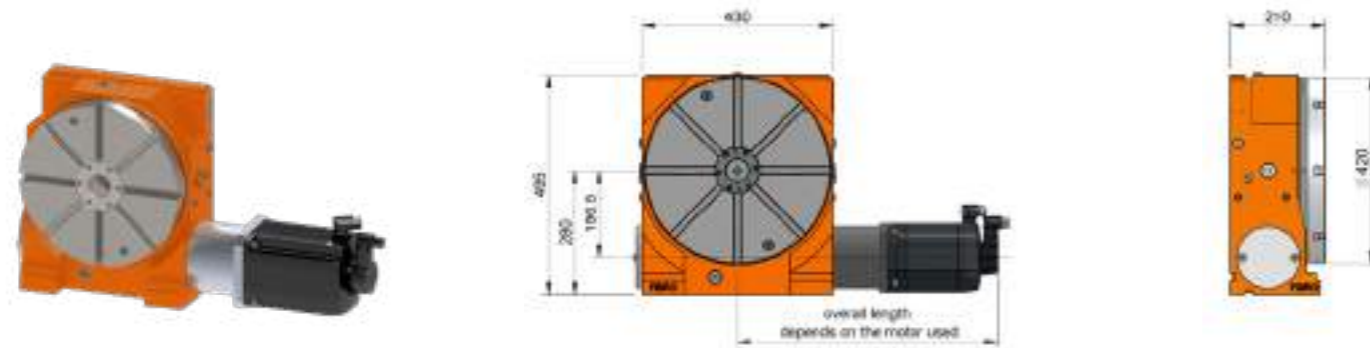

1 2 3 4 5  
 NC. 1.04 . 0 4 2 0 . 2 . 1 . 1 4 . 1 R D

CAD files, technical data and planning documents can be downloaded at [www.fibro.de](http://www.fibro.de)

ENCODING 1 2 3 4 5  
 NC. 1.04 . . . . .

### Installation position of standard horizontal/vertical table tops (specify other mounting positions on ordering)

#### 1 Table top dimensions

Standard dimensions Ø 420/500

#### 2 Table top design

Rotary	1
Rotary, with T-slots 14H7/H12	2
Square	3
Square, with T-slots 14H7/H12	4
Special version	0

#### 3 Table top clamping

Without hydraulic clamping	0	
With hydraulic clamping	1	
Nominal pressure	bar	64
Volume	cm <sup>3</sup>	4
Max. pump capacity	l/min	3

#### 4 Measuring system

Preparation for installation of measuring system	0
Delivery with installed measuring system	1
Measuring system at motor provided	2
Direct measuring system	1
Indirect measurement on the motor	4

#### 5 Motor arrangement

Preparation for installation of the motor	0
Delivery with installed motor	1
Motor provided by customer	2
Drive on left	L
Drive on right	R
Direct	D
Planetary gear	P
Belt train	R
Angular gear box	W
Hand crank	H
Special version	S

## TECHNICAL DATA

Max. centre borehole (special version)	mm	Ø 140
Bearing: inner Ø × outer Ø	mm	260×385
Weight with Ø 420 mm table top (without motor)	kg	270

Special versions available on request

## ACCURACIES

### Direct measuring system

System accuracy in arc seconds	max.	± 1
Indexing accuracy in arc seconds	max.	± 2.5
Indexing accuracy in arc length on Ø 420 mm	max.	±0.003

### Indirect measuring system

Indexing accuracy in arc seconds	max.	± 10
Indexing accuracy in arc length on Ø 420 mm	max.	±0.01

### Geometric accuracies

Runout: centre bore	mm	0.01
Axial runout precision on Ø 420 mm	mm	0.01
Plane parallelism of housing/table top related to Ø 420 mm	mm	0.02

Higher geometric accuracies available on request

## LOAD DATA

1	Perm. axial loading on table top, horizontal	N	58,000
2	Perm. axial loading on table top, vertical	N	11,000
3	Perm. radial loading on table top	N	51,000
4	Perm. transport load on table top, horizontal	kg	2,900
	Perm. transport load on table top, vertical (flying load)	kg	400
5	Perm. support load on table top, vertical (with counter bearing)	kg	2,900
6	Permissible tilting moment, horizontal on positioned table top on rotating table top	Nm	10,000 Nm 2,500
7	Permissible tilting moment, vertical on positioned table top on rotating table top	Nm	6,000 Nm 1,500
8	Perm. tangential moment on positioned table top with hydraulic clamping	Nm	4,000
9	Perm. torque limit transferable by standard worm	Nm	3,500

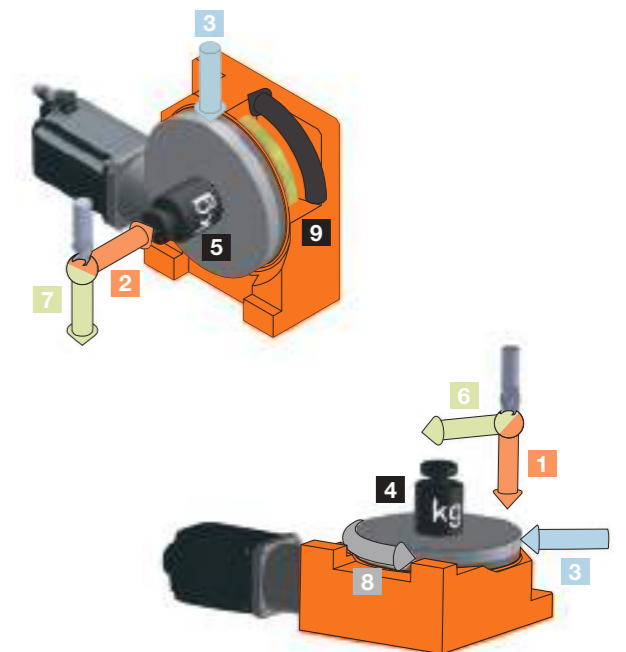

## SAMPLE DESIGN NC. 1.04

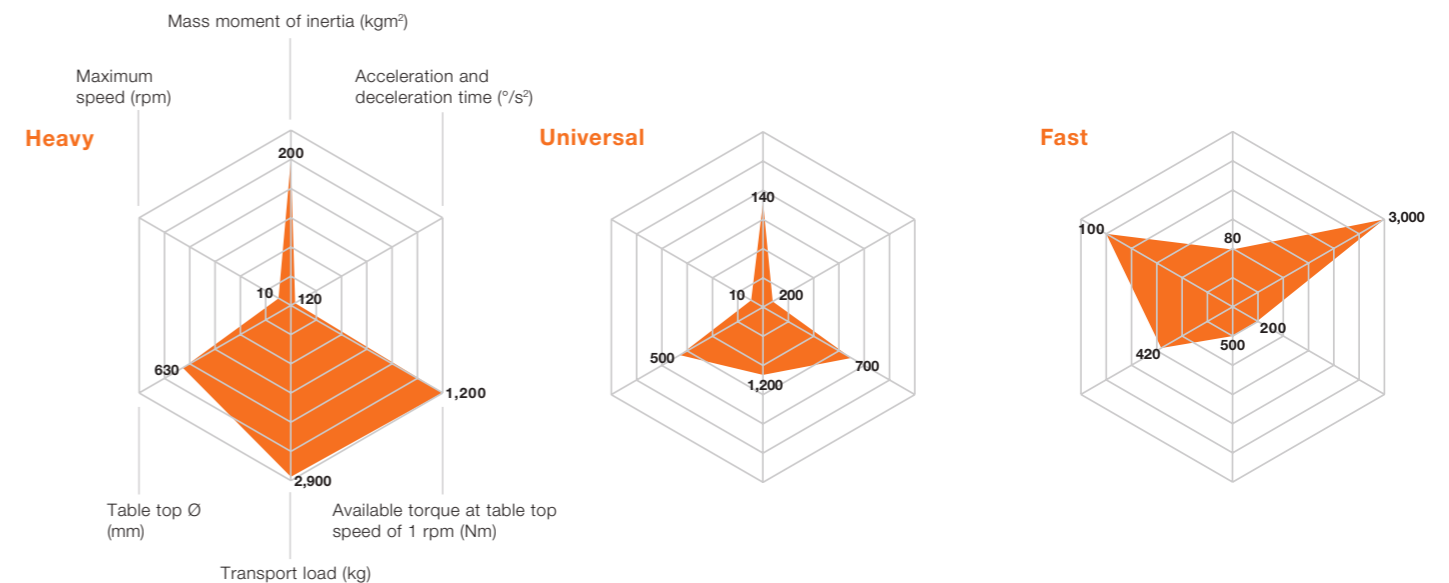

# FIBROPLAN® NC. 1.05

## DIMENSIONS



1 2 3 4 5  
 NC. 1.05 . 0 5 2 0 . 2 . 1 . 1 4 . 1 R Z

CAD files, technical data and planning documents can be downloaded at [www.fibro.de](http://www.fibro.de)

ENCODING 1 2 3 4 5  
 NC. 1.05 . . . . .

Installation position of standard horizontal table tops (specify other mounting positions on ordering)

### 1 Table top dimensions

Standard dimensions Ø 520/630

### 2 Table top design

Rotary	1
Rotary, with T-slots 14H7/H12	2
Square	3
Square, with T-slots 14H7/H12	4
Special version	0

### 3 Table top clamping

Without hydraulic clamping	0	
With hydraulic clamping	1	
Nominal pressure	bar	64
Volume	cm <sup>3</sup>	4
Max. pump capacity	l/min	4

### 4 Measuring system

Preparation for installation of measuring system	0
Delivery with installed measuring system	1
Measuring system at motor provided	2
Direct measuring system	1
Indirect measurement on the motor	4

### 5 Motor arrangement

Preparation for installation of the motor	0
Delivery with installed motor	1
Motor provided by customer	2
Drive on left	L
Drive on right	R
Gear wheel train	Z
Direct	D
Planetary gear	P
Belt train	R
Angular gear box	W
Hand crank	H
Special version	S

## TECHNICAL DATA

Max. centre borehole (special version)	mm	Ø 140
Bearing: inner Ø × outer Ø	mm	325×450
Weight with Ø 520 mm table top (without motor)	kg	360

Special versions available on request

## ACCURACIES

### Direct measuring system

System accuracy in arc seconds	max.	± 1
Indexing accuracy in arc seconds	max.	± 2.5
Indexing accuracy in arc length on Ø 520 mm	max.	± 0.003

### Indirect measuring system

Indexing accuracy in arc seconds	max.	± 10
Indexing accuracy in arc length on Ø 520 mm	max.	± 0.013

### Geometric accuracies

Runout: centre bore	mm	0.01
Axial runout precision on Ø 520 mm	mm	0.012
Plane parallelism of housing/table top related to Ø 520 mm	mm	0.025

Higher geometric accuracies available on request

## LOAD DATA

1	Perm. axial loading on table top, horizontal	N	99,000
3	Perm. radial loading on table top	N	67,000
4	Perm. transport load on table top, horizontal	kg	5,000
6	Permissible tilting moment, horizontal on positioned table top on rotating table top	Nm	33,000 8,250
8	Perm. tangential moment on positioned table top with hydraulic clamping	Nm	6,000
9	Perm. torque limit transferable by standard worm	Nm	4,200

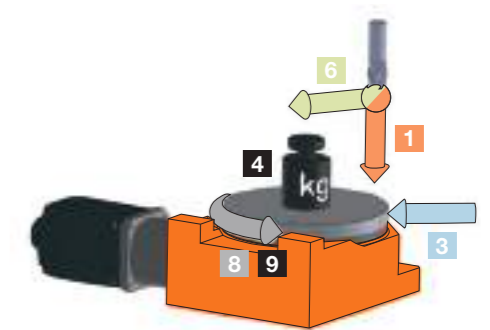

## SAMPLE DESIGN NC. 1.05

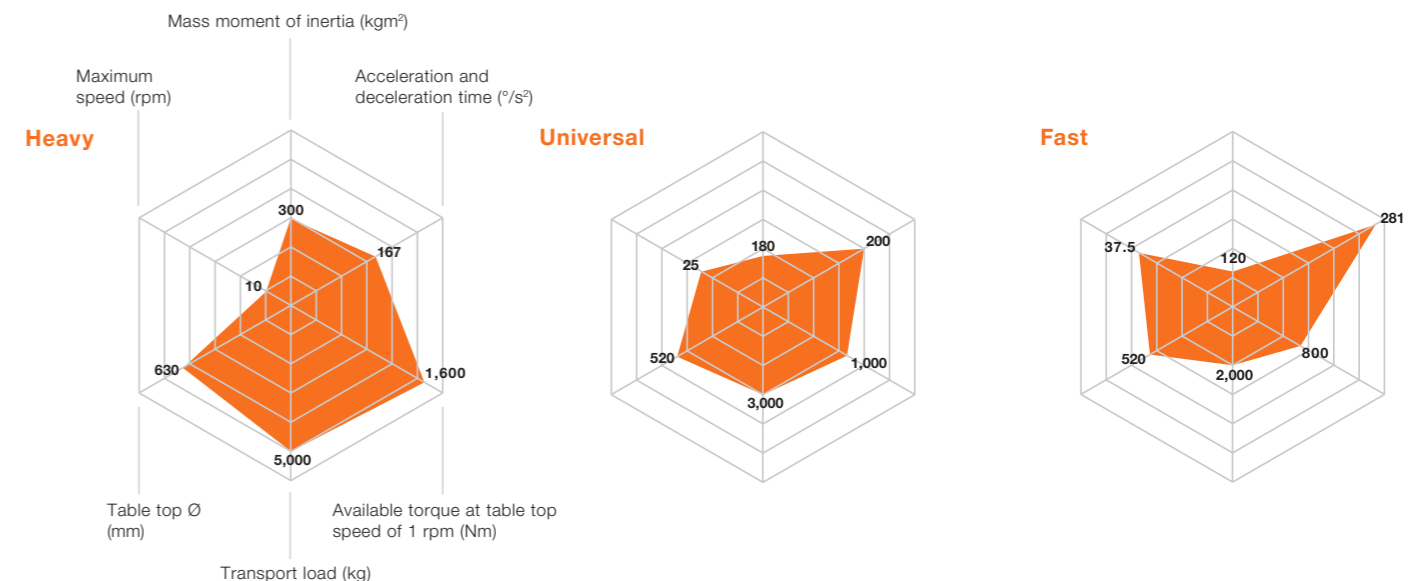

# FIBROPLAN® NC. 1.06

## DIMENSIONS



	<b>1</b>	<b>2</b>	<b>3</b>	<b>4</b>	<b>5</b>
NC. 1.06	0	6	3	0	2
	1	1	4	1	R Z

CAD files, technical data and planning documents can be downloaded at [www.fibro.de](http://www.fibro.de)

	<b>1</b>	<b>2</b>	<b>3</b>	<b>4</b>	<b>5</b>
ENCODING	NC. 1.06				

**Installation position of standard horizontal table tops** (specify other mounting positions on ordering)

### 1 Table top dimensions

Standard dimensions Ø	630/800
-----------------------	---------

### 2 Table top design

Rotary	1
Rotary, with T-slots 18H7/H12	2
Square	3
Square, with T-slots 18H7/H12	4
Special version	0

### 3 Table top clamping

Without hydraulic clamping	0	
With hydraulic clamping	1	
Nominal pressure	bar	64
Volume	cm <sup>3</sup>	4
Max. pump capacity	l/min	5

### 4 Measuring system

Preparation for installation of measuring system	0
Delivery with installed measuring system	1
Measuring system at motor provided	2
Direct measuring system	1
Indirect measurement on the motor	4

### 5 Motor arrangement

Preparation for installation of the motor	0
Delivery with installed motor	1
Motor provided by customer	2
Drive on left	L
Drive on right	R
Gear wheel train	Z
Direct	D
Planetary gear	P
Belt train	R
Angular gear box	W
Hand crank	H
Special version	S

## TECHNICAL DATA

Max. centre borehole (special version)	mm	Ø 190
Bearing: inner Ø × outer Ø	mm	395×525
Weight with Ø 630 mm table top (without motor)	kg	550

Special versions available on request

## ACCURACIES

### Direct measuring system

System accuracy in arc seconds	max.	± 1
Indexing accuracy in arc seconds	max.	± 2.5
Indexing accuracy in arc length on Ø 630 mm	max.	± 0.004

### Indirect measuring system

Indexing accuracy in arc seconds	max.	± 10
Indexing accuracy in arc length on Ø 630 mm	max.	± 0.015

### Geometric accuracies

Runout: centre bore	mm	0.01
Axial runout precision on Ø 630 mm	mm	0.015
Plane parallelism of housing/table top related to Ø 630 mm	mm	0.03

Higher geometric accuracies available on request

## LOAD DATA

<b>1</b>	Perm. axial loading on table top, horizontal	N	115,000
<b>3</b>	Perm. radial loading on table top	N	67,000
<b>4</b>	Perm. transport load on table top, horizontal	kg	5,900
<b>6</b>	Permissible tilting moment, horizontal on positioned table top on rotating table top	Nm	45,000 Nm 11,250
<b>8</b>	Perm. tangential moment on positioned table top with hydraulic clamping	Nm	8,000
<b>9</b>	Perm. torque limit transferable by standard worm	Nm	7,000

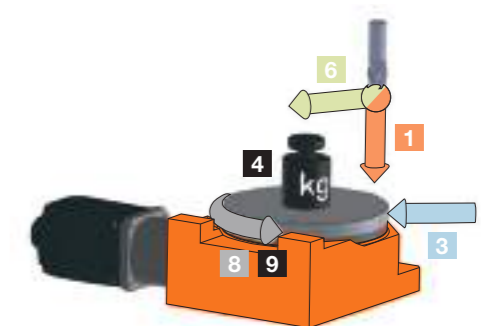

## SAMPLE DESIGN NC. 1.06

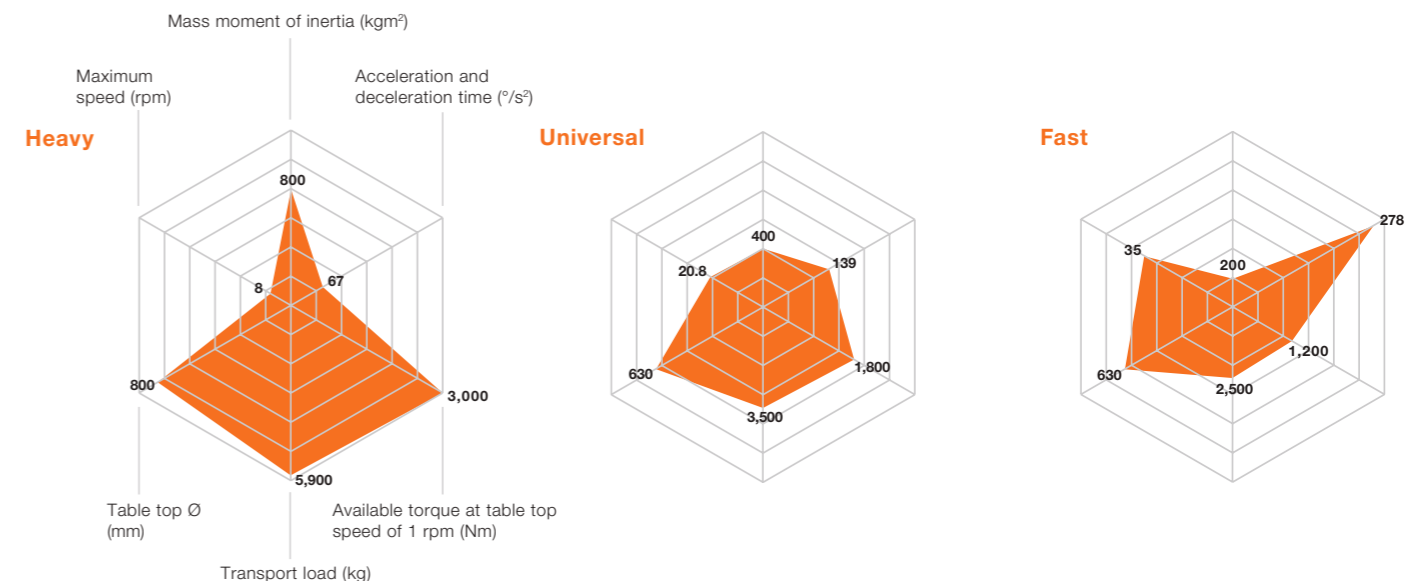

# FIBROPLAN® NC. 1.07

## DIMENSIONS

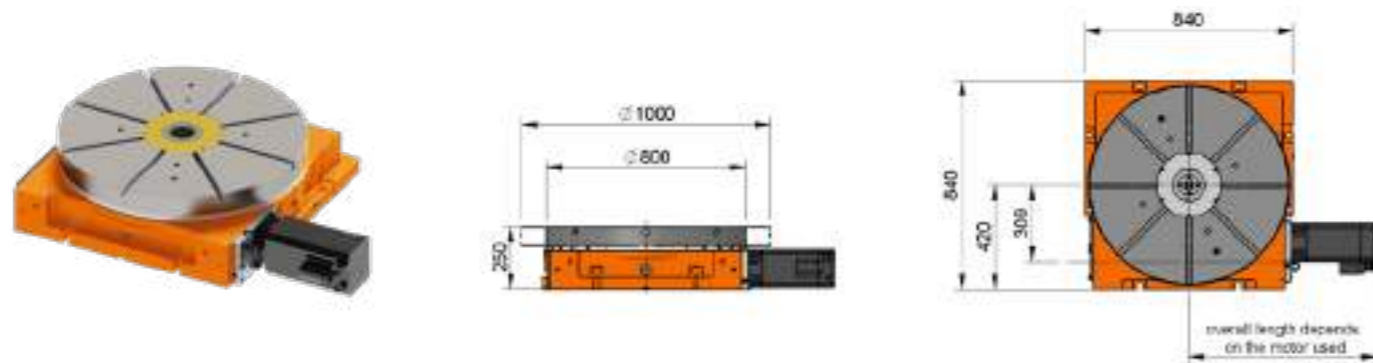

1 2 3 4 5  
 NC. 1.07 . 0 8 0 0 . 2 . 1 . 1 4 . 1 R Z

CAD files, technical data and planning documents can be downloaded at [www.fibro.de](http://www.fibro.de)

ENCODING 1 2 3 4 5  
 NC. 1.07 . . . . .

Installation position of standard horizontal table tops (specify other mounting positions on ordering)

### 1 Table top dimensions

Standard dimensions Ø 800/1,000

### 2 Table top design

Rotary	1
Rotary, with T-slots 18H7/H12	2
Square	3
Square, with T-slots 18H7/H12	4
Special version	0

### 3 Table top clamping

Without hydraulic clamping	0	
With hydraulic clamping	1	
Nominal pressure	bar	64
Volume	cm <sup>3</sup>	4
Max. pump capacity	l/min	6

### 4 Measuring system

Preparation for installation of measuring system	0
Delivery with installed measuring system	1
Measuring system at motor provided	2
Direct measuring system	1
Indirect measurement on the motor	4

### 5 Motor arrangement

Preparation for installation of the motor	0
Delivery with installed motor	1
Motor provided by customer	2
Drive on left	L
Drive on right	R
Gear wheel train	Z
Direct	D
Planetary gear	P
Belt train	R
Angular gear box	W
Hand crank	H
Special version	S

## TECHNICAL DATA

Max. centre borehole (special version)	mm	Ø 250
Bearing: inner Ø × outer Ø	mm	460×600
Weight with Ø 800 mm table top (without motor)	kg	920

Special versions available on request

## ACCURACIES

### Direct measuring system

System accuracy in arc seconds	max.	± 1
Indexing accuracy in arc seconds	max.	± 2.5
Indexing accuracy in arc length on Ø 800 mm	max.	± 0.005

### Indirect measuring system

Indexing accuracy in arc seconds	max.	± 8
Indexing accuracy in arc length on Ø 800 mm	max.	± 0.016

### Geometric accuracies

Runout: centre bore	mm	0.01
Axial runout precision on Ø 800 mm	mm	0.015
Plane parallelism of housing/table top related to Ø 800 mm	mm	0.03

Higher geometric accuracies available on request

## LOAD DATA

1	Perm. axial loading on table top, horizontal	N	135,000
3	Perm. radial loading on table top	N	93,000
4	Perm. transport load on table top, horizontal	kg	6,900
6	Permissible tilting moment, horizontal on positioned table top on rotating table top	Nm	60,000 Nm 15,000
8	Perm. tangential moment on positioned table top with hydraulic clamping	Nm	14,000
9	Perm. torque limit transferable by standard worm	Nm	7,000

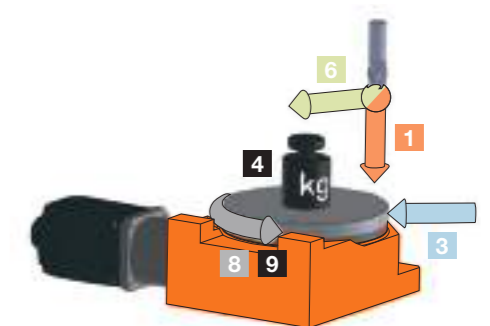

## SAMPLE DESIGN NC. 1.07

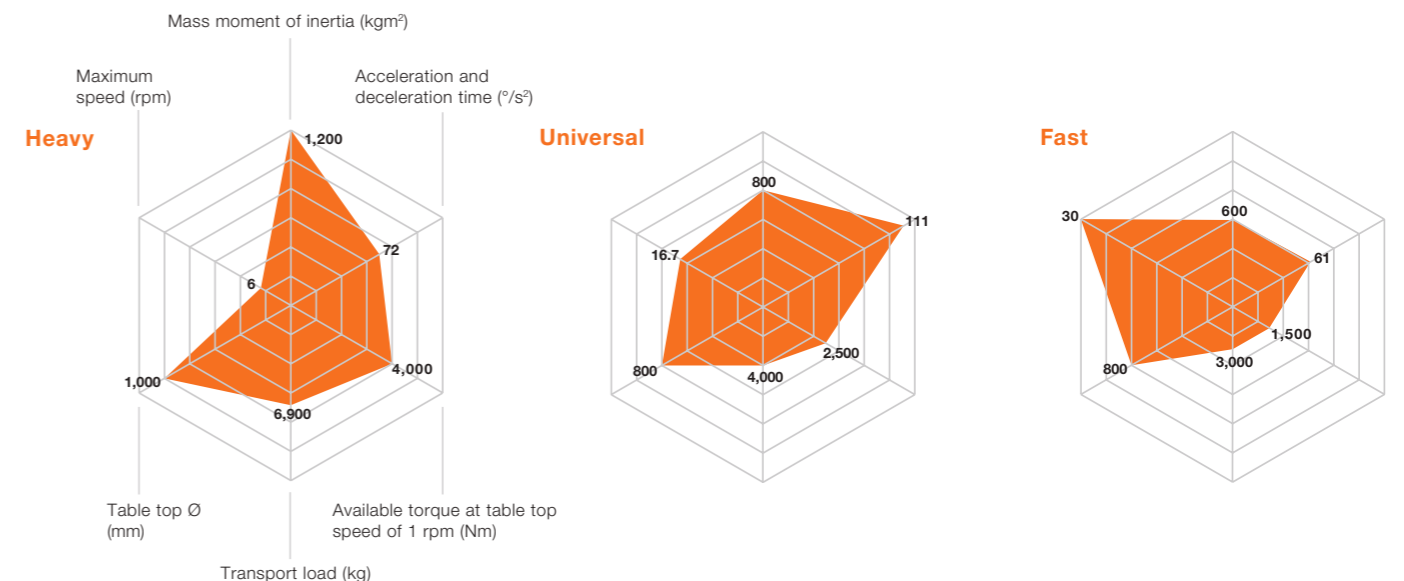

# FIBROPLAN® NC. 1.08

## DIMENSIONS



1 2 3 4 5  
 NC. 1.08 . 1 0 0 0 . 2 . 1 . 1 4 . 1 R Z

CAD files, technical data and planning documents can be downloaded at [www.fibro.de](http://www.fibro.de)

ENCODING 1 2 3 4 5  
 NC. 1.08 . . . . .

### Installation position of standard horizontal table tops (specify other mounting positions on ordering)

#### 1 Table top dimensions

Standard dimensions Ø 1,000/1,250

#### 2 Table top design

Rotary	1
Rotary, with T-slots 22H7/H12	2
Square	3
Square, with T-slots 22H7/H12	4
Special version	0

#### 3 Table top clamping

Without hydraulic clamping	0	
With hydraulic clamping	1	
Nominal pressure	bar	64
Volume	cm <sup>3</sup>	4
Max. pump capacity	l/min	8

#### 4 Measuring system

Preparation for installation of measuring system	0
Delivery with installed measuring system	1
Measuring system at motor provided	2
Direct measuring system	1
Indirect measurement on the motor	4

#### 5 Motor arrangement

Preparation for installation of the motor	0
Delivery with installed motor	1
Motor provided by customer	2
Drive on left	L
Drive on right	R
Gear wheel train	Z
Direct	D
Planetary gear	P
Belt train	R
Angular gear box	W
Hand crank	H
Special version	S

### TECHNICAL DATA

Max. centre borehole (special version)	mm	Ø 420
Bearing: inner Ø × outer Ø	mm	650×870
Weight with Ø 1,000 mm table top (without motor)	kg	1,550

Special versions available on request

### ACCURACIES

#### Direct measuring system

System accuracy in arc seconds	max.	± 1
Indexing accuracy in arc seconds	max.	± 2.5
Indexing accuracy in arc length on Ø 1,000 mm	max.	±0.006

#### Indirect measuring system

Indexing accuracy in arc seconds	max.	± 8
Indexing accuracy in arc length on Ø 1,000 mm	max.	± 0.019

#### Geometric accuracies

Runout: centre bore	mm	0.01
Axial runout precision on Ø 1,000 mm	mm	0.02
Plane parallelism of housing/table top related to Ø 1,000 mm	mm	0.04

Higher geometric accuracies available on request

### LOAD DATA

1	Perm. axial loading on table top, horizontal	N	309,000
3	Perm. radial loading on table top	N	237,000
4	Perm. transport load on table top, horizontal	kg	15,000
6	Permissible tilting moment, horizontal on positioned table top on rotating table top	Nm	230,000 Nm 57,500
8	Perm. tangential moment on positioned table top with hydraulic clamping	Nm	25,000
9	Perm. torque limit transferable by standard worm	Nm	14,000

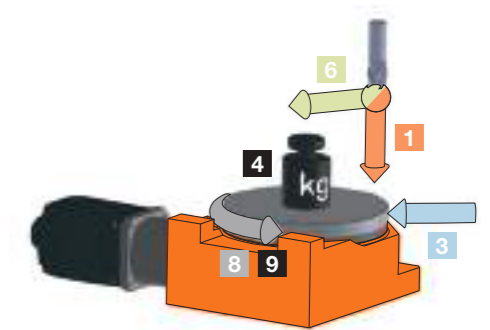

### SAMPLE DESIGN NC. 1.08

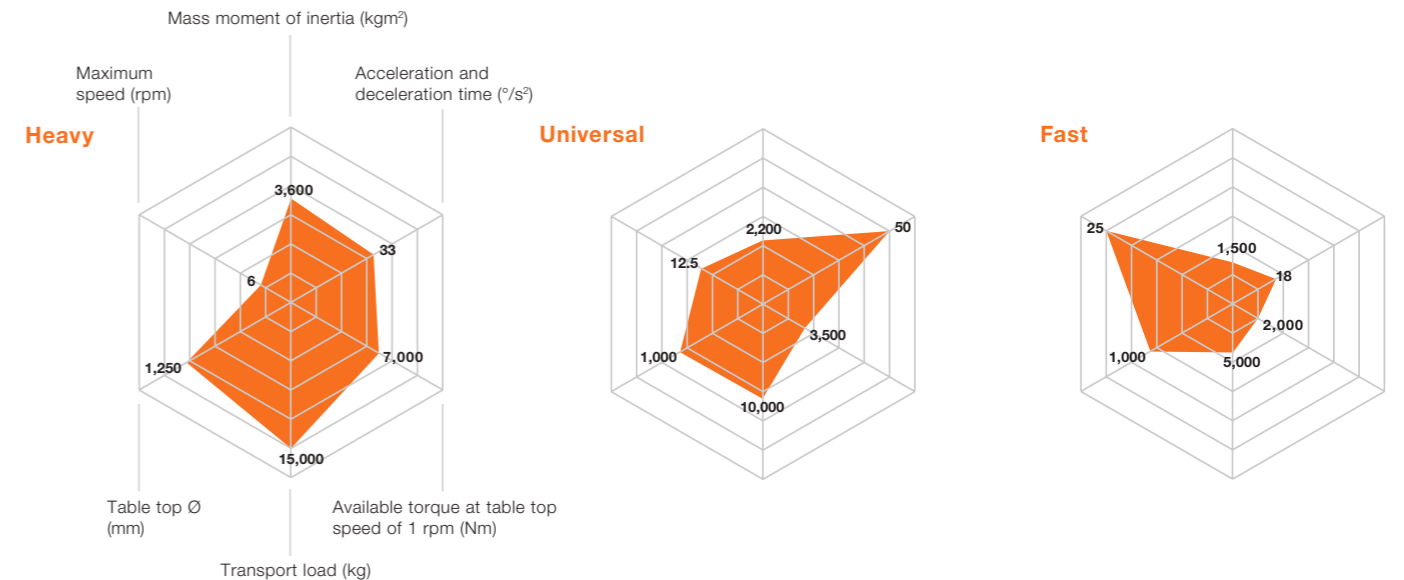

# FIBROPLAN® NC. 1.09

## DIMENSIONS

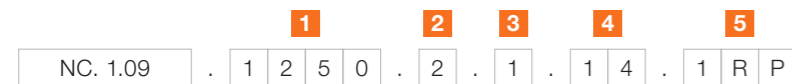
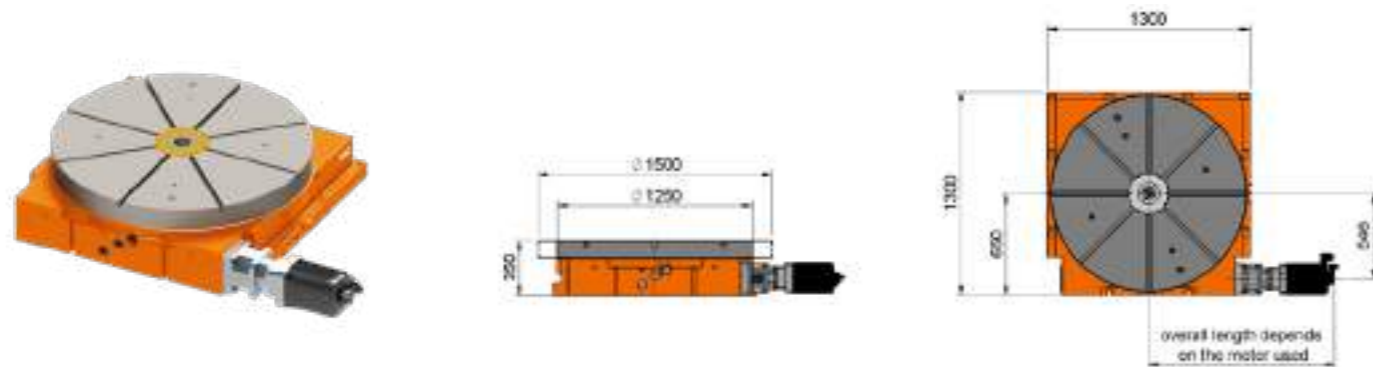

CAD files, technical data and planning documents can be downloaded at [www.fibro.de](http://www.fibro.de)

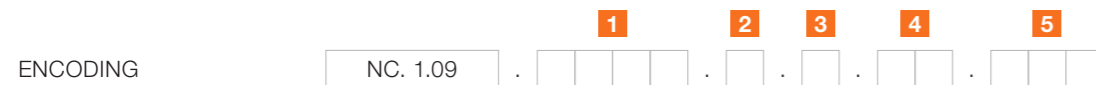

Installation position of standard horizontal table tops (specify other mounting positions on ordering)

### 1 Table top dimensions

Standard dimensions Ø	1,250/1,500
-----------------------	-------------

### 2 Table top design

Rotary	1
Rotary, with T-slots 22H7/H12	2
Square	3
Square, with T-slots 22H7/H12	4
Special version	0

### 3 Table top clamping

Without hydraulic clamping	0	
With hydraulic clamping	1	
Nominal pressure	bar	64
Volume	cm <sup>3</sup>	4
Max. pump capacity	l/min	10

### 4 Measuring system

Preparation for installation of measuring system	0
Delivery with installed measuring system	1
Measuring system at motor provided	2
Direct measuring system	1
Indirect measurement on the motor	4

### 5 Motor arrangement

Preparation for installation of the motor	0
Delivery with installed motor	1
Motor provided by customer	2
Drive on left	L
Drive on right	R
Gear wheel train	Z
Direct	D
Planetary gear	P
Belt train	R
Angular gear box	W
Hand crank	H
Special version	S

## TECHNICAL DATA

Max. centre borehole (special version)	mm	Ø 520
Bearing: inner Ø × outer Ø	mm	850×1,095
Weight with Ø 1,250 mm table top (without motor)	kg	2,500

Special versions available on request

## ACCURACIES

### Direct measuring system

System accuracy in arc seconds	max.	± 1
Indexing accuracy in arc seconds	max.	± 2.5
Indexing accuracy in arc length on Ø 1,250 mm	max.	± 0.008

### Indirect measuring system

Indexing accuracy in arc seconds	max.	± 8
Indexing accuracy in arc length on Ø 1,250 mm	max.	± 0.024

### Geometric accuracies

Runout: centre bore	mm	0.01
Axial runout precision on Ø 1,250 mm	mm	0.02
Plane parallelism of housing/table top related to Ø 1,250 mm	mm	0.04

Higher geometric accuracies available on request

## LOAD DATA

1	Perm. axial loading on table top, horizontal	N	389,000
3	Perm. radial loading on table top	N	310,000
4	Perm. transport load on table top, horizontal	kg	19,000
6	Permissible tilting moment, horizontal on positioned table top on rotating table top	Nm	400,000 Nm 100,000
8	Perm. tangential moment on positioned table top with hydraulic clamping	Nm	32,000
9	Perm. torque limit transferable by standard worm	Nm	17,000

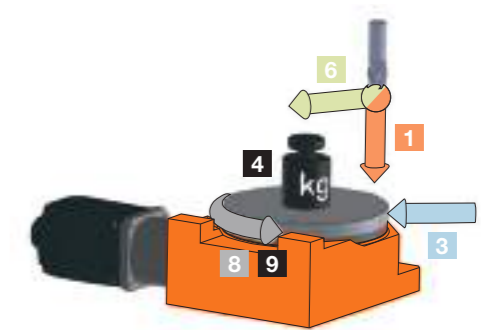

## SAMPLE DESIGN NC. 1.09

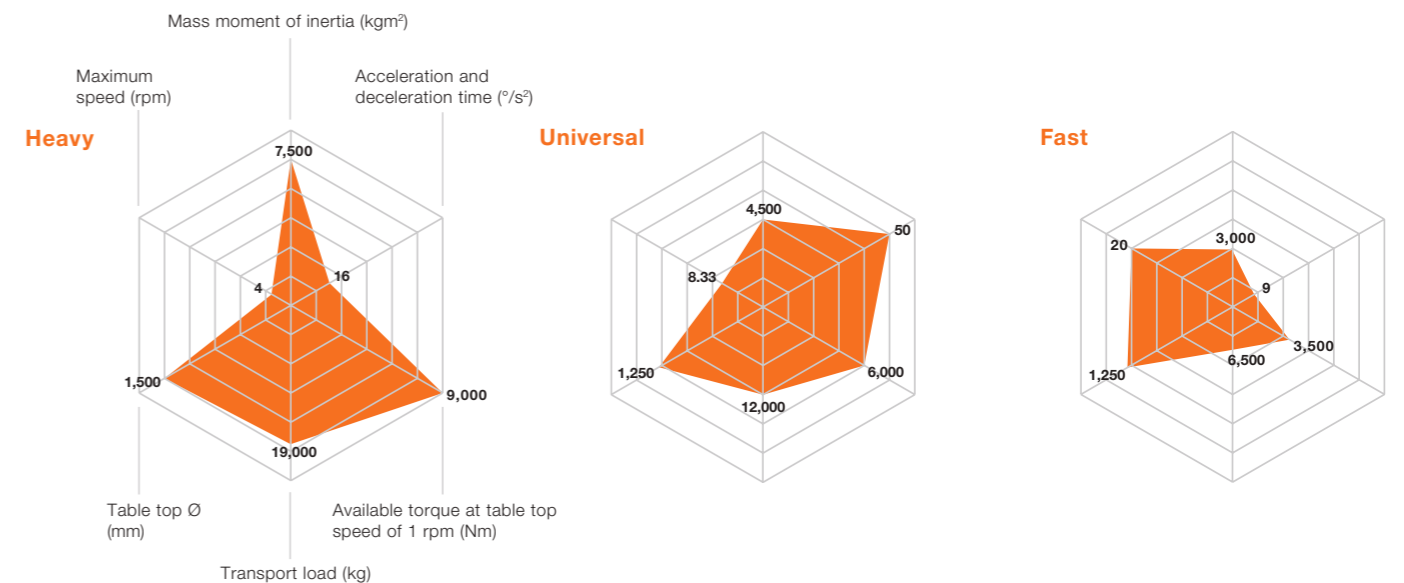

# FIBROPLAN® NC. 1.10

## DIMENSIONS



1 2 3 4 5  
 NC. 1.10 . 1 6 0 0 . 2 . 1 . 1 4 . 1 R P

CAD files, technical data and planning documents can be downloaded at [www.fibro.de](http://www.fibro.de)

ENCODING 1 2 3 4 5  
 NC. 1.10 . . . . .

Installation position of standard horizontal table tops (specify other mounting positions on ordering)

### 1 Table top dimensions

Standard dimensions Ø 1,600

### 2 Table top design

Rotary	1
Rotary, with T-slots 22H7/H12	2
Square	3
Square, with T-slots 22H7/H12	4
Special version	0

### 3 Table top clamping

Without hydraulic clamping	0	
With hydraulic clamping	1	
Nominal pressure	bar	64
Volume	cm <sup>3</sup>	4
Max. pump capacity	l/min	12

### 4 Measuring system

Preparation for installation of measuring system	0
Delivery with installed measuring system	1
Measuring system at motor provided	2
Direct measuring system	1
Indirect measurement on the motor	4

### 5 Motor arrangement

Preparation for installation of the motor	0
Delivery with installed motor	1
Motor provided by customer	2
Drive on left	L
Drive on right	R
Gear wheel train	Z
Direct	D
Planetary gear	P
Belt train	R
Angular gear box	W
Hand crank	H
Special version	S

## TECHNICAL DATA

Max. centre borehole (special version)	mm	Ø 630
Bearing: inner Ø × outer Ø	mm	1,030×1,300
Weight with Ø 1,600 mm table top (without motor)	kg	4,000

Special versions available on request

## ACCURACIES

### Direct measuring system

System accuracy in arc seconds	max.	± 1
Indexing accuracy in arc seconds	max.	± 2.5
Indexing accuracy in arc length on Ø 1,600 mm	max.	±0.010

### Indirect measuring system

Indexing accuracy in arc seconds	max.	± 8
Indexing accuracy in arc length on Ø 1,600 mm	max.	±0.031

### Geometric accuracies

Runout: centre bore	mm	0.01
Axial runout precision on Ø 1,600 mm	mm	0.025
Plane parallelism of housing/table top related to Ø 1,600 mm	mm	0.05

Higher geometric accuracies available on request

## LOAD DATA

1	Perm. axial loading on table top, horizontal	N	822,000
3	Perm. radial loading on table top	N	400,000
4	Perm. transport load on table top, horizontal	kg	40,000
6	Permissible tilting moment, horizontal on positioned table top on rotating table top	Nm	600,000 150,000
8	Perm. tangential moment on positioned table top with hydraulic clamping	Nm	40,000
9	Perm. torque limit transferable by standard worm	Nm	24,000

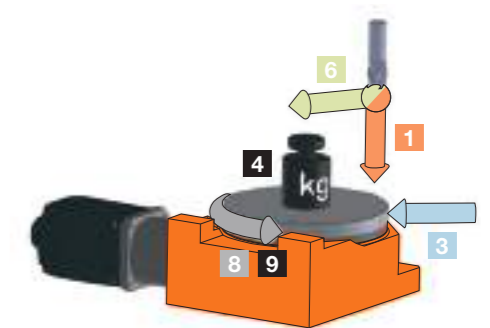

## SAMPLE DESIGN NC. 1.10

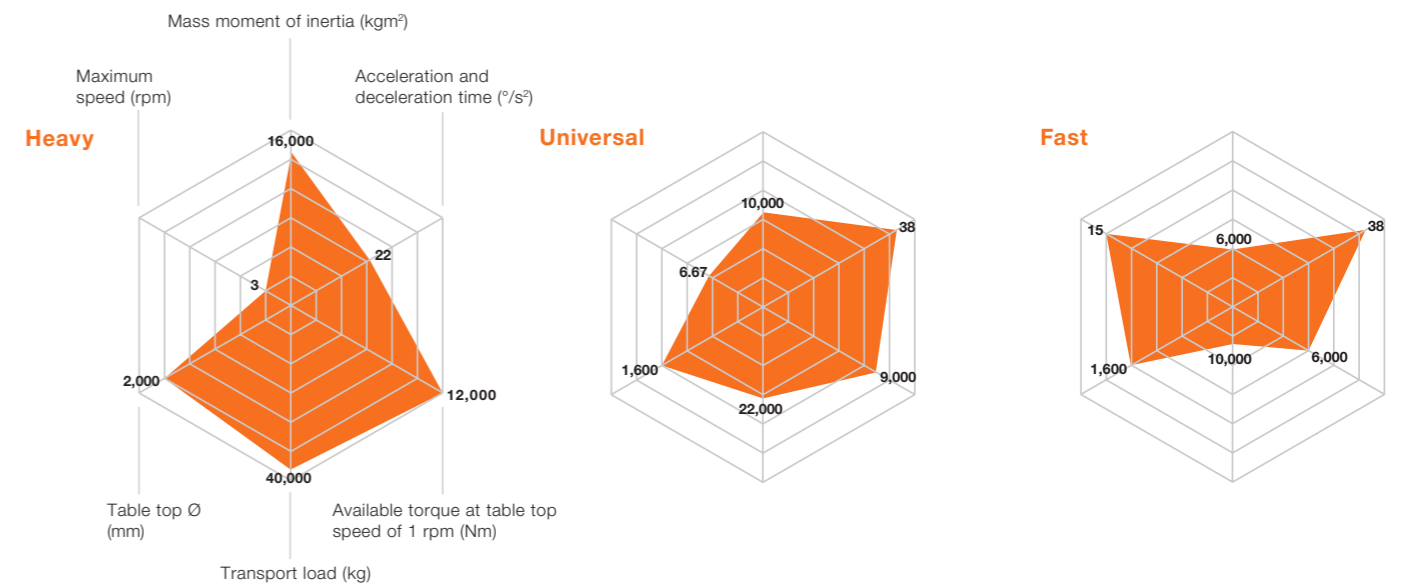

# FIBROPLAN® NC. 2.01

## DIMENSIONS

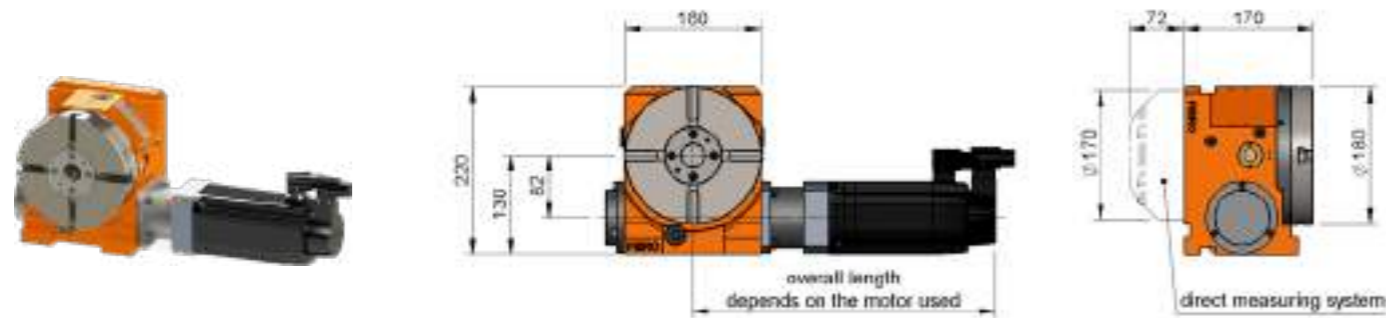

1 2 3 4 5  
 NC. 2.01 . 0 1 8 0 . 2 . 1 . 1 4 . 1 R D

CAD files, technical data and planning documents can be downloaded at [www.fibro.de](http://www.fibro.de)

ENCODING 1 2 3 4 5  
 NC. 2.01 . . . . .

### Installation position of standard horizontal/vertical table tops (specify other mounting positions on ordering)

#### 1 Table top dimensions

Standard dimensions Ø 180

#### 2 Table top design

Rotary	1
Rotary, with T-slots 12H7/H12	2
Square	3
Square, with T-slots 12H7/H12	4
Special version	0

#### 3 Table top clamping

Without hydraulic clamping	0	
With hydraulic clamping	1	
Nominal pressure	bar	64
Volume	cm <sup>3</sup>	2
Max. pump capacity	l/min	2

#### 4 Measuring system

Preparation for installation of measuring system	0
Delivery with installed measuring system	1
Measuring system at motor provided	2
Direct measuring system	1
Indirect measurement on the motor	4

#### 5 Motor arrangement

Preparation for installation of the motor	0
Delivery with installed motor	1
Motor provided by customer	2
Drive on left	L
Drive on right	R
Direct	D
Planetary gear	P
Belt train	R
Angular gear box	W
Hand crank	H
Special version	S

## TECHNICAL DATA

Max. centre borehole (special version)	mm	Ø 25
Bearing: inner Ø × outer Ø	mm	80×150
Weight with Ø 180 mm table top (without motor)	kg	45

Special versions available on request

## ACCURACIES

### Direct measuring system

System accuracy in arc seconds	max.	± 1
Indexing accuracy in arc seconds	max.	± 2.5
Indexing accuracy in arc length on Ø 180 mm	max.	± 0.001

### Indirect measuring system

Indexing accuracy in arc seconds	max.	± 20
Indexing accuracy in arc length on Ø 180 mm	max.	± 0.009

### Geometric accuracies

Runout: centre bore	mm	0.01
Axial runout precision on Ø 180 mm	mm	0.01
Plane parallelism of housing/table top related to Ø 180 mm	mm	0.02

Higher geometric accuracies available on request

## LOAD DATA

2	Perm. axial loading on table top, vertical	N	5,000
3	Perm. radial loading on table top	N	13,000
5	Perm. transport load on table top, vertical (flying load)	kg	150
5	Perm. support load on table top, vertical (with counter bearing)	kg	450
6	Permissible tilting moment, horizontal on positioned table top	Nm	2,000
6	Permissible tilting moment, horizontal on rotating table top	Nm	500
7	Permissible tilting moment, vertical on positioned table top	Nm	1,500
7	Permissible tilting moment, vertical on rotating table top	Nm	375
8	Perm. tangential moment on positioned table top with hydraulic clamping	Nm	700
9	Perm. torque limit transferable by standard worm	Nm	300

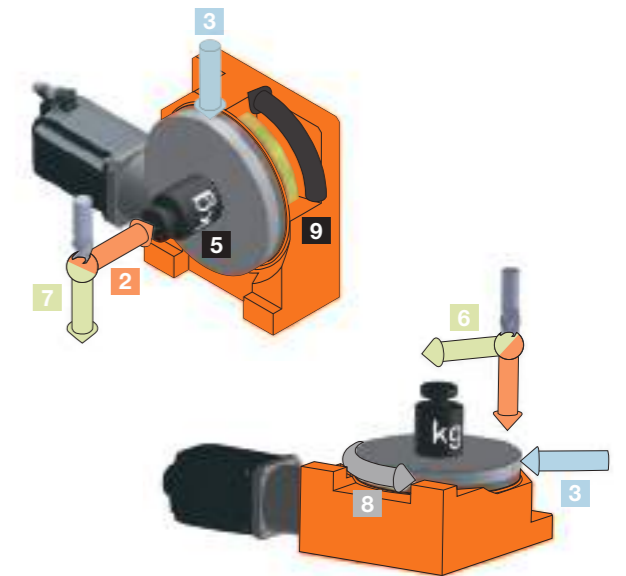

## SAMPLE DESIGN NC. 2.01

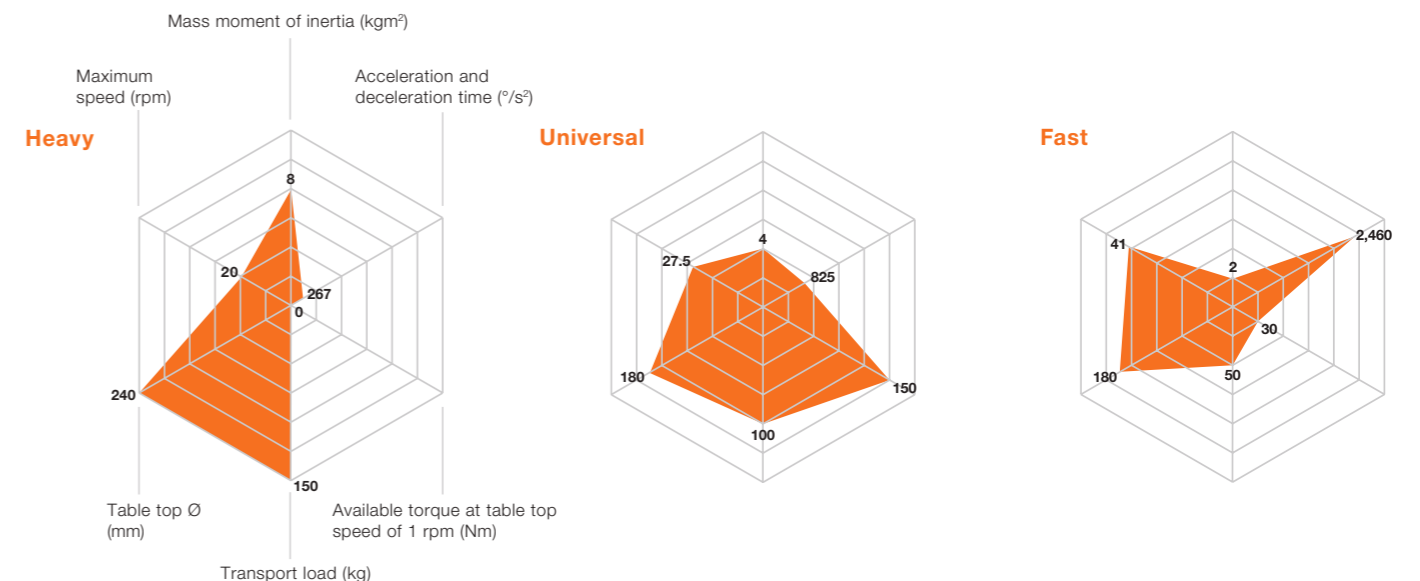



# FIBROPLAN® NC. 2.05

## DIMENSIONS

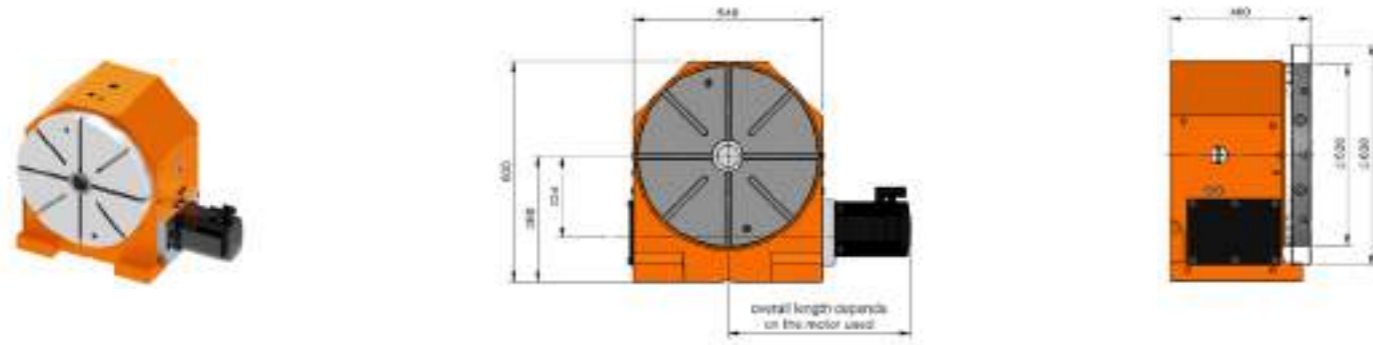

1 2 3 4 5  
 NC. 2.05 . 0 5 2 0 . 2 . 1 . 1 4 . 1 R Z

CAD files, technical data and planning documents can be downloaded at [www.fibro.de](http://www.fibro.de)

ENCODING 1 2 3 4 5  
 NC. 2.05 . . . . .

Installation position of standard vertical table tops (specify other mounting positions on ordering)

### 1 Table top dimensions

Standard dimensions Ø 520/630

### 2 Table top design

Rotary	1
Rotary, with T-slots 14H7/H12	2
Square	3
Square, with T-slots 14H7/H12	4
Special version	0

### 3 Table top clamping

Without hydraulic clamping	0	
With hydraulic clamping	1	
Nominal pressure	bar	64
Volume	cm <sup>3</sup>	16
Max. pump capacity	l/min	8

### 4 Measuring system

Preparation for installation of measuring system	0
Delivery with installed measuring system	1
Measuring system at motor provided	2
Direct measuring system	1
Indirect measurement on the motor	4

### 5 Motor arrangement

Preparation for installation of the motor	0
Delivery with installed motor	1
Motor provided by customer	2
Drive on left	L
Drive on right	R
Gear wheel train	Z
Direct	D
Planetary gear	P
Belt train	R
Angular gear box	W
Hand crank	H
Special version	S

## TECHNICAL DATA

Max. centre borehole (special version)	mm	Ø 140
Bearing: inner Ø × outer Ø	mm	325×450
Weight with Ø 520 mm table top (without motor)	kg	500

Special versions available on request

## ACCURACIES

### Direct measuring system

System accuracy in arc seconds	max.	± 1
Indexing accuracy in arc seconds	max.	± 2.5
Indexing accuracy in arc length on Ø 520 mm	max.	± 0.003

### Indirect measuring system

Indexing accuracy in arc seconds	max.	± 10
Indexing accuracy in arc length on Ø 520 mm	max.	± 0.013

### Geometric accuracies

Runout: centre bore	mm	0.01
Axial runout precision on Ø 520 mm	mm	0.012
Plane parallelism of housing/table top related to Ø 520 mm	mm	0.025

Higher geometric accuracies available on request

## LOAD DATA

2	Perm. axial loading on table top, vertical	N	45,000
3	Perm. radial loading on table top	N	67,000
5	Perm. transport load on table top, vertical (flying load)	kg	1,200
5	Perm. support load on table top, vertical (with counter bearing)	kg	3,600
7	Permissible tilting moment, vertical on positioned table top	Nm	16,000
7	Permissible tilting moment, vertical on rotating table top	Nm	4,000
8	Perm. tangential moment on positioned table top with hydraulic clamping	Nm	6,000
9	Perm. torque limit transferable by standard worm	Nm	4,200

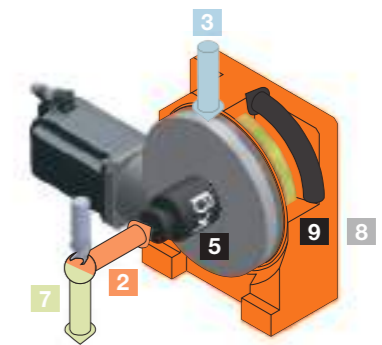

## SAMPLE DESIGN NC. 2.05

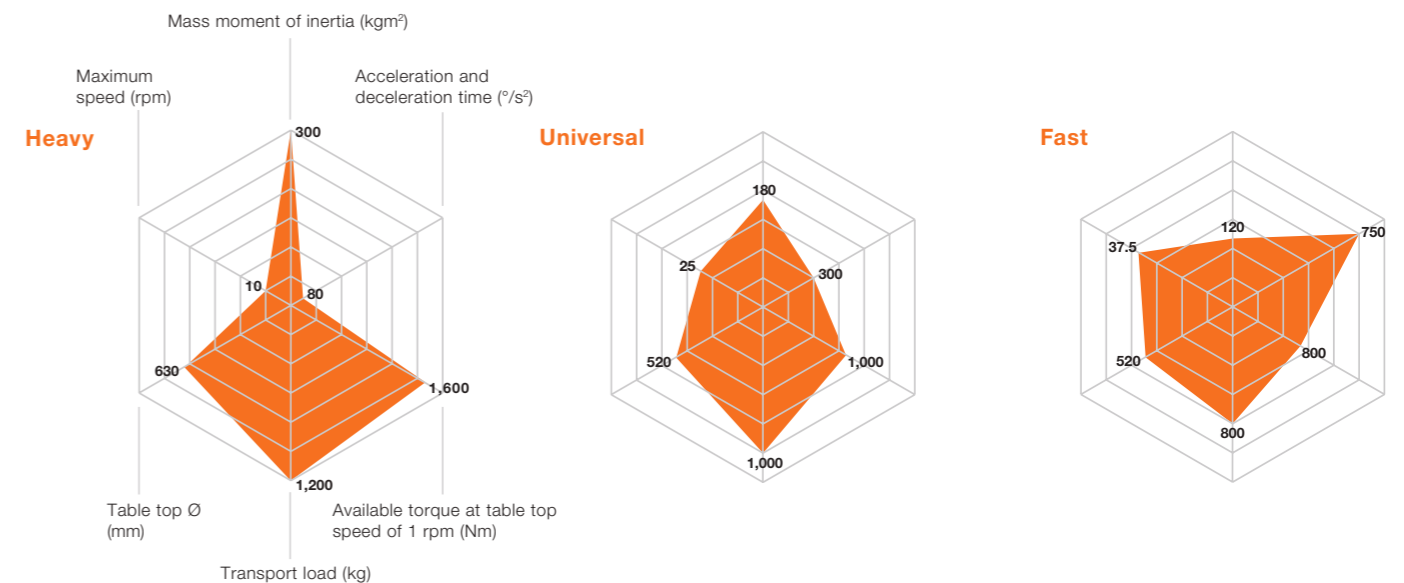

# FIBROPLAN® NC. 2.06

## DIMENSIONS

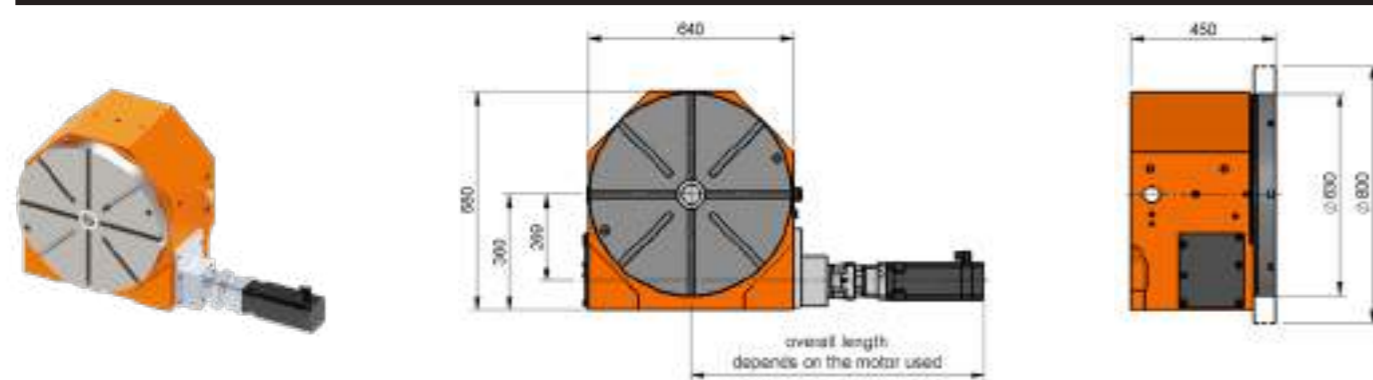

1 2 3 4 5  
 NC. 2.06 . 0 6 3 0 . 2 . 1 . 1 4 . 1 R P

CAD files, technical data and planning documents can be downloaded at [www.fibro.de](http://www.fibro.de)

ENCODING 1 2 3 4 5  
 NC. 2.06 . . . . .

Installation position of standard vertical table tops (specify other mounting positions on ordering)

### 1 Table top dimensions

Standard dimensions Ø 630/800

### 2 Table top design

Rotary	1
Rotary, with T-slots 18H7/H12	2
Square	3
Square, with T-slots 18H7/H12	4
Special version	0

### 3 Table top clamping

Without hydraulic clamping	0	
With hydraulic clamping	1	
Nominal pressure	bar	64
Volume	cm <sup>3</sup>	20
Max. pump capacity	l/min	10

### 4 Measuring system

Preparation for installation of measuring system	0
Delivery with installed measuring system	1
Measuring system at motor provided	2
Direct measuring system	1
Indirect measurement on the motor	4

### 5 Motor arrangement

Preparation for installation of the motor	0
Delivery with installed motor	1
Motor provided by customer	2
Drive on left	L
Drive on right	R
Gear wheel train	Z
Direct	D
Planetary gear	P
Belt train	R
Angular gear box	W
Hand crank	H
Special version	S

## TECHNICAL DATA

Max. centre borehole (special version)	mm	Ø 190
Bearing: inner Ø × outer Ø	mm	460×600
Weight with Ø 630 mm table top (without motor)	kg	700

Special versions available on request

## ACCURACIES

### Direct measuring system

System accuracy in arc seconds	max.	± 1
Indexing accuracy in arc seconds	max.	± 2.5
Indexing accuracy in arc length on Ø 630 mm	max.	± 0.004

### Indirect measuring system

Indexing accuracy in arc seconds	max.	± 10
Indexing accuracy in arc length on Ø 630 mm	max.	± 0.015

### Geometric accuracies

Runout: centre bore	mm	0.01
Axial runout precision on Ø 630 mm	mm	0.015
Plane parallelism of housing/table top related to Ø 630 mm	mm	0.03

Higher geometric accuracies available on request

## LOAD DATA

2	Perm. axial loading on table top, vertical	N	75,000
3	Perm. radial loading on table top	N	115,000
5	Perm. transport load on table top, vertical (flying load)	kg	2,000
5	Perm. support load on table top, vertical (with counter bearing)	kg	6,000
7	Permissible tilting moment, vertical on positioned table top	Nm	26,000
7	on rotating table top	Nm	6,500
8	Perm. tangential moment on positioned table top with hydraulic clamping	Nm	8,000
9	Perm. torque limit transferable by standard worm	Nm	7,000

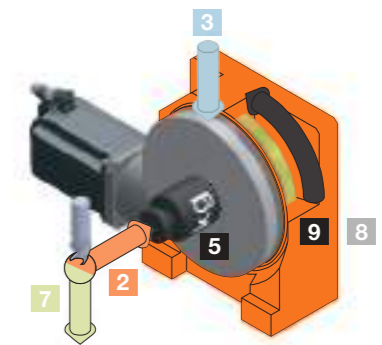

## SAMPLE DESIGN NC. 2.06

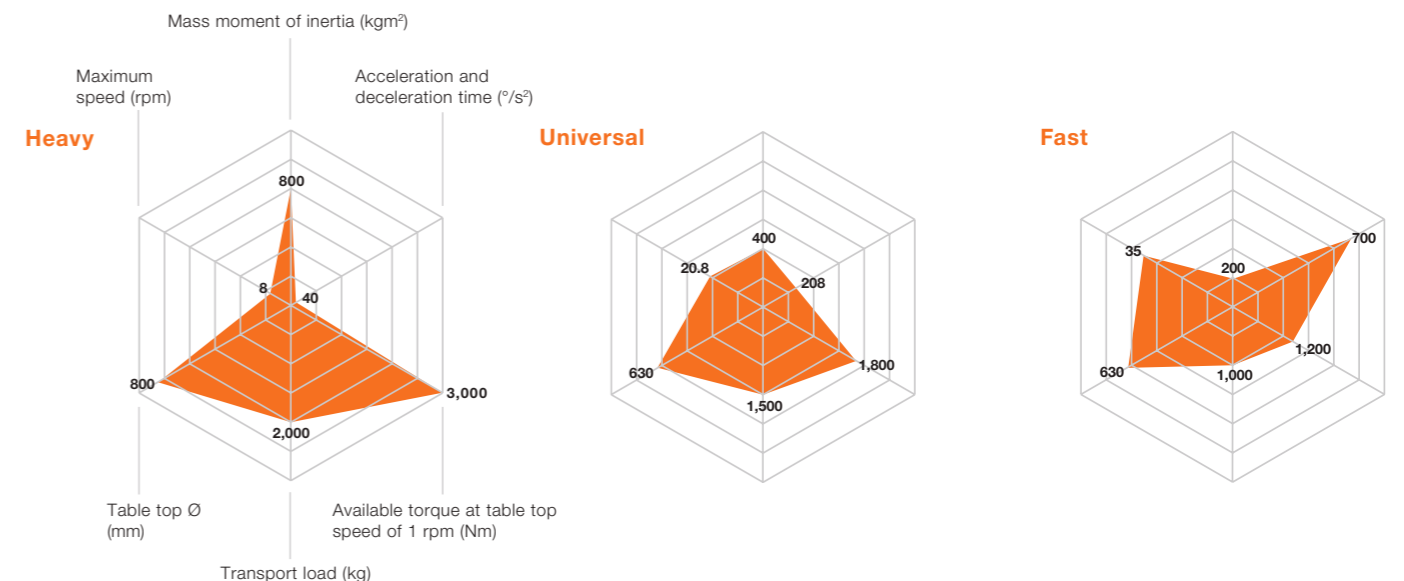

# FIBROPLAN® NC. 2.07

## DIMENSIONS

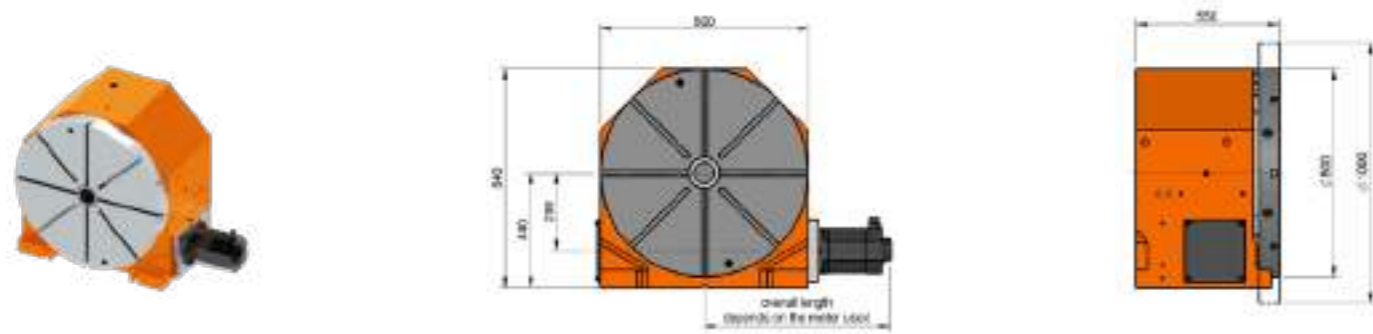

1 2 3 4 5  
 NC. 2.07 . 0 8 0 0 . 2 . 1 . 1 4 . 1 R Z

CAD files, technical data and planning documents can be downloaded at [www.fibro.de](http://www.fibro.de)

ENCODING 1 2 3 4 5  
 NC. 2.07 . . . . .

Installation position of standard vertical table tops (specify other mounting positions on ordering)

### 1 Table top dimensions

Standard dimensions Ø 800/1,000

### 2 Table top design

Rotary	1
Rotary, with T-slots 18H7/H12	2
Square	3
Square, with T-slots 18H7/H12	4
Special version	0

### 3 Table top clamping

Without hydraulic clamping	0	
With hydraulic clamping	1	
Nominal pressure	bar	64
Volume	cm <sup>3</sup>	25
Max. pump capacity	l/min	12

### 4 Measuring system

Preparation for installation of measuring system	0
Delivery with installed measuring system	1
Measuring system at motor provided	2
Direct measuring system	1
Indirect measurement on the motor	4

### 5 Motor arrangement

Preparation for installation of the motor	0
Delivery with installed motor	1
Motor provided by customer	2
Drive on left	L
Drive on right	R
Gear wheel train	Z
Direct	D
Planetary gear	P
Belt train	R
Angular gear box	W
Hand crank	H
Special version	S

## TECHNICAL DATA

Max. centre borehole (special version)	mm	Ø 250
Bearing: inner Ø × outer Ø	mm	580×750
Weight with Ø 800 mm table top (without motor)	kg	1,250

Special versions available on request

## ACCURACIES

### Direct measuring system

System accuracy in arc seconds	max.	± 1
Indexing accuracy in arc seconds	max.	± 2.5
Indexing accuracy in arc length on Ø 800 mm	max.	± 0.005

### Indirect measuring system

Indexing accuracy in arc seconds	max.	± 8
Indexing accuracy in arc length on Ø 800 mm	max.	± 0.016

### Geometric accuracies

Runout: centre bore	mm	0.01
Axial runout precision on Ø 800 mm	mm	0.015
Plane parallelism of housing/table top related to Ø 800 mm	mm	0.03

Higher geometric accuracies available on request

## LOAD DATA

2	Perm. axial loading on table top, vertical	N	100,000
3	Perm. radial loading on table top	N	140,000
5	Perm. transport load on table top, vertical (flying load)	kg	3,000
5	Perm. support load on table top, vertical (with counter bearing)	kg	9,000
7	Permissible tilting moment, vertical on positioned table top	Nm	32,500
7	Permissible tilting moment, vertical on rotating table top	Nm	8,125
8	Perm. tangential moment on positioned table top with hydraulic clamping	Nm	14,000
9	Perm. torque limit transferable by standard worm	Nm	7,900

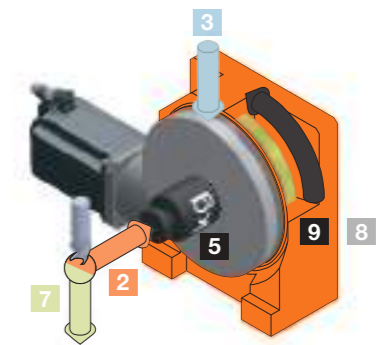

## SAMPLE DESIGN NC. 2.07

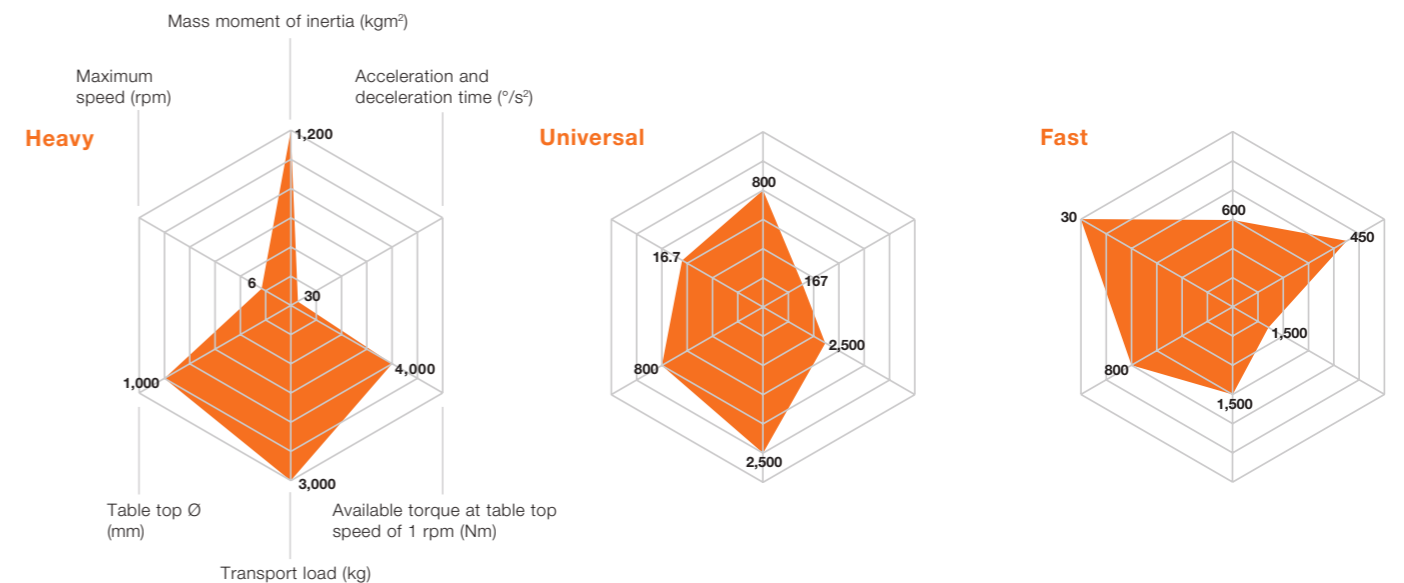

# FIBROPLAN® NC. 2.08

## DIMENSIONS

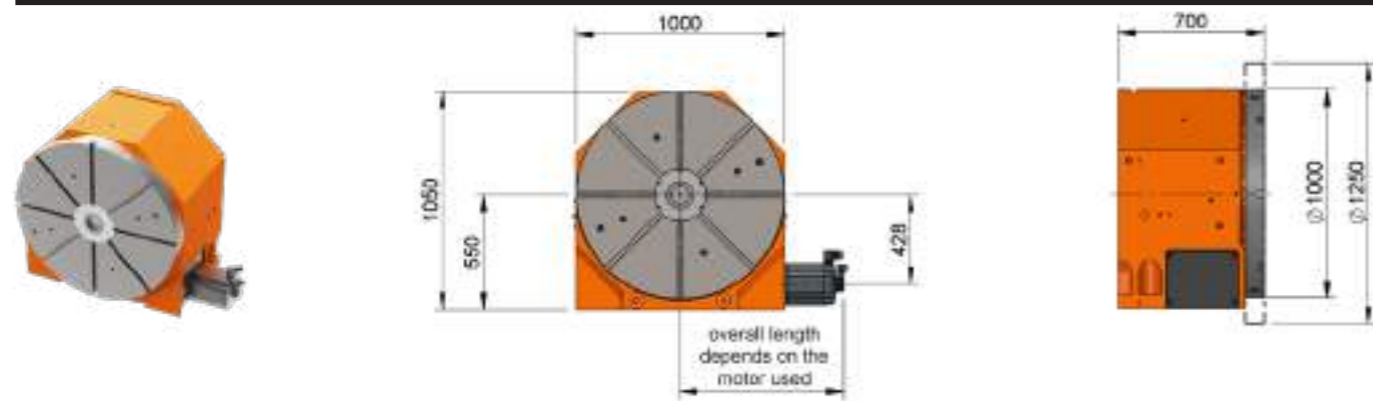

1 2 3 4 5  
 NC. 2.08 . 1 0 0 0 . 2 . 1 . 1 4 . 1 R P

CAD files, technical data and planning documents can be downloaded at [www.fibro.de](http://www.fibro.de)

ENCODING 1 2 3 4 5  
 NC. 2.08 . . . . .

Installation position of standard vertical table tops (specify other mounting positions on ordering)

### 1 Table top dimensions

Standard dimensions Ø 1,000/1,250

### 2 Table top design

Rotary	1
Rotary, with T-slots 22H7/H12	2
Square	3
Square, with T-slots 22H7/H12	4
Special version	0

### 3 Table top clamping

Without hydraulic clamping	0	
With hydraulic clamping	1	
Nominal pressure	bar	64
Volume	cm <sup>3</sup>	30
Max. pump capacity	l/min	14

### 4 Measuring system

Preparation for installation of measuring system	0
Delivery with installed measuring system	1
Measuring system at motor provided	2
Direct measuring system	1
Indirect measurement on the motor	4

### 5 Motor arrangement

Preparation for installation of the motor	0
Delivery with installed motor	1
Motor provided by customer	2
Drive on left	L
Drive on right	R
Gear wheel train	Z
Direct	D
Planetary gear	P
Belt train	R
Angular gear box	W
Hand crank	H
Special version	S

## TECHNICAL DATA

Max. centre borehole (special version)	mm	Ø 420
Bearing: inner Ø × outer Ø	mm	650×870
Weight with Ø 1,000 mm table top (without motor)	kg	2,300

Special versions available on request

## ACCURACIES

### Direct measuring system

System accuracy in arc seconds	max.	± 1
Indexing accuracy in arc seconds	max.	± 2.5
Indexing accuracy in arc length on Ø 1,000 mm	max.	± 0.006

### Indirect measuring system

Indexing accuracy in arc seconds	max.	± 8
Indexing accuracy in arc length on Ø 1,000 mm	max.	± 0.019

### Geometric accuracies

Runout: centre bore	mm	0.01
Axial runout precision on Ø 1,000 mm	mm	0.02
Plane parallelism of housing/table top related to Ø 1,000 mm	mm	0.04

Higher geometric accuracies available on request

## LOAD DATA

2	Perm. axial loading on table top, vertical	N	120,000
3	Perm. radial loading on table top	N	250,000
5	Perm. transport load on table top, vertical (flying load)	kg	6,000
5	Perm. support load on table top, vertical (with counter bearing)	kg	18,000
7	Permissible tilting moment, vertical on positioned table top	Nm	57,500
7	Permissible tilting moment, vertical on rotating table top	Nm	14,375
8	Perm. tangential moment on positioned table top with hydraulic clamping	Nm	25,000
9	Perm. torque limit transferable by standard worm	Nm	14,000

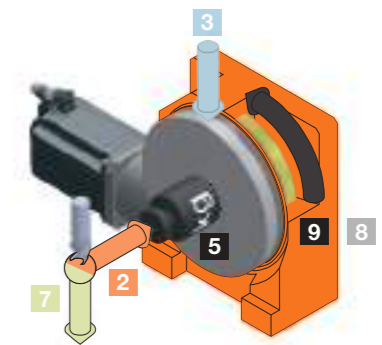

## SAMPLE DESIGN NC. 2.08

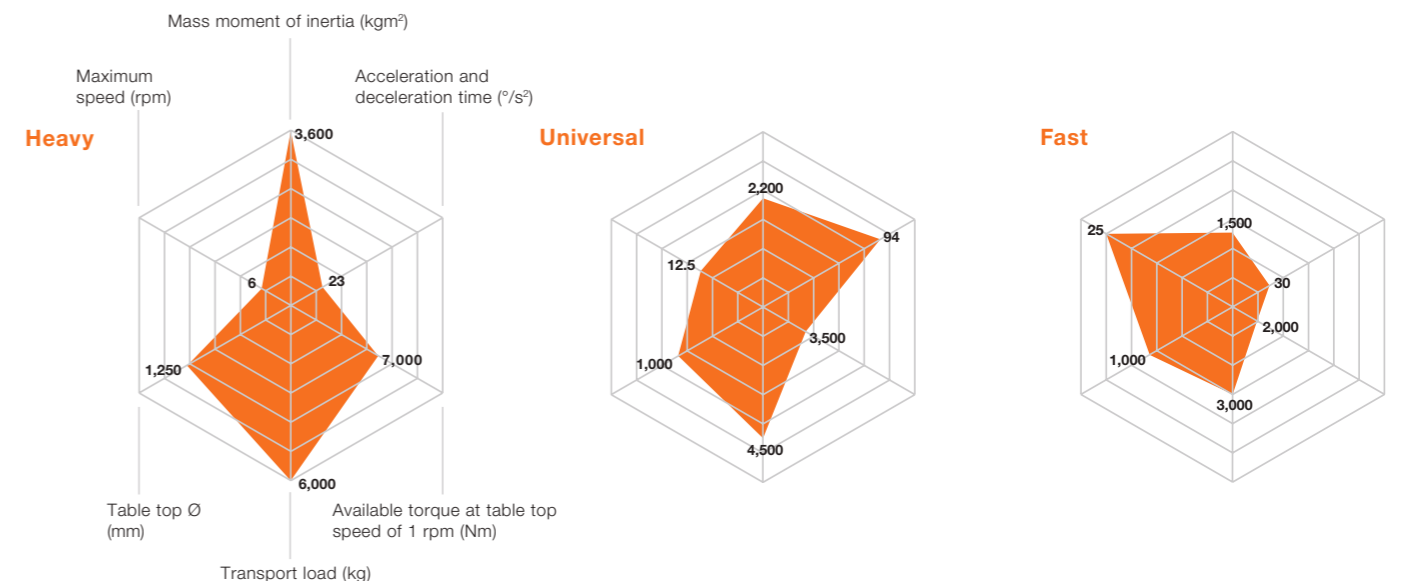

# FIBROPLAN® NC. 2.09

## DIMENSIONS

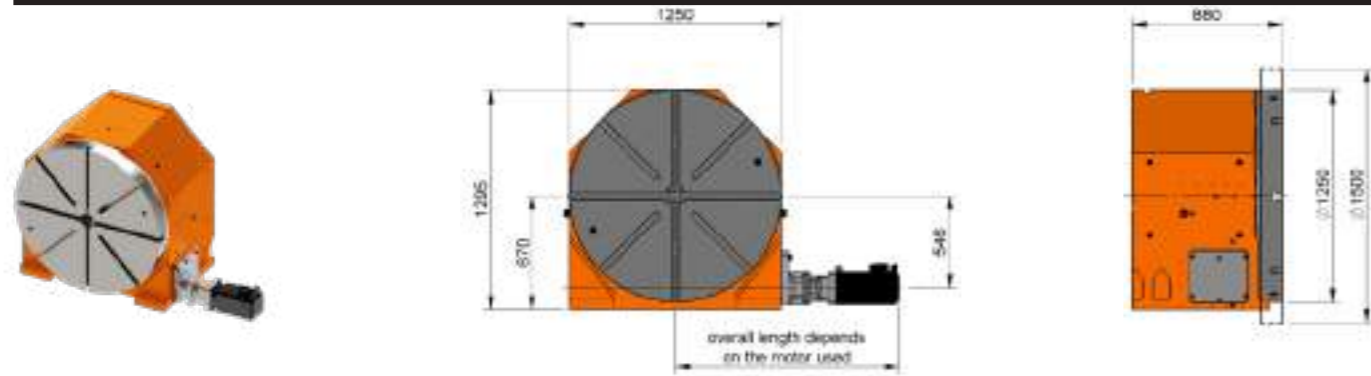

1 2 3 4 5  
 NC. 2.09 . 1 2 5 0 . 2 . 1 . 1 4 . 1 R P

CAD files, technical data and planning documents can be downloaded at [www.fibro.de](http://www.fibro.de)

ENCODING 1 2 3 4 5  
 NC. 2.09 . . . . .

### Installation position of standard vertical table tops (specify other mounting positions on ordering)

#### 1 Table top dimensions

Standard dimensions Ø	1,250/1,500
-----------------------	-------------

#### 2 Table top design

Rotary	1
Rotary, with T-slots 22H7/H12	2
Square	3
Square, with T-slots 22H7/H12	4
Special version	0

#### 3 Table top clamping

Without hydraulic clamping	0	
With hydraulic clamping	1	
Nominal pressure	bar	64
Volume	cm <sup>3</sup>	40
Max. pump capacity	l/min	20

#### 4 Measuring system

Preparation for installation of measuring system	0
Delivery with installed measuring system	1
Measuring system at motor provided	2
Direct measuring system	1
Indirect measurement on the motor	4

#### 5 Motor arrangement

Preparation for installation of the motor	0
Delivery with installed motor	1
Motor provided by customer	2
Drive on left	L
Drive on right	R
Gear wheel train	Z
Direct	D
Planetary gear	P
Belt train	R
Angular gear box	W
Hand crank	H
Special version	S

## TECHNICAL DATA

Max. centre borehole (special version)	mm	Ø 520
Bearing: inner Ø × outer Ø	mm	850×1,095
Weight with Ø 1,250 mm table top (without motor)	kg	4,000

Special versions available on request

## ACCURACIES

### Direct measuring system

System accuracy in arc seconds	max.	± 1
Indexing accuracy in arc seconds	max.	± 2.5
Indexing accuracy in arc length on Ø 1,250 mm	max.	± 0.008

### Indirect measuring system

Indexing accuracy in arc seconds	max.	± 8
Indexing accuracy in arc length on Ø 1,250 mm	max.	± 0.024

### Geometric accuracies

Runout: centre bore	mm	0.01
Axial runout precision on Ø 1,250 mm	mm	0.02
Plane parallelism of housing/table top related to Ø 1,250 mm	mm	0.04

Higher geometric accuracies available on request

## LOAD DATA

2	Perm. axial loading on table top, vertical	N	160,000
3	Perm. radial loading on table top	N	310,000
5	Perm. transport load on table top, vertical (flying load)	kg	8,000
5	Perm. support load on table top, vertical (with counter bearing)	kg	24,000
7	Permissible tilting moment, vertical on positioned table top	Nm	100,000
7	Permissible tilting moment, vertical on rotating table top	Nm	25,000
8	Perm. tangential moment on positioned table top with hydraulic clamping	Nm	32,000
9	Perm. torque limit transferable by standard worm	Nm	17,000

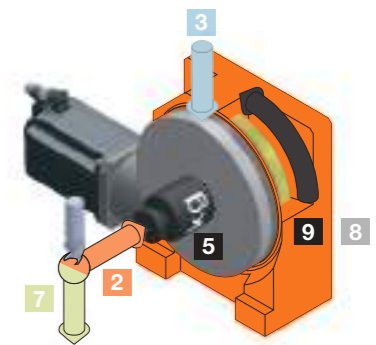

## SAMPLE DESIGN NC. 2.09

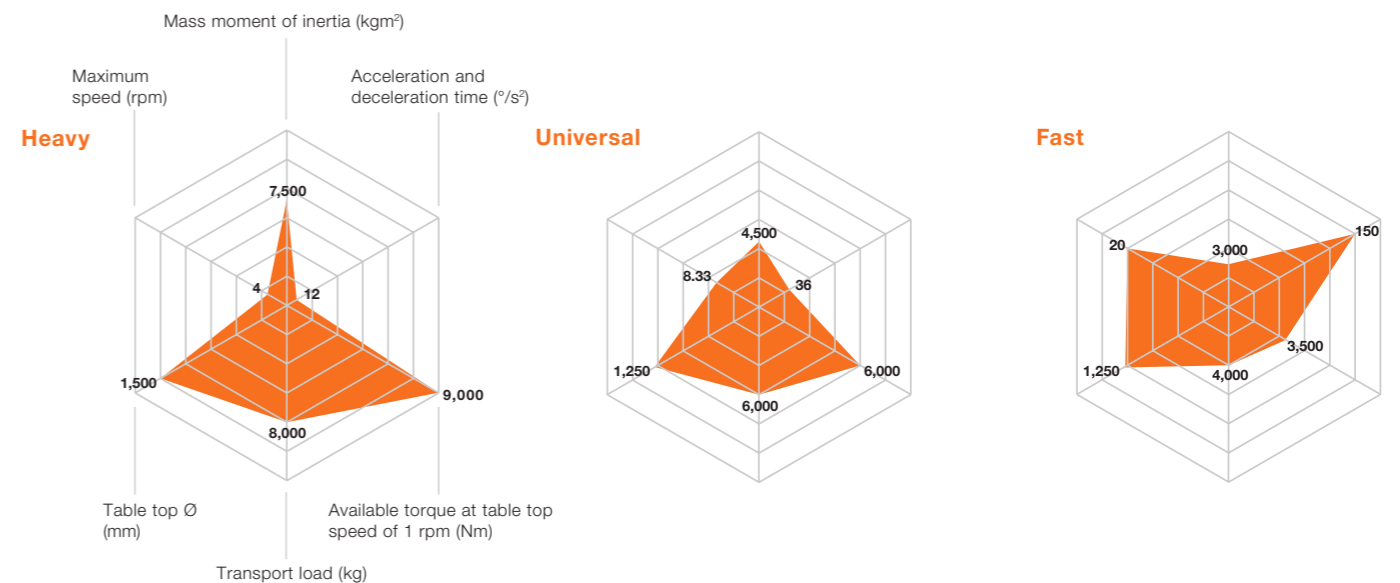

# FIBROPLAN® NC. 2.10

## DIMENSIONS

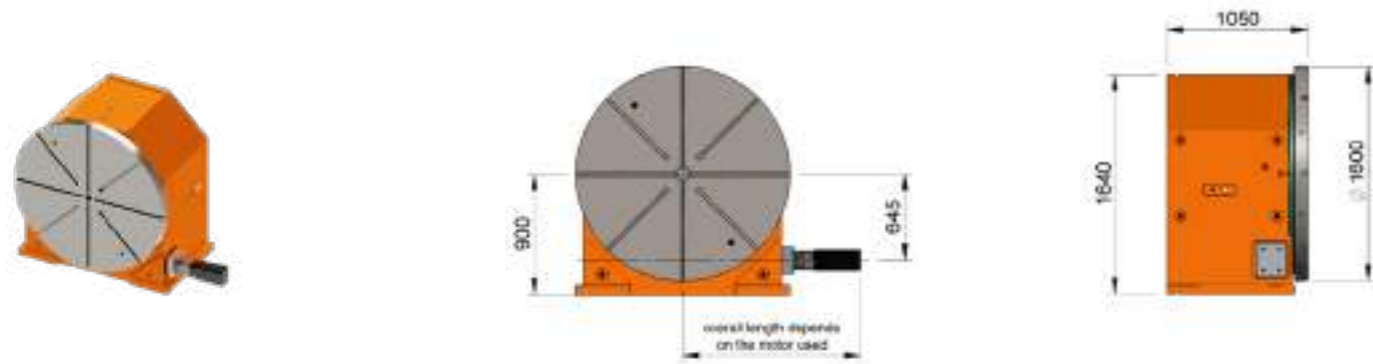

1 2 3 4 5  
 NC. 2.10 . 1 6 0 0 . 2 . 1 . 1 4 . 1 R P

CAD files, technical data and planning documents can be downloaded at [www.fibro.de](http://www.fibro.de)

ENCODING 1 2 3 4 5  
 NC. 2.10 . . . . .

Installation position of standard vertical table tops (specify other mounting positions on ordering)

### 1 Table top dimensions

Standard dimensions Ø 1,600

### 2 Table top design

Rotary	1
Rotary, with T-slots 22H7/H12	2
Square	3
Square, with T-slots 22H7/H12	4
Special version	0

### 3 Table top clamping

Without hydraulic clamping	0	
With hydraulic clamping	1	
Nominal pressure	bar	64
Volume	cm <sup>3</sup>	50
Max. pump capacity	l/min	24

### 4 Measuring system

Preparation for installation of measuring system	0
Delivery with installed measuring system	1
Measuring system at motor provided	2
Direct measuring system	1
Indirect measurement on the motor	4

### 5 Motor arrangement

Preparation for installation of the motor	0
Delivery with installed motor	1
Motor provided by customer	2
Drive on left	L
Drive on right	R
Gear wheel train	Z
Direct	D
Planetary gear	P
Belt train	R
Angular gear box	W
Hand crank	H
Special version	S

## TECHNICAL DATA

Max. centre borehole (special version)	mm	Ø 630
Bearing: inner Ø × outer Ø	mm	1,030×1,300
Weight with Ø 1,600 mm table top (without motor)	kg	5,500

Special versions available on request

## ACCURACIES

### Direct measuring system

System accuracy in arc seconds	max.	± 1
Indexing accuracy in arc seconds	max.	± 2.5
Indexing accuracy in arc length on Ø 1,600 mm	max.	± 0.010

### Indirect measuring system

Indexing accuracy in arc seconds	max.	± 8
Indexing accuracy in arc length on Ø 1,600 mm	max.	± 0.031

### Geometric accuracies

Runout: centre bore	mm	0.01
Axial runout precision on Ø 1,600 mm	mm	0.025
Plane parallelism of housing/table top related to Ø 1,600 mm	mm	0.05

Higher geometric accuracies available on request

## LOAD DATA

2	Perm. axial loading on table top, vertical	N	200,000
3	Perm. radial loading on table top	N	400,000
5	Perm. transport load on table top, vertical (flying load)	kg	12,000
5	Perm. support load on table top, vertical (with counter bearing)	kg	36,000
7	Permissible tilting moment, vertical on positioned table top	Nm	150,000
7	Permissible tilting moment, vertical on rotating table top	Nm	37,500
8	Perm. tangential moment on positioned table top with hydraulic clamping	Nm	40,000
9	Perm. torque limit transferable by standard worm	Nm	24,000

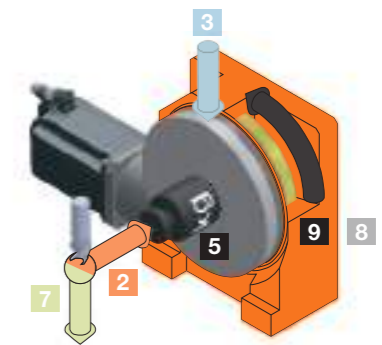

## SAMPLE DESIGN NC. 2.10

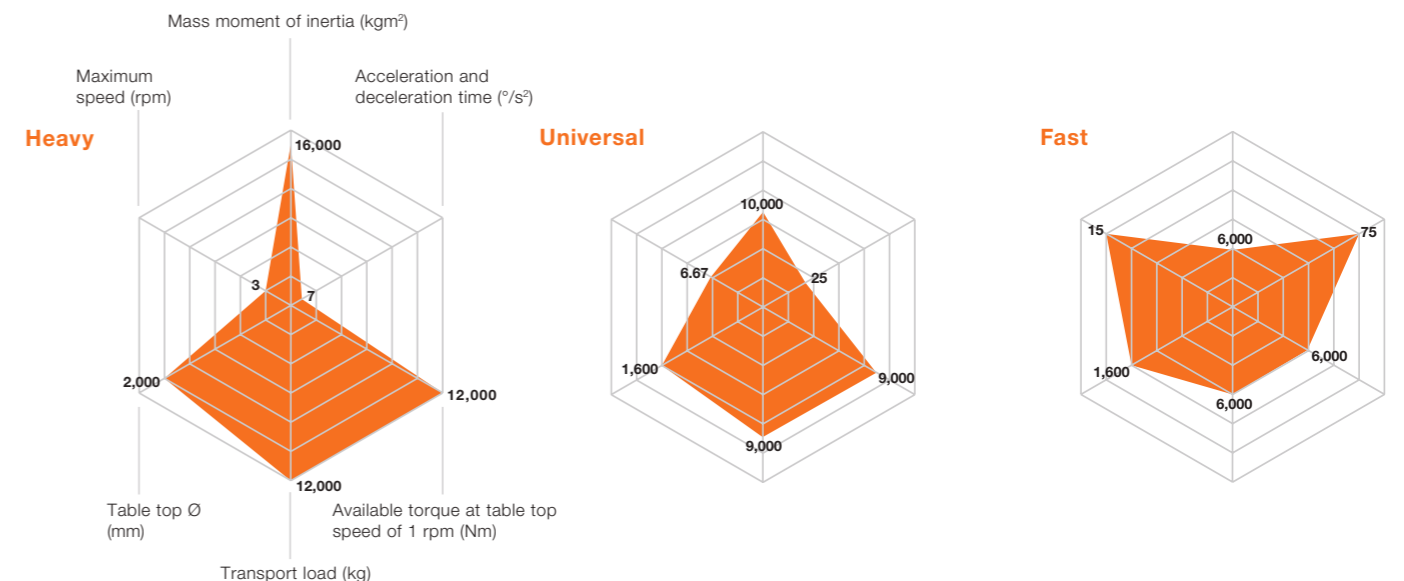

# ACCESSORIES

## COUNTER BEARING

- Available in different sizes
- Centre height according to customer needs
- With hydraulic clamping
- Optional: with rotary distributor for media feed-through

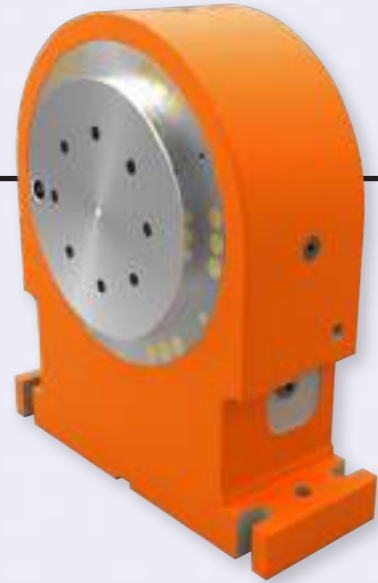

## ROTARY DISTRIBUTOR

- For different mediums
- Integrated into rotary table or counter bearing
- Customised solutions



## TAILSTOCKS

- Available in different sizes
- Operated manually or hydraulically
- Work centre MT1–MT6
- Centre height according to customer needs

## HYDRAULIC UNIT

- For operation of rotary table clamping
- Mounted directly at rotary table or supplied as separate item

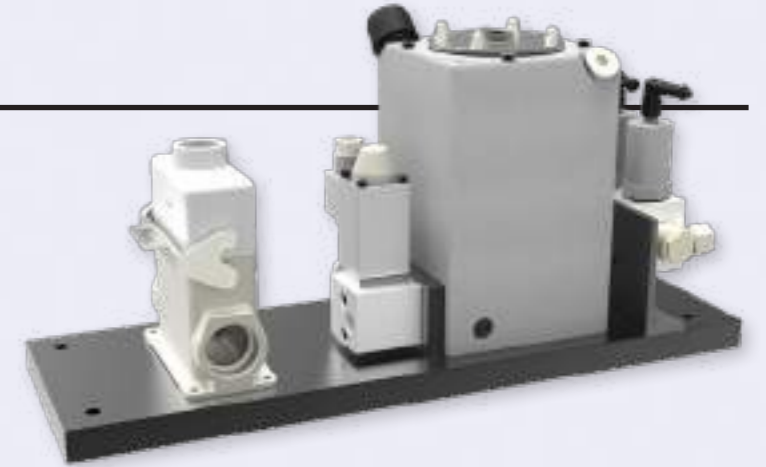

## HYDRAULIC-FAST-CLAMP-BLOCK

- For extremely short clamping times
- Mounted directly at rotary table or supplied as separate item

# SPECIAL SOLUTIONS ROTARY TABLE/MULTI-AXIS COMBINATIONS

# SPECIAL SOLUTIONS ROTARY-LINEAR TABLES

EXAMPLE SPECIAL SOLUTION

Rotary table/multi-axis combination 1

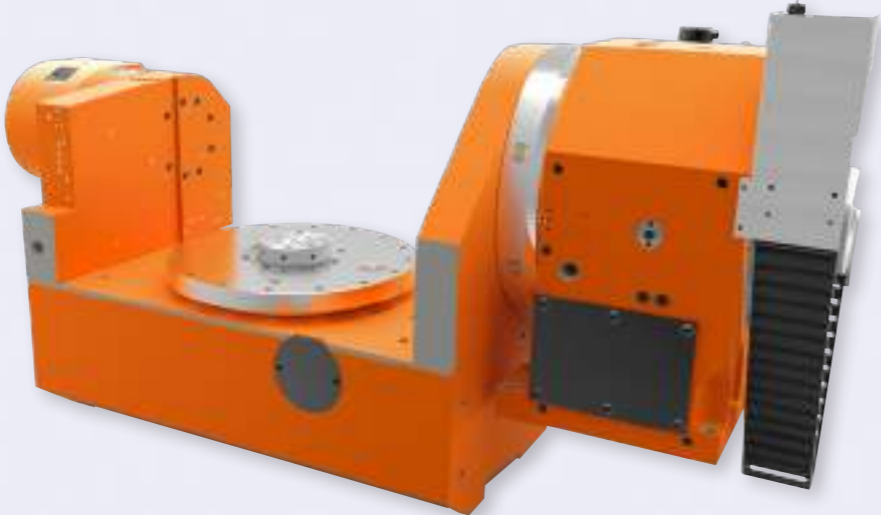

EXAMPLE SPECIAL SOLUTION

Rotary-linear table 1

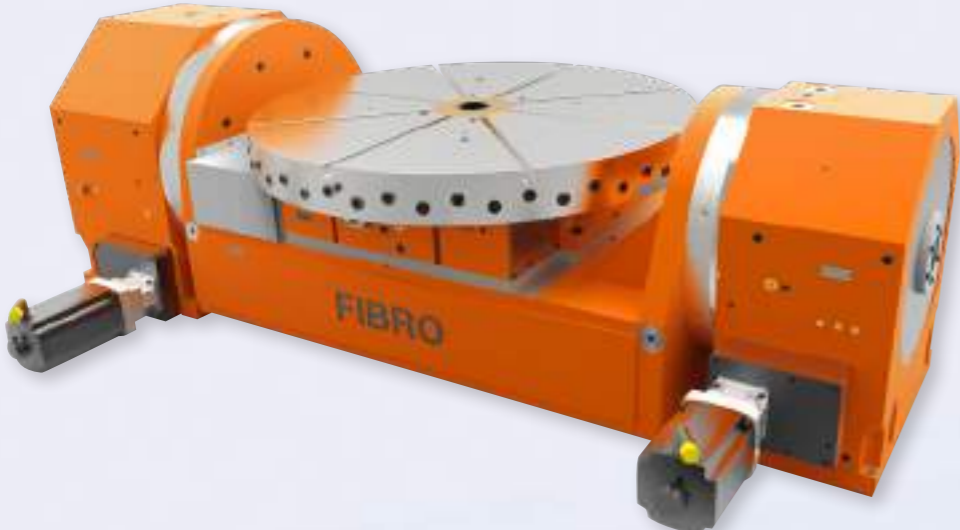

EXAMPLE SPECIAL SOLUTION

Rotary table/multi-axis combination 2

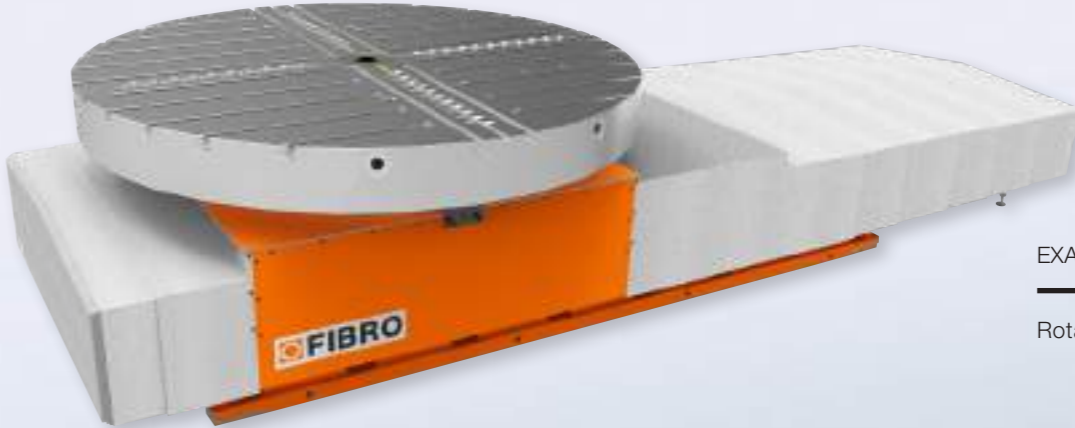

EXAMPLE SPECIAL SOLUTION

Rotary-linear table 2



EXAMPLE SPECIAL SOLUTION

Rotary table/multi-axis combination 3

EXAMPLE SPECIAL SOLUTION

Rotary-linear table 3

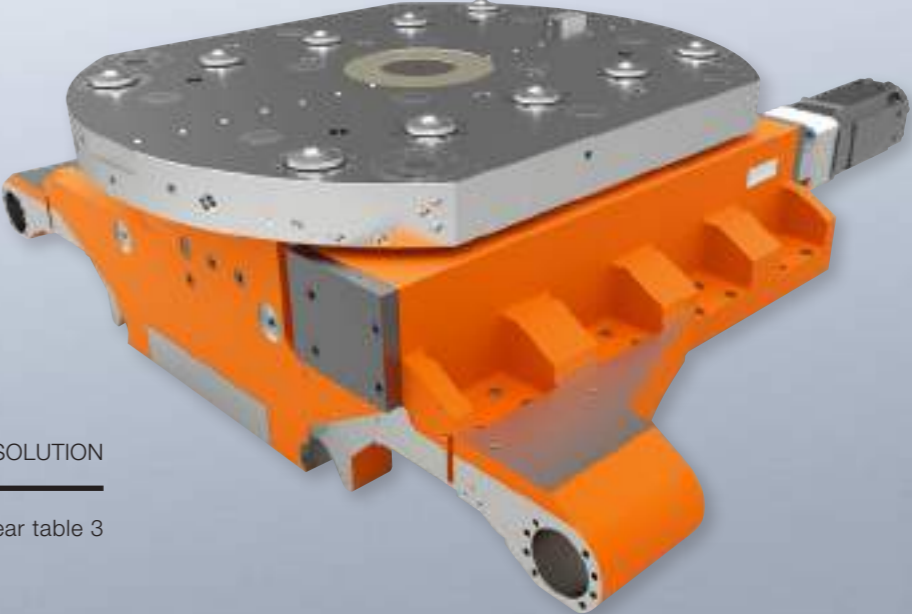



# SPECIAL SOLUTIONS FURTHER COMBINATIONS

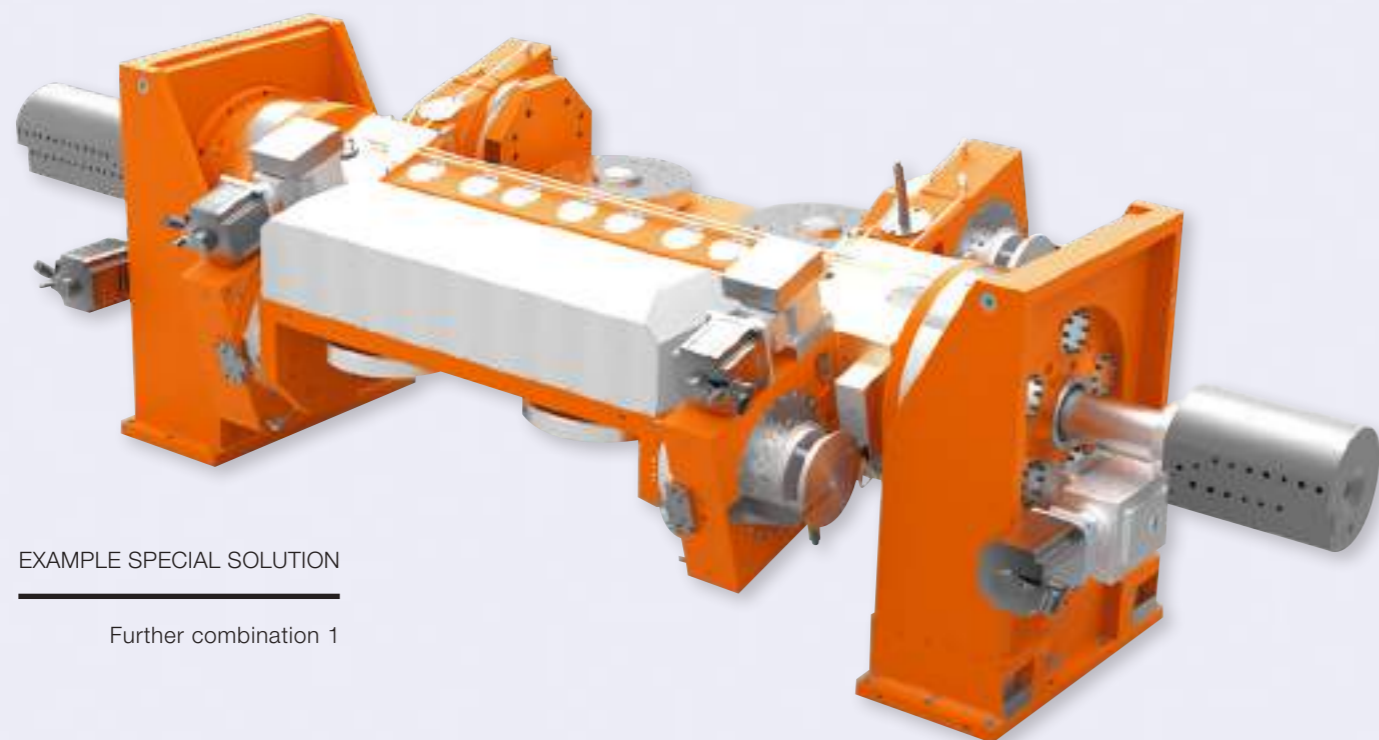

EXAMPLE SPECIAL SOLUTION

Further combination 1



EXAMPLE SPECIAL SOLUTION

Further combination 2

# HOLDING FIXTURES

EXAMPLE

Holding fixture 1

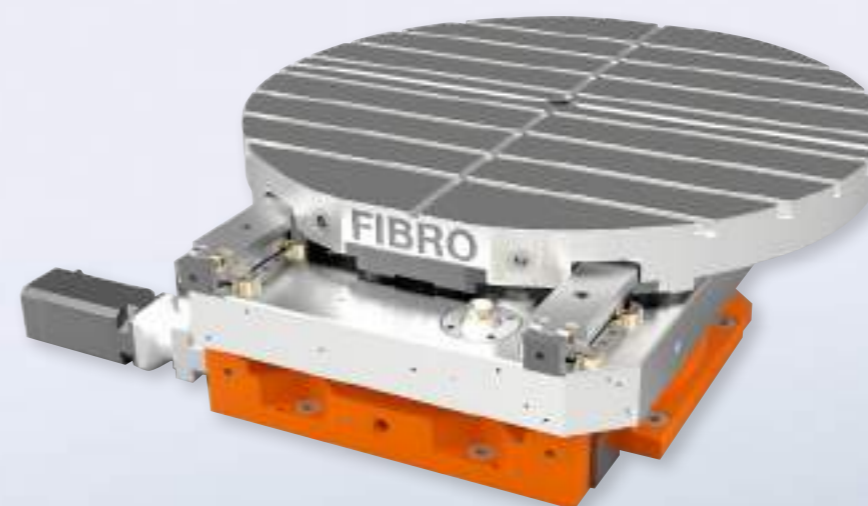
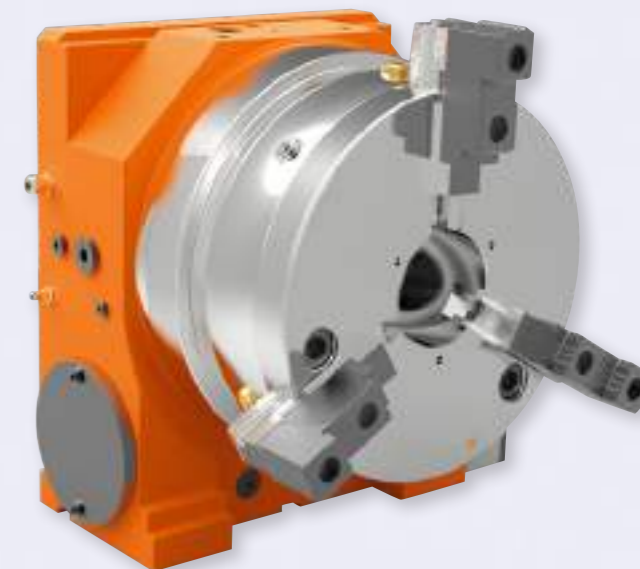

EXAMPLE

Holding fixture 2

EXAMPLE

Holding fixture 3

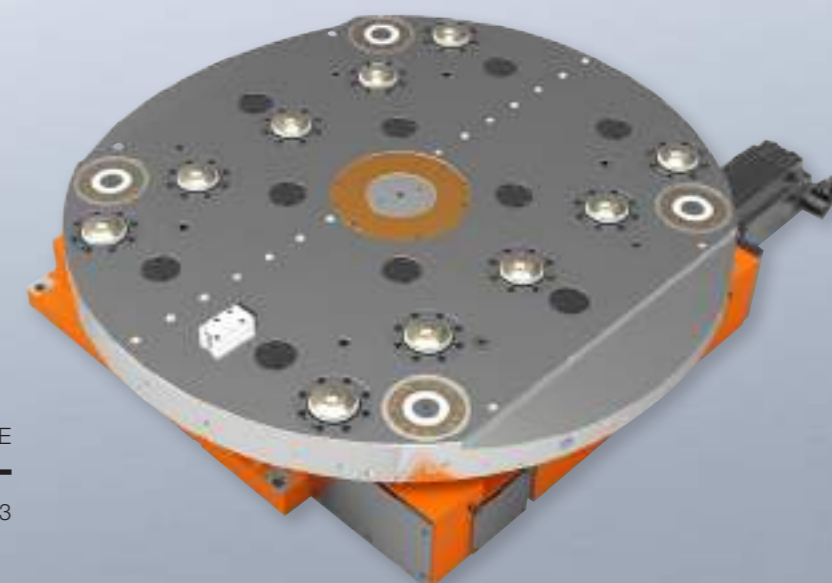

ROOM FOR  
**IDEAS, SKETCHES, NOTES**

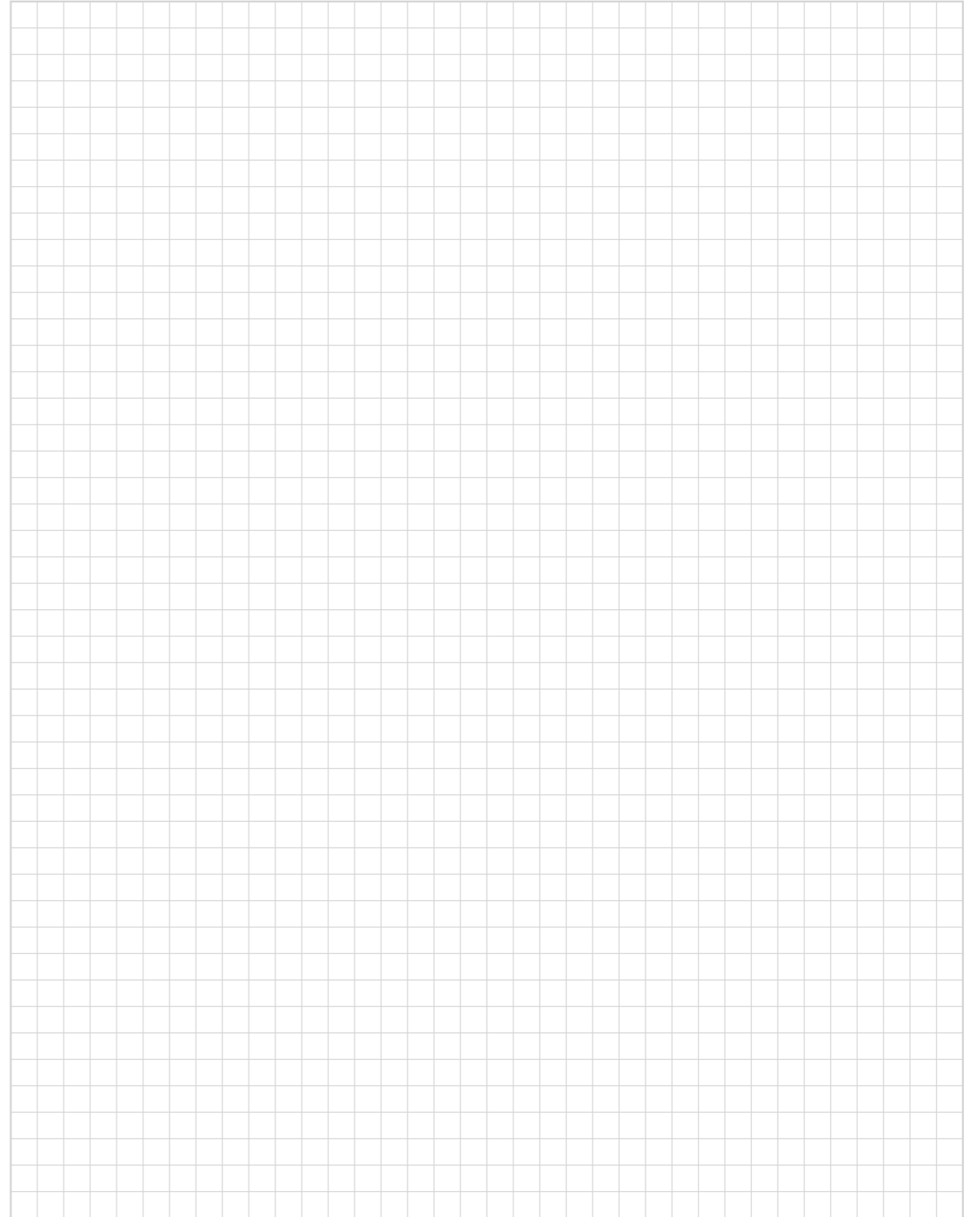
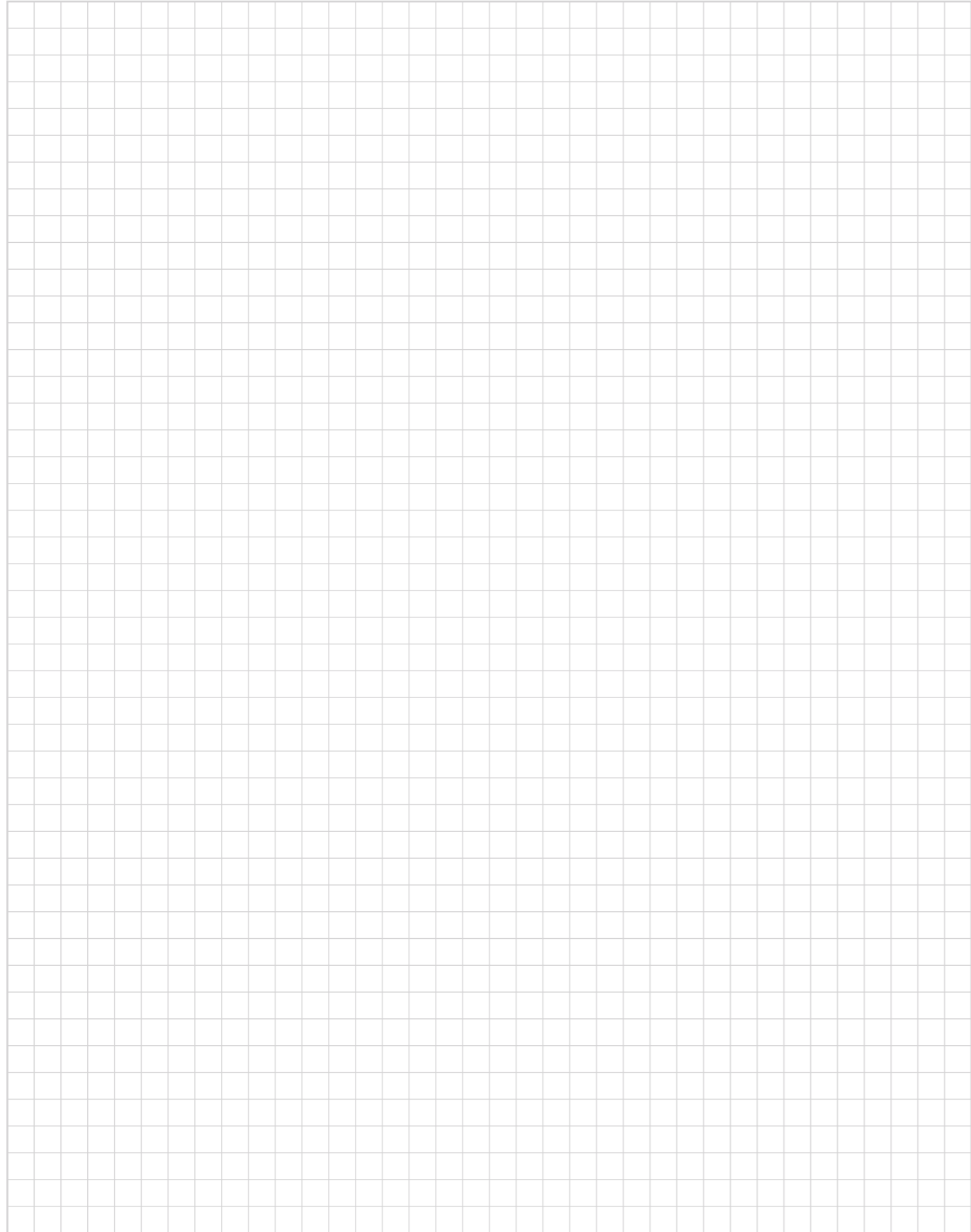

Sales & Distribution in México:  
 Yukme  
 Ignacio Zaragoza #7,  
 Col. Santa Ana Tlapaltitlan  
 Toluca, Edo. de México.  
 Oficinas: Aguascalientes,  
 Saltillo, Puebla, Toluca.  
 T: +52 (722) 217-2236  
 F: +52 (722) 217-2352  
 info@yukme.com.mx  
 www.yukme.com.mx

FIBRO GMBH

Business Area Rotary Tables  
 Weidachstraße 41-43  
 74189 Weinsberg  
 GERMANY  
 T +49 7134 73-0  
 info@fibro.de  
 www.fibro.com

**LÄPPLE AUTOMOTIVE**  
**FIBRO**  
**FIBRO LÄPPLE TECHNOLOGY**  
**LÄPPLE AUS- UND WEITERBILDUNG**

#### BRANCH OFFICES

##### **FIBRO FRANCE SARL**

26 Avenue de l'Europe  
 67300 Schiltigheim  
 FRANCE  
 T +33 390 204040  
 info@fibro.fr  
 www.fibro.com

##### **FIBRO INC.**

139 Harrison Avenue  
 Rockford, IL 61104  
 USA  
 T +1 815 2291300  
 info@fibroinc.com  
 www.fibro.com

##### **FIBRO INDIA**

##### **PRECISION PRODUCTS PVT. LTD.**

Plot No: A-55, Phase II, Chakan Midc,  
 Taluka Khed, Pune - 410 501  
 INDIA  
 T +91 2135 33 88 00  
 info@fibro-india.com  
 www.fibro.com

##### **FIBRO**

##### **PRECISION PRODUCTS CO., LTD.**

1st Floor, Building 3, No. 253, Ai Du Road  
 Pilot Free Trade Zone, Shanghai 200131  
 CHINA  
 T +86 21 60 83 15 96  
 info@fibro.cn  
 www.fibro.com

##### **FIBRO ASIA PTE. LTD.**

9 Changi South Street 3, #07-04  
 Singapore 486361  
 SINGAPORE  
 T +65 65 439963  
 info@fibro-asia.com  
 www.fibro.com

1.3002.01000.01 As of: 09/2018

